



THE CLARENDON Enterprise

THE CLARENDON NEWS & THE DONLEY COUNTY LEADER

CAR-RT LOT**B 006 EXPIRES 5/15
CLARENDON SCHOOL LIBRARY
PO BOX 610
CLARENDON TX 79226-0610

08.14.2014

The Texas Panhandle's First Newspaper
Established 1878.

www.ClarendonLive.com

Single Copy \$1.00

THIS WEEK

- 2 Fred says a recent addition to the Courthouse Square is a 'monumental mystery.'
- 3 Beef producers can apply for disaster aid.
- 4 Bob warns of scams in the wake of damage caused by storms.
- 5 The Broncos get ready to scrimmage Bovina here this week.

All this and much more as *The Enterprise* reports in this week's amazing edition!

Prairie chicken to be conference focus

A Lubbock conference will give landowners tools and strategies for Lesser Prairie Chicken recovery next month.

The forum will be held September 11 at the National Ranching Heritage Center, 3121 4th Street, and is co-hosted by Ranching Heritage Center and the Texas Agricultural Land Trust.

Attendees may receive 2.0 hours of CLE credit awarded by the State Bar of Texas.

Those interested can check the following website for forthcoming details: www.tx-landtrust.org.

CISD accepts tech grant proposal

The Clarendon Consolidated Independent School District Board of Trustees held a called meeting August 5 with a short agenda.

A review of the Technology Integration Grant, Year II, was given to the board by Superintendent Monty Hysinger. Trustees voted to accept the Technology Integration Grant, Year II, proposal as presented.

The board also approved the purchases of Instructional Tools from Pro Computing Corp for 42 Promethean Boards and for a plasma cutter from Dynatorch, as per grant guidelines.

Trustees will meet August 26 to discuss the district's budget and tax rate for fiscal year 2015. The public's participation in that meeting is encouraged.

Methodist Church to host Hearn, Glunt

Memphis High School senior running back Kenbriel Hearn missed his entire senior year due to a stroke at the beginning of the season, but now he says God is opening doors for him and his story.

Hearn, who is now a student at West Texas A&M University, will bring his message to Clarendon's First United Methodist Church on Sunday, August 24, at 6 p.m.

Also appearing August 24 will be Jim Glunt, an evangelist singer-songwriter who has spent his lifetime touring and recording with many country and gospel groups.

Glunt, a four-time recipient of the Country Gospel Music Association's Western Region Producer of the Year award, and he's bringing his mixture of original music, contemporary worship, classic gospel, and timeless hymns, along with his powerful testimony.

Youth from all local churches and Clarendon College are invited to attend.

Shot clinic planned

The Texas Department of State Health Services will hold Immunization Clinics in Clarendon August 14, and 21 from 8:30 to 11:30 a.m. and from 1:00 to 3:30 p.m. at the TDSHS office at Five Medical Drive with the first 15 clients being seen.



Top Photo: The property of Melodean Mitchell shows the full force of Saturday's storm with the remains of the home's roof strewn about the area. Bottom Left: A fallen carport pins the vehicles of Billy and Lois Woods, while a nearby tree (bottom middle) was snapped off near the ground. Bottom Right: Bent and twisted metal shows the force of the storm at the old Canteen building.

ENTERPRISE PHOTO / ROGER ESTLACK

Storm hammers Howardwick

By Roger Estlack, Clarendon Enterprise

Howardwick residents were battered by high winds Saturday evening, August 9, resulting in thousands of dollars in property damage.

No human injuries have been reported. Trees in the community took the biggest toll with some limbs and trunks of approximately ten-inch diameters being snapped, although many were already weakened due to persistent drought and disease.

Howardwick Fire Chief Joe Hall said he estimated the Clarendon Country Club golf course alone sustained \$8,000 to \$10,000 in damage to trees.

The storm hit about 6:30 p.m. and knocked out power with winds reaching sustained speeds of more

than 75 miles per hour, and Hall said a microburst may have accompanied the storm. City officials said much of the damage was along Haskell Street between Columbia and Pampa streets.

Two mobile homes were destroyed near Haskell and Columbia, and the residence of Billy and Lois Woods suffered heavy damage at the corner Haskell and Pampa. A the couple's wood structure carport was collapsed onto their vehicles, and their two-car carport that covered their boat and was anchored in concrete was ripped from its location and came to rest in a nearby field about a quarter of a mile away. Mayor Mike Rowland said he found a washtub-sized piece of concrete from that carport in his field.

The Woods also lost their covered

porch, which was folded back over onto their roof, causing significant damage to their home.

Heavy damage also struck on Frederick Street near Columbia where the roof was torn off the home of Melodean Mitchell, causing damage to a nearby carport. Some of the debris was dropped on a nearby RV while the remainder was scattered several yards from the property.

Hall was in a fire truck near City Hall and watch the storm peel the roof up on the old Canteen store and saw the sign at the Howardwick Baptist Church blow away.

"I couldn't see the front of my fire truck for about five minutes" due to the rain, Hall said.

The storm also downed tree limbs and twisted swings at the city

park. "I'm very grateful no one was hurt," Hall said. "And I'm proud of the way our firefighters handled their jobs."

Hall thanked the Clarendon Volunteer Fire Department, the Donley County Sheriff's Office, and the Associated Ambulance Authority for their assistance during and following the storm. He also said his department is in need of donations, and more information can be obtained at City Hall.

Officials also urge citizens to be wary when hiring contractors to clean up storm damage. Hall says property owners need to make sure their contractors are insured, and Enterprise columnist Bob Watson has more advice on this subject in this week's issue.

Luncheon to focus on area elected women

The 5th Annual Louise Daniel Women's History Luncheon and Women's Equality Day Celebration will be held at 11:30 a.m. Friday, August 22, 2014, in the Great Hall of Polk Street United Methodist Church, 1401 S. Polk in Amarillo.

The occasion will honor women elected officials, past and present, of the Texas Panhandle. The luncheon is held annually near the end of August to coincide with Women's Equality Day, which commemorates the ratification of the 19th Amendment to the U.S. Constitution giving women the right to vote.

Several current and former elected women from Donley County are included on the organization's

records. The earliest ones they have a record of all served as Donley County clerk: Lottie E. Lane in 1923, Bessie (Mrs. B.G.) Smith, 1929; Helen Wiedman, 1940, and Helen W. Churchman, 1953. Those serving in county positions during the 1980s included Sandra Eads, Freida Gray, Wilma Lindley, Wanda Smith and Alice Fay Vargas.

Many more women have served in local positions through the years. Among the local women serving in county or city positions currently include Gail Leathers of Howardwick; Carrie Butler, Kathy Spier and Tonya Metcalf, all of Hedley; and Denise Bertrand, Beverly Burrow, Linda Crump, and Connie Havens, all of Clarendon.

Guest speaker at the day will be Nancy Baker Jones, Ph.D., of Austin, on the topic "Winning the Vote and Voting to Win: Texas Women and Politics." Dr. Jones is president of the Ruth Winegarten Foundation for Texas Women's History and General Editor for the Women in Texas History Series of the Texas A&M University Press.

Baker and Winegarten wrote Capitol Women: Texas Female Legislators 1923-1999, published by the University of Texas Press and winner of the Liz Carpenter Award from the Texas State Historical Association. The two also wrote the script for the 7th grade video, From Gutsy Mavericks to Quiet Heroes: True Tales of Texas Women

produced by the Foundation for Women's Resources.

Dr. Paul Matney, retiring president of Amarillo College, will make a special presentation regarding the naming of a room at the college in honor of Louise Daniel, who had been a member and chairwoman of the AC Board of Regents.

The public is invited to attend. The cost is \$25 for adults, \$15 for students, and \$200 for a table of eight. Reservations should be made by Monday, August 18, by calling Jane Harlan at (806) 355-4125 or sending a check to the Amarillo College Foundation in care of Harlan at 4015 S. Lipscomb, Amarillo, TX 79110, noting that it's for the Louise Daniel luncheon.



New adventures!

Incoming kindergartener Kinslee Hatley and her mom, Sarah, smile as they fill out paperwork at Clarendon ISD registration Monday night. Registration continued Tuesday and Wednesday. Classes at both Clarendon at Hedley schools will begin Monday, August 25. All your back-to-school information including calendars and schedules can be found on our website at www.ClarendonLive.com. Enterprise Photo / Roger Estlack

City sales taxes drop in August

2014 tally second best in five years

By Roger Estlack, Clarendon Enterprise

Clarendon's sales tax receipts are down for the fifth straight month, but the city is still showing its second highest returns in the last five years.

Texas Comptroller Susan Combs reported August sales tax allocations last Wednesday and showed Clarendon as being down 15.12 percent for the month at \$37,353.16 compared to \$44,009.31 last year.

Local sales in 2013, however, were bolstered by temporary workers living here as part of a pipeline crew, with some months reporting sales tax receipts greater than 40 percent above similar periods in 2012.

Compared to 2012, this month's city sales tax revenue is up 4.92 percent. And while the city's year-to-date figure is currently down 5.50 percent at \$261,007.49, the total for the year thus far is 19.1 percent ahead of the same point two years ago.

August year-to-date sales tax totals for the city over the last five years are as follows: 2014 - \$261,007.49; 2013 - \$276,214.96; 2012 - \$219,134.53; 2011 - \$225,853.82; and 2010 - \$207,357.53.

Also in Donley County, Howardwick saw its monthly figures drop 40.31 percent to \$1,069.09, and that city's year-to-date total is down 21.11 percent at \$11,244.80. Hedley, however, shows some modest growth with a monthly figure up 9.61 percent at \$982.32 and a year-to-date total up 3.03 percent at \$5,115.17.

The sales tax figures represent monthly sales made in June as well as April, May and June sales by businesses that report tax quarterly, all of which were reported to the state in July.

Statewide Combs said that state sales tax revenue in July was \$2.34 billion, up 6.3 percent compared to July 2013.

"The growth in sales tax revenues reflected strength in both business and consumer spending," Combs said. "The increase was led by remittances from the construction, services, and oil and natural gas-related sectors, as well as from retail trade and restaurants."

"Fiscal year-to-date, state sales tax collections are now up 5.3 percent."

Grand Jury delivers five indictments

The Donley County Grand Jury handed up five indictments against four individuals during its August 6 session, according to information from District Attorney Luke Inman's office.

Gary Dale English was indicted on a Class A Theft in a case that will be filed in county court for an offense committed on May 17.

Paul Alexander Rodgers was indicted on a second degree Aggravated Assault with a Deadly Weapon charge for an offense committed on May 9.

Frank Wesley Carson was indicted on a second degree Aggravated Assault with a Deadly Weapon charge and a third degree Assault on a Family Member charged for offenses committed May 18.

Carson was also indicted on five counts of third degree Retaliation for offenses committed May 18.

Victor Antonio Mendoza was indicted for Driving While Intoxicated, a third degree charge enhanced to second degree, for an offense committed May 10.

We are too busy, even on a Sunday

Masses of folks are in lockstep, completing daily routines with heightened speed, too often in fast-forward mode. Mostly, it is left to seniors to amble along, their lives ratcheted down by bodies unable to keep pace and/or people who take life in smaller bites.

Some learn – usually “later than sooner” – that “rose-smelling” along the way is an admonition that, once attempted, results in repeated yearnings to inhale life’s best fragrances.

Our world is a noisy one, too. Hundreds of millions cry out. Some are never heard, and many pleas are muffled at their beginnings. Prevailing is the feeling we’ve “seen this show before” – or heard it – or am I addressing only myself?



the idle american
by don Neubury

A vignette, please. My wife and I mapped out a recent Sunday morning trip. Plenty of time was allowed for the leisurely 70-mile jaunt across the Metroplex. We wanted to hear Dr. Richard Jackson, a lifelong friend who was to preach three sermons on his 76th birthday.

Shortly before our arrival at the church for his third volley, we stopped at McDonald’s. (I’m never worried if I miss the freeway exit – there always are others just ahead.)

We stop there for three reasons – the second for McDonald’s almost always good, fresh coffee, and the third, the discounted price for senior adults....

Inside was a cross-section of life. I was the only tie-wearer, and a goodly number – dressed casually and less – seemed bent, however painfully, on jump-starting their day after a short night.

A woman, neatly dressed, approached me. Her face was not familiar, but her request was.

“Do you have two dollar bills?” she asked. I felt the hovering of providence, recalling an \$8 purchase the night before that resulted in exact change – \$2. The two bills, folded around charge cards, prevented my being flat broke....

Thoughts raced. I resisted the urge to lecture her. “Has inflation moved into panhandling, too?” I pondered. I recalled dozens of other similar requests along the way, usually in teeming cities. Typically, though, requests were for extra change, or maybe a dollar. But she wanted two.

I smiled, asking her why she needed the two dollars.

She smiled back, reaching into her purse, “Because I’m in line at the car wash. The machine takes only ones, and all I’ve got are 20s and this two-dollar bill.” We traded currency; I shoved the crumpled \$2 bill into my pocket. My wife reappeared, and I steered our conversation to the dangers of pre-judging as we proceeded to church....

We heard about God’s love from a powerful preacher whose every word seemed heaven-sent.

At lunch, with him, his wife Wanda and friends Mickey and Linda Eddins, we spoke of many things.

Richard was asked if he’d ever suffered from “tangled-tongue” in the pulpit. “All preachers have,” he answered. “In fact, not long ago my face was self-reddened as badly as yours was today at McDonald’s.”...

Completing his tenure of several months as an interim pastor, he was ready for his final sermon; it was a Sunday night. “But it’s not over ‘until the fat lady sings,’” he joked. The congregation responded not with laughter, but squirmed in something of a nervous titter.

He hadn’t looked far enough down the worship guide. A woman he said to be “as fine a vocalist as ever sang a note” indeed was scheduled to sing. His face already crimson, he glanced toward the choir, his eyes locking with those of the featured vocalist – a woman he said was “considerably to the left of portly.” When she took the microphone, she had a one-sentence sermon for him before breaking into song. “And I’m going to sing this special with every ounce and every pound of my being.”...

Dr. Jackson spoke in a hushed tone of his late father, also a fiery preacher. His dad, ever the mentor to his young preacher son, advised him in construction terms. “Son, if you’ll keep your mortar thick, you won’t have to throw it near as hard to make it stick.” It was a good day.

Jackson, still “in the spirit” at 76, preached with “thick mortar.” Lunch, unhurried, was great. Three couples’ remembrances of 160 years of marriage brought smiles, and Eddins paid the check....

Dr. Neubury is a speaker in the Dallas/Fort Worth Metroplex.

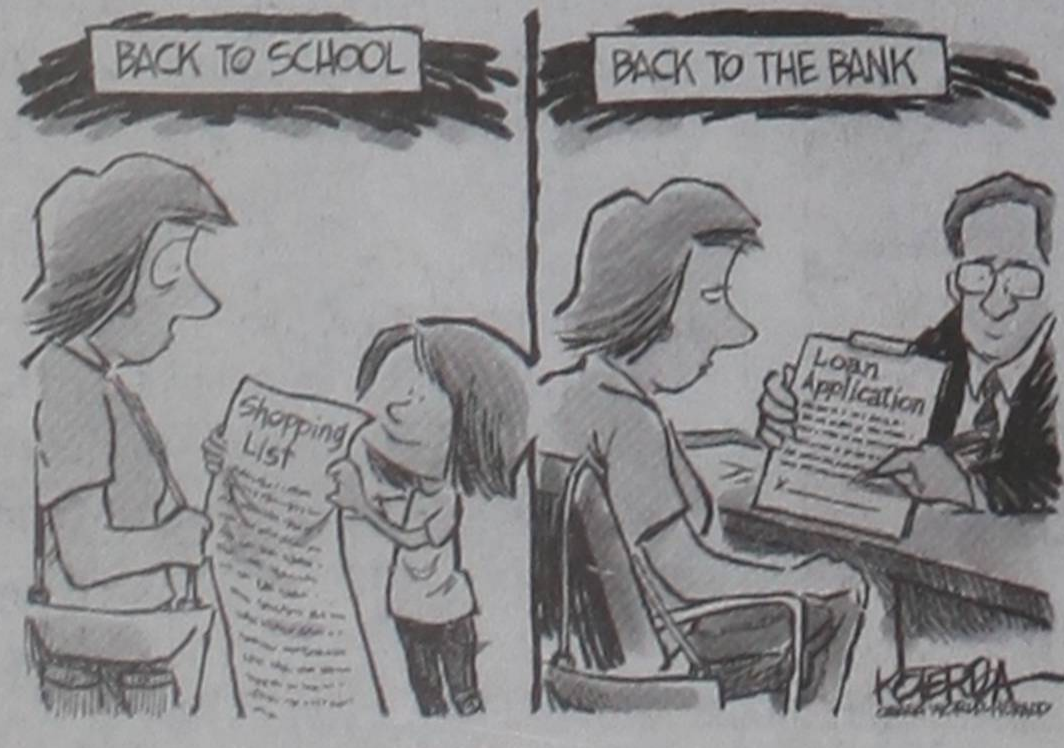

A monumental mystery on the square

As you all may well know, a monument suddenly appeared in front of the Donley County Courthouse Annex a couple of weeks ago. Most folks knew it was coming, so it’s not a great surprise. On it, many statements were attributed to several Founding Fathers, along with others, including the Ten Commandments. Anyway, with all the engraving that was done on the monument I wonder if it is, in effect, a graven image? Just kidding – well, sort of.

Even though the monument is a weighty thing, I wonder what the point of it is. What is its purpose? What are the people behind the monument trying to say? For example, the monument includes statements attributed to George Washington, James Madison, John Jay, and alas, Patrick Henry, among others. Why, “alas” Patrick Henry? Because the monument uses a bogus quote attributed to Patrick Henry, in a 1956 magazine article. The quote is as follows, “It cannot be emphasized too strongly or too often that this great nation was founded, not by religionists, but by Christians; not on religions, but on the gospel of Jesus Christ!”

Several respectable sources dispute that Patrick Henry actually wrote or said this. Unfortunately, according to the Huffington Post, “the quotation still appears regularly in Facebook and Twitter posts, and, remarkably, in presidential aspirant Newt Gingrich’s 2011 book, *A Nation Like No Other* (p. 76). And this from the only candidate with a history Ph.D.!”

“It is what it is, a totally inaccurate statement,” according to my publisher Roger Estlack. It is puzzling as to why the quotes on the monument were not properly vetted. Actually, it is highly

embarrassing that a false quote is now forever memorialized in front of the Courthouse Annex. We may have a possible \$20,000 “oops” setting in our front yard.

There is also a misspelling or misuse of a word included in the history of Clarendon at the back of the monument. The history reads, “...purchased large tracks of land...” Actually, it should read, “... purchased large tracts of land...” Of course, they could have been referring to dinosaur, train, or animal tracks that can be found in the neighborhood. The monument also mistakenly uses the word “purposed” instead of “proposed.”

Finally, I get the feeling that the people who placed this monument may have intended it to suggest that our nation was founded on Christian values. If so, nothing could be farther from the truth. While many of the Founding Fathers were Christians, the Constitution and structure of the country were based strictly upon Enlightenment principles.

Most Americans seem to be under the erroneous idea that the Founding Fathers were pious, prayerful men. That is not the case. They were skeptical men of the Enlightenment who questioned each and every idea that they were taught. They were very well read in political philosophy and science, and were well versed in theological matters. They continually challenged the religious teachings they heard, both publicly



the quick, the dead, & fred
by fred gray

and privately.

For example, Thomas Jefferson counseled his nephew to subject the authors of the New Testament to the same textual scrutiny he would give to other ancient historians like Tacitus or Livy, and to treat the supposed biblical miracles with suspicion. Jefferson himself edited a version of the New Testament that left out every miraculous and supernatural event, leaving only Jesus’ moral teachings.

George Washington, on the other hand, rewrote the presidential addresses crafted for him by his speechwriters so as to omit all references to Jesus Christ. And James Madison, who was quoted on the monument, gave his opinion that, “Religious bondage shackles and debilitates the mind and unfits it for every noble enterprise, every expanded subject.”

The era of the Founding Fathers was not an age of faith but an age of science and skepticism, and the Founding Fathers were in the lead. The American Revolution, and the subsequent founding of the United States of America, embodied the Enlightenment values that had been formulated over the previous hundred years or so. Our American experiment was originally an Enlightenment experiment.

I think the monument would be better placed in front of a church or even on private property. It has no place in front of our magnificent courthouse, a true monument to local government, and a temple of justice. I agree with Jefferson and the Founding Fathers that there must always be a wall separating church and state. The mystery monument is located in the wrong place, for the wrong reasons.

Suggested memorials for the Donley County Courthouse



Clarendon school is the best around

This is in response to the Editor’s Commentary a couple of weeks ago in The Clarendon Enterprise regarding school days and how they have changed. I would like to acknowledge that the editor is right and things have changed, some for the better, some for the worse. Our world is not the same. Our school and the newspaper is not the same as they were in 70s either, and I doubt either one wants to go back to the “old ways” of business.

In my opinion, when we talk about our school or school in general as parents, grandparents, and educators, it’s our duty to accentuate the positive. I think it’s safe to say that our kids’ opinions about school, teachers, rules, the AR program, homework, etc., are formed from hearing our opinions verbalized. Just because we as adults might not agree with every detail at the school doesn’t mean we should discuss it in a manner where the kids could take it as, “Hey, my parents are upset with the school,” when it’s usually just what I call “innocent griping,” which we all do. And I’m not implying in any way that you, Roger, would ever mention that the AR program at school was “stupid” in front of your kids. I’m just saying that even when we don’t happen to verbalize that we have a problem with something, our kids pick up on our tone, body language, etc. And if anyone reading this is going to be a parent of a first grader this school year, take note: it is “not required” for your child to take a book home at night for AR. Their reading and testing are done during the school day.

No, our school is not perfect. No school is. But the positive far outweighs the negative at Clarendon CISD. I believe we have a wonderful school system, and there are great things going on at every level. I just happen to know more about what all they do in my granddaughter’s class. There is a lot of paperwork going, but the students do still have to learn to add, subtract, write, and spell, etc. And as in the 70s, I believe that the best way, still today, is by repetition and on paper. But there were so many wonderful experiences

for our children last year. They put on a puppet show, cooked Green Eggs and Ham, hatched baby chicks, cared for a baby tarantula, observed various spiders in their classrooms, and made apple pies and popcorn balls all in conjunction with a classroom lesson on various subjects. The kids also presented a great Veterans Day program. Plus so much more.

Another positive at our school is technology. I think Clarendon CISD is doing a great job preparing our kids in this area. Anyone who would like to take a closer look at what our school has to offer in this area I’m sure they’d love to show it off. I think the teachers, administrators, and support staff our school has are, hands down, better than any school around and the quality of education is top notch. So before anyone complains about buying school supplies or not being provided free pre-Kindergarten, neither of which the school is required to do, go check out what kind of programs, teachers, and facilities your children do have here, and then feel free to tell anyone that will listen how good we’ve got it!

Now, if you had some great teachers at Clarendon CISD, like I did, please feel free to tell them you appreciated them, such as Sam Lowry, Jean Stavenhagen, Helen Land, Coach Jack Hall, Johnny Leathers, Bob Howell, Carrie Howell, Jeff Walker, Kay Hayes, Bobbie Thornberry, and many more.

René Mott, Clarendon

A modest proposal...

A sure sign that the rapture is near is when I find some occasional common ground with Fabulous Fred. More likely is that I am losing my rather tenuous grip on sanity. In his Killer Weed commentary I found some spotty agreement which is generally cause for rethinking my position. In discussions of drugs, I paint with a broad brush by including alcohol and nicotine in the genre.

I believe it is true that casual and infrequent use of marijuana is not a significant health risk for the two people in the world that are causal and infrequent users. The problem is that none of my

junkie friends ever saved anything for later and smoke all they could get their hands on as quickly as they could. So the casual user concept is moot, and there are a fair number of lung and other health issues as well as societal problems associated with chronic use. They will spend every cent they can earn, beg, borrow, or steal on the drug to the exclusion of bathing, shaving, washing clothes, rent, or dental bills, which suggests it is not an innocuous recreational drug. In truth, there are no innocuous drugs.

Prohibition should have shown us what happens when Congress creates a situation where really bad people get really rich and powerful (comments on Congress will come at a later date). I do not think that there are any easy solutions to our drug use. The current system of largely unsuccessful attempts at interdiction have created a situation where the profits of transport and delivery of drugs are so large that there are ten people fighting to take the place of every one that was caught. Only Kamikaze pilots and suicide bombers are harder to control.

I do want to suggest a simple idea for changing the status quo. Simple does not mean easy, just uncomplicated. We, as a nation, should put the problems associated with using drugs back on the user. Receiving public assistance at any level will require passing random and frequent drug tests. Not just for Mom, but for the whole family. One fails and they all fail. Hopefully a good buzz will not be worth being cold, hungry, and living under a bridge. Junkies are always getting hurt and are the trial bars’ best repeat customers. So if you get drunk, drive, and hit a tree, you can no longer blame the tree or its owner. Prove up clean and sober at the hospital or “Torts ‘R’ Us” is out of luck. Plus, ERs will no longer be forced to give free care to overloaded junkies. Too harsh? What we are doing now is not working and the floor is open for suggestions because there is a problem and it is not going to cure itself.

Richard Sheppard, DDS, Clarendon

137th Year, Series 3, Vol. XXV, No. 23 • E19.20
The Clarendon Enterprise (USPS 947040, ISSN 1088-9698) is published each Thursday by Roger A. Estlack at 105 S. Kearney Street, Clarendon, Texas 79226-1110. Periodicals postage paid at Clarendon, Texas 79226-1110. Copyright © 2014. All rights reserved.

This paper’s first duty is to print all the news that is fit to print, honestly and fairly to all, unbiased by any consideration even its own editorial opinion.

Any erroneous reflection upon the character, standing, or reputation of any person, firm, or corporation which may occur in the columns of The Clarendon Enterprise will be gladly corrected upon being brought to the attention of the management.

ENTERPRISE STAFF

Roger A. Estlack
Publisher & Editor

Ashlee Estlack
Contributing Editor

Tara Hogan
Office Director

Morgan Wheatly
Ads & Layouts

CORRESPONDENTS

Peggy Cockerham
Howardwick

Sandy Anderberg
Clarendon Sports

Fred Gray
College & Hedley Sports

Karl Lindsey
Photographer

Matthew Martinez
Photographer

Kathy Spier
Hedley

CONTACT INFORMATION

Phone
806.874.2259

Fax
806.874.2423

E-Mail
news@clarendononline.com

Web Site
www.ClarendonLive.com

ADVERTISING

Open Display rates are \$5 per PASS column inch. Classified Ads are \$10 for the first 15 words and 15¢ per word for each additional word (Boxes or special typography are extra.). Thank You Notes are \$15 for the first 40 words and 15¢ per word for each additional word. Basic engagement, wedding, anniversary, and birth announcements are \$10 each. Expanded wedding announcements are \$20. A one-column announcement picture is \$5, and a two-column announcement picture is \$10. Pictures submitted for publication should be picked up within ten days after publication. Death notices are printed at no charge. Obituaries are published for \$45 or \$50 with a photo.

DEADLINES

News articles and photos are due by Monday at noon. Advertising and Classifieds are due by five o’clock Monday afternoon. Deadlines may be altered for holidays or special issues.

SUBSCRIPTIONS

Annual subscriptions are available for \$30 for zip codes inside Donley County, \$40 elsewhere in Texas, and \$45 out of state. **POSTMASTER:** Send all address changes to: The Clarendon Enterprise, PO Box 1110, Clarendon, TX 79226-1110. **Digital Subscriptions** are \$15 per year.

LETTERS

Letters to the editor are welcome. Views expressed in letters are those of the writers and do not necessarily reflect the views of the editor or staff of The Clarendon Enterprise. Submission of a letter does not guarantee publication. Letters may be edited for grammar, style, or length. All letters must be signed and must include an address and telephone number for verification. To improve your chances of publication, type and double space your letter, stick to one main topic, and keep it brief. No letters will be accepted from candidates for local political offices. Letters submitted to this newspaper become the property of The Enterprise and cannot be returned.

The Texas Panhandle’s First Newspaper

The CLARENDON NEWS, established June 1, 1878 with which have merged: The Clarendon Traveler, February 1889; The Clarendon Journal, November 1891; The Banner-Stockman, October 1893; The Agitator, February 1899; The Clarendon Times, May 1908; The Donley County Leader, March 12, 1929; The Clarendon Press, May 18, 1972; and The Clarendon Enterprise, March 14, 1996.

Member 2014



National Newspaper Association



Texas Press Association



West Texas Press Association



Panhandle Press Association



Texas beef producers can apply for disaster aid due to drought

COLLEGE STATION – Federal disaster aid for Texas cattle producers is available and officials are encouraging producers to act quickly in applying for programs.

U.S. Department of Agriculture-Farm Service Agency Texas administrators gave updates on livestock disaster programming in College Station at the 60th Texas A&M Beef Cattle Short Course, coordinated by the Texas A&M AgriLife Extension Service and the department of animal science at Texas A&M University.

Ranchers are encouraged to call the Farm Service Agency office in their county to set up appointments as deadlines approach for these programs, officials said.

The disaster programs are part of the Agricultural Act of 2014, the new farm bill, which will help Texas cattle producers rebuild and recover drought losses dating back to 2011, said Judith Canales, Texas state executive director for the USDA-

Farm Service Agency. “(As of Aug. 6), \$258 million in livestock disaster payments have been distributed in Texas,” Canales said. “We have 173 offices here in Texas to work with you, and we encourage you to schedule an appointment.”

Highlights of programs offered to cattle producers were:

- Noninsured Crop Disaster Assistance provides assistance to producers of non-insurable crops when low yields, loss of inventory or prevented planting occur due to a natural disaster. This includes grasses planted for livestock production. A fact sheet on this program is available at www.fsa.usda.gov/nap.

- The Livestock Indemnity Program provides benefits to livestock producers for livestock deaths in excess of normal mortality caused by adverse weather. To be eligible, a producer must have legally owned the eligible livestock on the day the livestock died. A fact sheet on this

program is available at <http://1.usa.gov/1sIsUaj>.

- The Livestock Forage Disaster Program is retroactive to cover eligible livestock producers who have suffered grazing losses for covered livestock on land that is native or improved pastureland with permanent vegetative cover or is planted specifically for grazing. The program provides compensation to eligible livestock producers who have suffered grazing losses on rangeland managed by a federal agency if the producer is prohibited by the federal agency from grazing normal permitted livestock on the managed rangeland due to a qualifying fire. The grazing losses must have occurred on or after Oct. 1, 2011. Payments are based on animal units. A fact sheet on this program is available at <http://1.usa.gov/1sAsEWe>.

For more information on the disaster programs, visit <http://1.usa.gov/1sFKON6> or contact a local Texas FSA county office.

Cotton transition enrollment begins next week

WASHINGTON – U.S. Department of Agriculture (USDA) Farm Service Agency Administrator Juan M. Garcia today announced that farmers can enroll in the Cotton Transition Assistance Program (CTAP) from Aug. 11, 2014 through Oct. 7, 2014.

The program, created by the 2014 Farm Bill, provides interim payments to cotton producers during the 2014 crop year until the Stacked Income Protection Plan, a new insurance product also created by the legislation, is available. Details on the plan will be released by mid-August.

“The Cotton Transition Assistance Program is another milestone in USDA’s ambitious timeline for implementing the provisions of the 2014 Farm Bill. Cotton producers now have a risk management tool in

place,” said Garcia. “To help us provide the best service possible, cotton producers are encouraged to schedule an appointment with their local Farm Service Agency office early in this enrollment period,” added Garcia.

CTAP applications approved before Oct. 1, are subject to congressionally mandated automatic reductions of 7.2 percent for the 2014 crop year. Applications approved after Oct. 1 will be reduced the required 7.3 percent for the 2015 crop year. The Budget Control Act of 2011 requires USDA to implement these reductions to program payments.

CTAP and the Stacked Income Protection Plan were established by the 2014 Farm Bill. The Farm Bill builds on historic economic gains in rural America over the past five

years, while achieving meaningful reform and billions of dollars in savings for taxpayers. Since enactment, USDA has made significant progress to implement each provision of this critical legislation, including providing disaster relief to farmers and ranchers; strengthening risk management tools; expanding access to rural credit; funding critical research; establishing innovative public-private conservation partnerships; developing new markets for rural-made products; and investing in infrastructure, housing and community facilities to help improve quality of life in rural America. For more information, visit www.usda.gov/farmbill.

For more information about CTAP, visit a local FSA office or go online to www.fsa.usda.gov.

NOTICE OF PUBLIC MEETING TO DISCUSS BUDGET AND PROPOSED TAX RATE

The Clarendon Consolidated Independent School District will hold a public meeting at 7:00 PM on August 26, 2014 in the Clarendon CISD Administration and Technology Building located at 416 South Allen Street Clarendon, Texas.

The purpose of this meeting is to discuss the school district’s budget that will determine the tax rate that will be adopted. Public participation in the discussion is invited.

The tax rate that is ultimately adopted at this meeting or at a separate meeting at a later date may not exceed the proposed rate shown below unless the district publishes a revised notice containing the same information and comparisons set out below and holds another public meeting to discuss the revised notice.

Maintenance Tax	\$ <u>1.17</u> /\$100 (Proposed rate for maintenance and operations)
School Debt Service Tax	\$ <u>0</u> /\$100 (proposed rate to pay bonded indebtedness)

Comparison of Proposed Budget with Last Year’s Budget

The applicable percentage increase or decrease (or difference) in the amount budgeted in the preceding fiscal year and the amount budgeted for the fiscal year that begins during the current tax year is indicated for each of the following expenditure categories:

Maintenance and operations	4.84	% increase	or	0	% (decrease)
Debt service	0	% increase	or	0	% (decrease)
Total expenditures	4.84	% increase	or	0	% (decrease)

Total Appraised Value and Total Taxable Value (as calculated under Section 26.04, Tax Code)

	Preceding Tax Year	Current Tax Year
Total appraised value* of all property	\$ 423,371,915	\$ 498,835,488
Total appraised value** of new property**	\$ 78,438	\$ 1,163,947
Total taxable value*** of all property	\$ 142,007,531	\$ 147,893,439
Total taxable value*** of new property**	\$ 78,438	\$ 1,163,947

* “Appraised value” is the amount shown on the appraisal roll and defined by Section 1.04(8), Tax Code.
 ** “New property” is defined by Section 26.01(17), Tax Code.
 *** “Taxable value” is defined by Section 1.04(10), Tax Code.

Bonded Indebtedness

Total amount of outstanding and unpaid bonded indebtedness* \$ 0

* Outstanding principal.

“Everything under one roof!” THE CLARENDON OUTPOST

US 287 WEST • CLARENDON, TEXAS

CALL: 874-5201 • OPEN DAILY 6 A.M. TO 10 P.M. • PHARMACY: 874-5202

AD GOOD THRU: July 21, 2014

OUTPOST PHARMACY
WELLNESS CENTER

Lose Weight with

Garcinia
Cambogia

14-Day Acai
Berry Cleanse



School Supplies at a Reasonable Price!

- Boxes
- Crayons
- Pens
- Pencils
- Colored Pencils
- Scissors
- Rulers
- Folders
- Spirals
- Highlighters
- Dry Erase Makers

College Students

Decorate your dorms with posters, vintage signs, & Fredricksburg Farm Candles

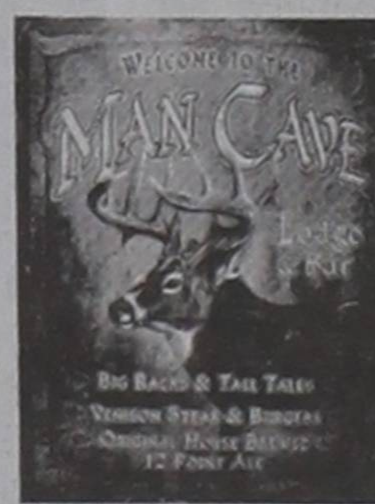

Seasonal • Herbal • Fruit • Food • Floral • Fantasy

Local Artist Western, Wildlife, & Native American Art

Mary Selfridge



OUTPOST DELI
THIS WEEK'S SPECIAL

Coffee MENU

COME IN FOR YOUR COFFEE

- LATTE
- COFFEE
- CAPPUCCINO
- ESPRESSO

★
¿Qué Pasa?
Community Calendar

August 14
Hedley Registration • 8 a.m. to 3:30 p.m.

Girl Scout Recruitment Ice Cream Social • 5-6 p.m. • Dairy Queen

August 15
Broncos v Bovina • Scrimmage • 5 p.m. • Clarendon

Owls v Lefors • Scrimmage • TBD

August 20
Community Kidz Bible Blast • 1:00 to 6:30 p.m. • Community Fellowship Church

August 21
Owls v Kress • Scrimmage • TBD

August 22
Free School Supplies • 1:30 - 3:30 p.m. • Christ's Kids Ministry Center

Broncos v Electra • Scrimmage • 6 p.m. • Electra

August 25
Back To School

August 29
Broncos v Tulia • 7:30 p.m. • Tulia

Owls v Higgins • 7:30 p.m. • Hedley

September 1
Labor Day

September 5
Broncos v S-Earth • Homecoming • 7:30 p.m. • Clarendon

Owls v Lefors • 7:30 p.m. • Lefors

September 7
Grandparents Day

★
Menus

August 18 - 22

Donley County Senior Citizens

Mon: Spaghetti with meat sauce, spinach, garlic toast, salad, fruit bowl, iced tea/2% milk.

Tue: Breaded chicken tenders, baked potato, sour cream, mixed vegetables, strawberry/whip topping, iced tea/2% milk.

Wed: BBQ brisket, ranch style beans, cornbread, carrot sticks, chocolate pudding, iced tea/2% milk.

Thu: Chicken cordon blue, peas & carrots, cucumber salad, wheat roll, cookies, iced tea/2% milk.

Fri: Cheeseburger, lettuce/tomato/pickle, potato wedges, fruit salad, chocolate cake, iced tea/2% milk.

Hedley Senior Citizens

Mon: Sloppy Joes, potato wedges, coleslaw, bake, bun, iced tea/2% milk.

Tue: Pork roast & gravy, black-eye peas, roll, cake, iced tea/2% milk.

Wed: Chicken tenders, garlic mashed potatoes, turnip greens, wheat roll, mandarin oranges, iced tea/2% milk.

Thu: Charbroil beef patty with pepper & onions, garlic mashed potatoes, beets, bread, mandarin oranges, iced tea/2% milk.

Fri: Catfish, corn, coleslaw, hushpuppies, cherry crisp, iced tea/2% milk.

POSITIVE FEED SALES

All-In-One 30% Supplement for Cattle

Brangus Heifers For Sale

DANNY ASKEW

874-5001 or 874-3844

Kenny's Barber Shop and Clarendon Auto Sales
3rd & Jefferson, Clarendon
874-9308
We appreciate your business!

Sandell Drive-In
Paramount Pictures

Transformers: Age of Extinction
PG-13

Friday & Saturday
August 15 & 16

All Tickets - \$7.00
Show starts at dusk.
Gates open at 7:30.

Like us on facebook or check us out at www.sandelldrivein.com

Summer storms? Watch Out for scam contractors

Hi, gang! When you read this I will be back from MDA in Houston, and Lord willing I will have some "good news."

It time for those pesky storm chasers to come out of the wood works to pray on inspecting victims. The storms that blow through during this time of year can leave downed trees and other damage in their wake. That's when "storm chasers" appear. These scam contractors prey on homeowners by promising repairs, collecting a fee and failing to deliver.

How the Scam Works: A major windstorm just blew through your city, knocking a tree onto your roof. The next day, a contractor appears at your door. You are generally suspicious of door-to-door salespeople, but this offer is very tempting. The contractor gives you a great price, and, if you commit now, he can begin work the next day. The contractor will either want upfront pay-

ment or for you to sign a contract allowing the business to negotiate with your homeowners insurance on your behalf. Do this, and your entire insurance check may go to the storm chaser regardless of the quality or quantity of work completed.

After approving the work, several things may happen. Some storm chasers complete the job as described. However, poor craftsmanship and materials mean that you need the roof repaired again a few months later, when the business has moved on to a new storm-damaged region. In more extreme cases, contractors may simply take your payment, completing part or none of the work, and disappear.

Tips to Protect Yourself from "Storm Chaser" Scams: When a storm hits, follow these tips to ensure that any repairs go smoothly. Get three to four quotes: The storm chasers will try to pressure you into

making a decision immediately. Don't fall for it. Just as you would for a standard home improvement project, get at least three quotes before making a decision.

Check references: Get references from several past customers. Make sure these are at least a year old, so you can check on the quality of the work. Check bbb.org: BBB Business Reviews are more than just a grade. You can also read past complaints from customers, find out about licensing and government actions, and more. Make sure it's legal: Confirm that any business being considered for hire is licensed and registered to do work in your area. Also, if in doubt, request proof



bob's whittlin'
by bob watson

of a current insurance certificate from a contractor's insurance company. Get it in writing: And always be sure to get a written contract with the price, materials and timeline. The more detail, the better. Be very careful these scammers are slick.

A friend posted on Facebook: Hey I was just sent this email from Amazon: Has anyone else got this before? I don't want to fill out the information if it is a scam. It does take you directly to Amazon website. Congratulations! You Are The Winner Of a Coupon For \$1,000

Ticket Number: 56/100
Dear Amazon Customer,
This is a random selection from Amazon.com on the occasion of this Summer 2014, we selected more than one million customers in first step then we chose just one hundred other customers also randomly to be winner of a coupon for \$1,000.
In order to get your coupon

ticket code winner, you have to complete a short survey.

If you don't know how to complete it, read this instructions:

1) Click complete survey in the link below and you will access to your account.

2) Enter required information and submit it.

3) Wait couple of seconds and your coupon will start.

Complete Survey:
NOTE: You have to enter your real information to confirm you are not a robot, if you use fake information your download won't unlock and you lose your coupon ticket code.

Thank you, Amazon Online Shopping Team

This is a scam, beware spelling errors. Also spammers can make it look like a company's web site. As always if it looks like it's too good to be true, it isn't.

High winds blow through H-Wick

Well, folks, if you remember a few weeks ago in my discussion of Greenbelt Lake, I said it would take "a Big One" to give us enough rain to fill it up. We did receive a "Big One" Friday night but not exactly what I had in mind.

Storms were brewing west of Clarendon while my great-grandsons and I enjoyed a nice sunny afternoon with outdoor plans for the evening. I checked Doppler Dave's weather page and quickly realized we would be staying home because those storms filled with lightning were headed for Donley County.

What a storm it was! It hit us about 6:30 p.m. with gale-force winds and rain coming down in sheets but blowing so hard much missed the rain gauge. We had sustained winds of 45-50 mph, I heard of gusts up

to 80 mph then we lost electricity.

Have you been in a storm with three boys, ages 8, 10, and 11, with no electricity? They were very nervous even though our roof was intact, no windows shattered and cars were sheltered. It was so dark you could not see the damage being done to other parts of Howardwick.

Our electricity came back on about 10:30 p.m. Thank you, Greenbelt Electric, you are the best.

Saturday morning showed the extent of the damage, and it is extensive, especially to trees and

roofs.

As you drive into Howardwick trees and limbs are strewn along the roadside and the golf course, trees are snapped in yards, the park could be compared to a war zone. Then we come to structural damage. Many roofs are blown off including the roof of the unoccupied Canteen across from the Baptist Church and City Hall.

Signs are blown over, out buildings blown over, I heard of a carport blowing over and hitting two cars but as far as I know there were no injuries during the storm.

Thank you, Lord, for sparing us injury, for the rain of 1.30 in our gauge, for pruning our trees, and for providing clean-up jobs for many people; but next time I ask for "The Big One" I will be more specific.



'wick picks
by peggy cockerham
Howardwick • 874-2886

Donations being taken for Eleanor Christie

The Hedley Senior Citizens are asking for donations for one of their employees, Eleanor Christie.

On July 11, Eleanor was taken to the Emergency Room in Childress with an infection in her groin area. The infection was killing her soft tissues which turned into gangrene. She was sent to Lubbock UMC that night, and she has had three (3) surgeries within a few days. After about three weeks, she was sent to Lakeside Rehab in Lubbock, but she was scheduled to have another surgery Monday, August 11. They said they got all of the gangrene and

this surgery will be for skin grafts if it is ready.

I understand she won't be going back to the rehab place after surgery, and I don't know where they will send her. She has run out of her Medicare days, and we are trying to get her on Medicaid, but I don't know how that will work. If you would like



chatty kathy
by kathy spier
Hedley • 856-5302

to help her there will be a donation jar at Lowe's in Clarendon and at Thriftway in Memphis or you can send your donation to the Hedley Senior Citizens, PO Box 216, Hedley, TX, 79237 in care of Eleanor Christie. Please indicate that it is for Eleanor. She really needs some help.

Also, she has been feeding stray cats in Hedley, and we are looking for barns or homes to help her. Is anyone looking for barn cats or even a kitten to take home? Call Kathy at 806-856-5302. We have already got homes for about 10, but there are more.

Five generations celebration birthday

Lucy Favette Crocker of Pampa (now living at Saints Roost Assisted Care in Clarendon) celebrated her 98th birthday July 11. Nancy Owens prepared the wonderful food and decorations for the party. Fellow residents, relatives, and friends attended the celebration. The five generations are: Favette Crocker, her daughter, Ginger Stone of Clarendon, granddaughter, Laurie Holcomb of Sweetwater, Tex, great granddaughter Whitney Lamming of Lubbock, Tex, great granddaughter Ashley Cardwell of Wichita Falls, and her great great granddaughter, Brooklyn Grace Cardwell of Wichita Falls, Tex. She also has a great great grandson, Brady Holcomb of Lubbock, who was unable to attend. Favette Crocker has been deaf since the age of three and uses sign language.



Favette Crocker, Ginger Stone, Laurie Holcomb, Whitney Lamming, Ashley Cardwell, Brooklyn Grace Cardwell.

DEADLINES

News & Photos Monday @ noon
Ads & Classifieds Monday @ 5 p.m.

OSBURN APPLIANCE AND SERVICE

Now Carrying New Appliances
Ranges • Refrigerators • Washers • Dryers
General Electric, Whirlpool, Frigidaire, and others

Rebuilt Used Appliances For Sale • Will Buy Used Appliances In Good Condition

874-3632

319 S. Kearney

'Pear' of pickers

I spent Sunday afternoon with Ella helping our Dad pick up pears and pick pears in our backyard. The pears are large and small. Sometimes you have to stand up on your tippy toes to reach the pears.



the cub reporter
by benjamin estlack

My big cousin Nathan also picked me up so I could reach. We also have a pear picker, on the end is a claw where you can basically put the claw at the top of the pear where the stem is and pull really hard and the pear falls in a basket.

I don't like to eat pears, but I like to give them to other people because it makes me feel good. If you'd like some pears, just let my Mom or Dad know, and I will pick some for you.

weather report

Day	Date	High	Low	Prec.
Mon	4	90°	63°	-
Tues	5	92°	62°	-
Wed	6	99°	62°	.02
Thur	7	100°	70°	-
Fri	8	91°	66°	.34
Sat	9	91°	66°	T
Sun	10	84°	65°	-

Total precipitation this month: 4.49"
Total precipitation to date: 12.01"

weekend forecast

Fri., August 15
Partly Cloudy
96°/73°

Sat., August 16
Mostly Sunny
97°/71°

Sun., August 17
Mostly Sunny
98°/72°

Information provided by:
Lori Howard
National Weather Service

THANK YOU
Bon Umruh of Pampa is the Radio Cooler Winner!
Thank you so much to all who purchased tickets and made donations for us. Also thanks to everyone who participated in any way at the Bake Sale that was held at Lowe's grocery store in our honor. We appreciate it so much. Words just can't do it justice.
Keith and Beverly Taylor of Howardwick

Buy ♦ Sell ♦ Trade ♦ Give Away
Joe's Flea Market
Mon. ♦ Wed. ♦ Fri.
at 9 a.m.
KLSR 103.3 FM

Drugs in the News

Promising Treatment for Pulmonary Fibrosis
Currently, there are no approved treatments for idiopathic pulmonary fibrosis (IPF) available in the US. However, pirfenidone and nintedanib, drugs manufactured by two separate companies, have both recently shown promising results in clinical trials. Pirfenidone has been shown to reduce inflammation and fibrosis by reducing the production of inflammatory mediators in the body. Recent phase III clinical trials have shown pirfenidone to significantly decrease IPF disease progression. Nintedanib targets growth factors, which have been shown to possibly be involved in IPF. Currently in undergoing phase III trials, nintedanib has been granted priority review by the FDA in order to speed up the approval process.

Idiopathic pulmonary fibrosis is a lung condition characterized by scarring and hardening of the lung tissue. There is a progressive worsening of lung function. Ultimately, it is a fatal condition. IPF typically affects individuals aged 50 to 70 years old with a history of smoking. Treatment in the past has centered around reducing symptoms, slowing down disease progression, and prolonging life.

Rx Mike's PHARMACY
Call 874-3554 or Toll Free 800-766-2089
Hwy 287 West • Clarendon, Texas

Hill appointed to SWCD board

Johnny Hill of Hedley was appointed to represent subdivision five of the Donley County Soil and Water Conservation District. Johnny Hill fills the unexpired term of Doug Wright who served on the board for 15 years. The Donley County SWCD's headquarters is located in Clarendon, Texas.

Hill operates a livestock operation.

In addition to his agricultural enterprise, Hill is also employed by Texas Department of Criminal Justice.

Hill is a current member of Texas State Rifle Association, National Rifle Association, American Quarter Horse Association, Working Ranch Cowboys Association and High Plains Rancher & Breeders Association.

"The Donley County SWCD's purpose is to make available to local landowners and operators' technical, financial and educational resources to help them better conserve the soil, water and related resources which they manage or own," said Dick Bode chairman of the district.

The Donley County SWCD is a political subdivision of state government and is divided into five subdivisions. Subdivision 5's boundaries are south of Highway 287 and east of FM 1260.

"We want to welcome Johnny Hill as a member of our board of directors. As a member of our board he will play a significant role in helping our district provide technical assistance to our district cooperators who wish to implement conservation programs on their land," said Dick Bode chairman of the district.

TxDOT offers Back-to-School driving tips

The end of summer means millions of Texas children will soon return to school. TxDOT reminds drivers to be extra cautious as school zones become more active.

Last year, 625 vehicle crashes occurred in school zones in Texas, resulting in two deaths and 112 serious injuries. August and September of 2013 alone saw 104 crashes in school zones. The most common factors contributing to these crashes were driver inattention, failure to control speed and failure to yield the right-of-way at stop signs.

Following these simple tips can help Texas children reach school safely and help drivers avoid costly fines and tickets. Tips for Driving in School Zones:

- Put away your cell phone. Cell phone use is banned in active school zones, and violators face fines of up to \$200 in school zones where signs

are posted.

- Always obey school zone speed limit signs. Remember, traffic fines usually double in school zones.

- Drop off and pick up your children in your school's designated areas, not the middle of the street.

- Keep an eye on children gathered at bus stops.

- Be alert for children who might dart across the street or between vehicles on their way to school.

Tips for Children Walking or Biking to School:

- Always cross at intersections and designated crosswalks. Look left, right and then left again before proceeding.

- Look for traffic when stepping off a bus or from behind parked cars.

- Make eye contact with drivers before crossing the street.

- Always obey crossing guards.

- Always wear a helmet when riding a bicycle.

Tips for Sharing the Road with School Buses:

- Always stop for flashing red lights on a school bus, regardless of which direction you're headed.

- If you are on the other side of a divided highway, you do not have to stop for a bus with flashing red lights, but please still use caution as children are around.

- School buses stop at all railroad crossings, so be prepared to stop if you are behind a bus.

- Watch for children who might run across the street as they get on or off the bus.

Visit <http://www.txdot.gov/driver/kids-teens/school.html> for campaign downloads and more information, and check us out on Facebook at <http://www.facebook.com/TxDOT>.

Broncos to scrimmage Bovina

By Sandy Anderberg

The Clarendon Broncos have been practicing since the first week of August and will go up against Bovina this Friday, August 15, at 5:00 p.m. in Bronco Stadium.

The 44 athletes out for football this season will test their skills in a scrimmage this week to get a feel of where they are as they prepare for their 2014 season. According to head coach Gary Jack, the players have been working hard.

"We have a good group of guys this year," Jack said. "Right now we have 44 playing and really have a

good chemistry. We are still pretty young with a few seniors. So we will probably be starting a lot of sophomores." Jack said they are looking forward to getting things started and will travel to Electra for another scrimmage on the August 22. The Broncos will have a little time to hone their skills and gel as a team as they trudge through their pre-district schedule in the next few weeks.

"Our pre-district schedule is fairly tough," Jack said. "The teams we have early in our schedule all reached the play offs last year. But so far we are pleased with their effort."

Jarnagin, Auvenshine shoot age

Golfers Steve Jarnagin and Bill Auvenshine had a great day on the golf course last Wednesday in the weekly men's game, turning in low scores.

Jarnagin, who is 77 years young, turned in a 74 for the round, which was good enough to top the field. Auvenshine, who is also 77 years young, turned in a 77. He won low net with his handicapped score of 69. Chris Linquist won second low gross with an 80. Sherol Johnston won low gross in the weekly women's game on Thursday with an 86. Ouida Gage won low net with a handicapped score of 65, and Gail Leathers was second with a 72.

There will be an 18-hole night scramble Saturday, August 16, beginning at 6:00 p.m. Nine holes will be played in the light of the day and the remaining nine holes will be played after dark with glow-in-the-dark equipment. You may call the Pro Shop to enter.

Lubbock workshop to focus on poultry

LUBBOCK - Anyone interested in learning more about keeping a home chicken flock should attend the Texas A&M AgriLife Extension Service's Backyard Poultry Production workshop set from 6-8 p.m. August 18 in Lubbock.

The workshop will be held at the AgriLife Extension office, 916 Main St., Suite 201. Attendees are asked to enter the building through the south doors on Main Street. Individual registration is \$15, due upon arrival, said Robert Scott, AgriLife Extension agent in Lubbock. RSVP by noon Aug. 18 to the AgriLife Extension office in Lubbock County at 806-775-1680 or email Scott at rj-scott@tamu.edu.

"Keeping a small flock of chickens for home use, a practice commonplace during our grandparents' time, is seeing a resurgence today for a number of reasons," said Scott.

"Dr. Greg Archer, AgriLife Extension poultry specialist at College Station, our keynote speaker, will touch on some of those reasons, as he also provides a broad introduction for those wanting to keep a small flock of laying hens."

Scott said participants will learn about poultry feeding, health and egg production, as well as food safety in handling homegrown eggs.



the lion's tale
by roger estlack

The Clarendon Lions Club held with Boss Lion Larry A. Capranica in command.

We had 14 members and two guests this week - Nathan and Daniel Estlack, guests of Lion Russell Estlack.

Lion Robert Riza reported on college activities, and other news around town was discussed briefly.

Plans were made for a work day this Saturday, August 16, to help spruce up the Lions Hall in conjunction with the newly remodeled offices for The Bridge children's advocacy center at the back of the building. All Lions members are asked to show up at 9 a.m. with their working clothes and tools.

Lion Richard Sheppard presented a short trivia program.

There being no further business, we were adjourned.



BREAKFAST CHALLENGE

Eat our meal in 30 minutes or donate \$20⁰⁰

OPEN Monday - Friday 6 a.m. - 10 a.m. Sat. 6:30 a.m. - 10:30 a.m.

LOW BUCK STORAGE 822-0442

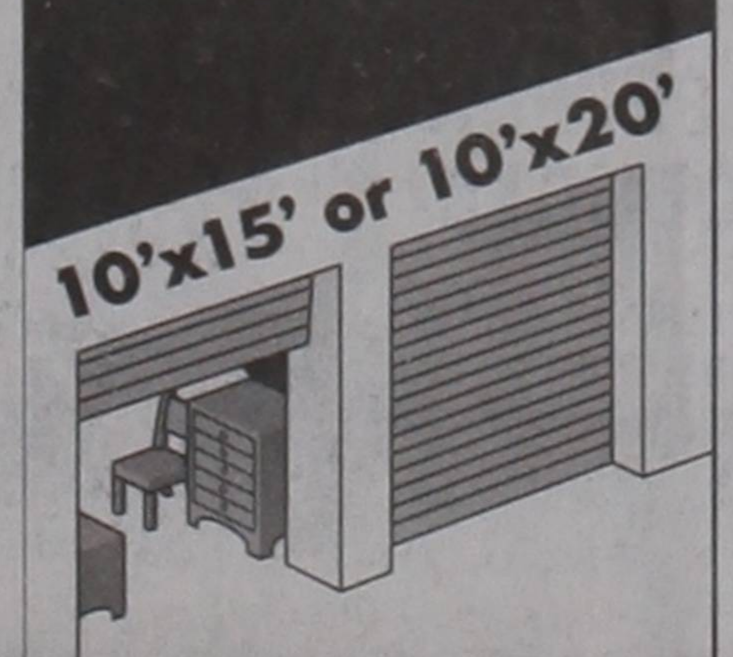

Subscribe Today. Call 874-2259.

Joey & Brenda Lee
Lee's Insurance
PO Box 189 • Clarendon, Texas 79226
806.874.2130

HOME • AUTO • LIFE • COMMERCIAL

PHELPS PLUMBING heating • air-conditioning

806-874-1675

HVAC# TACL3255E PLUMBING # 12746

Back To School TIRE SALE

Cooper Discover

24 HR. 287 TIRE & TUBE SERVICE

NEW & USED TIRES • QUALITY SERVICE

Daytime: 874-0213 317 W. 2ND • CLARENDON

Nights: 336-1166 (NATHAN) 205-1137 (DUSTIN) 662-6336 (CHARLES)

Get What You Need for Your Summer Projects

We carry Repair Parts for Horse Trailers and Utility Trailers!

Trojan BATTERY COMPANY

GOLF CART BATTERIES

See us for custom made HYDRAULIC HOSES

Made to fit hoses for high pressure hydraulic fluid lines.

Floyd's AUTO SUPPLY 874-2755 317 W. 2ND • CLARENDON

PARTS 4 PLUS

Worship DIRECTORY

CLARENDON

AGAPE CHRISTIAN CHURCH
712 E. 2ND (HWY 287) • MINISTER: ANTHONY KNOWLES
SUN. SCHOOL: 9:30 A.M. • SUN. SERVICE: 10:30 A.M.

CALVARY BAPTIST CHURCH
US 287 E • 874-3156 • REV. ROB SEALE
SUN. SCHOOL: 10 A.M. • SUN. SERVICE: 11 A.M.
SUN. EVENING: 7 P.M. • WED.: 7 P.M.

CHURCH OF CHRIST
300 S. CARHART • 874-2495 • MINISTER: CHRIS MOORE
SUN. BIBLE CLASS 9:30 A.M. • SUN. SERVICE: 10:30 A.M.
SUN. 6 P.M. • WED.: 7 P.M.

CHURCH OF NAZARENE
209 S. HAWLEY • 874-2321 • PASTOR: BILL HODGES
SUN. SCHOOL: 9:30 A.M. • SUN. SERVICE: 10:30 A.M.
SUN. EVENING: 6 P.M. • WED.: 7 P.M.

COMMUNITY FELLOWSHIP CHURCH
12148 FM 2162 • 874-0563
PASTOR: LARRY CAPRANICA
SUN. SCHOOL: 10 A.M. • SUN. SERVICE: 11 A.M.
SUN. EVENING: 6 P.M. • WED. COMMUNITY KIDZ 5:30 P.M.
WED. ADULT BIBLE STUDY: 6 P.M.

FIRST CHRISTIAN CHURCH
120 E. THIRD ST. • PASTOR: DARRELL BURTON
SUNDAY SERVICE: 5 P.M.

FIRST ASSEMBLY OF GOD
4TH ST. & HWY. 70 SOUTH • PASTOR: MATTHEW STIDHAM
SUN. SCHOOL: 9:45 A.M. • SUN. SERVICE: 10:40 A.M.
SUN. EVENING: 6 P.M. • WED. YOUTH: 6:15 P.M.
WED. BIBLE STUDY: 7 P.M.

FIRST BAPTIST CHURCH
300 BUGBEAVE AVE. • 874-3833 • REV. LANCE WOOD
SUN. SCHOOL: 9:45 A.M. • SUN. SERVICE: 10:55 A.M.
SUN. EVENING: 6 P.M. • KID'S ACTIVITIES: WED. 6 P.M.
YOUTH STUDY: WED. 7 P.M.
COLLEGE MINISTRY: WED. 9 P.M.

FIRST PRESBYTERIAN CHURCH
FOURTH & PARKS • PASTOR: REV. ROBIN GANTZ
FELLOWSHIP: 10:30 A.M.
SUN. SERVICE: 11 A.M.

FIRST UNITED METHODIST CHURCH
420 S. JEFFERSON • 874-3667 • PASTOR LLOYD STICE
SUN. SERVICE: 9:45 A.M. • SUN. SCHOOL: 11 A.M.

JESUS NAME APOSTOLIC CHURCH
720 E. MONTGOMERY • 205-1149 • REV. 874-2078
REV. CALVIN BURROW
SUN. SERVICES: 3 P.M. • WED.: 7 P.M.

BODY OF CHRIST MINISTRIES:
501 S. MCCLELLAND • PASTOR: R.W. ELLERBROOK
SATURDAY: 6 P.M. • SUNDAY DISCIPLESHIP CLASS: 9:30 A.M.
SUN.: 10:30 A.M. • SUN. LIFE GROUP: 4:30 P.M.
WED.: 6:30 P.M.

CHRIST'S KIDS OUTREACH MINISTRY:
416 S. KEARNEY • JANET & STEVE CARTER • 874-2007
SUN. BREAKFAST 9:30 A.M. • SUN. PRAISE & WORSHIP 10 A.M.
SUNDAY SCHOOL: 10:30 A.M. • WED.: 5 P.M.

ST. JOHN THE BAPTIST EPISCOPAL CHURCH
301 S. PARKS ST. • 874-2511 • REV. JIM AVERI
FIRST SUNDAY SERVICE: 11 A.M.

ST. MARY'S CATHOLIC CHURCH
MONTGOMERY & MCCLELLAND
FR. ARODIA RAJ SAMALA
SUN. MASS 11 A.M.

ST. STEPHENS BAPTIST CHURCH
300 N. JEFFERSON ST. • PASTOR: ROY WILLIAMS
SUN. SCHOOL: 10 A.M. • SUN. SERVICE: 11:15 A.M.
WED.: 7 P.M. (WEATHER PERMITTING)

TRUE CHURCH OF GOD & CHRIST
301 N. JEFFERSON • ST. PASTOR: JEFF REES
SUN. SCHOOL: 10 A.M. • SUN. SERVICE: 11:15 A.M.
WED.: 7 P.M.

ARENA OF LIFE COWBOY CHURCH
214 S. KEARNEY • PASTORS: BUNK & AMY SKELTON
SUN. SCHOOL: 10:30 A.M. • WED. BIBLE STUDY: 7 P.M.

HEDLEY

CHURCH OF CHRIST
110 E. SECOND ST. • MINISTER: BRIGHT NEWHOUSE
SUN. BIBLE CLASS: 10 A.M. • SUN. SERVICE: 11 A.M.
SUN. EVENING: 6 P.M. • WED.: 7:30 P.M.

FIRST UNITED METHODIST CHURCH
200 N. MAIN ST. • PASTOR: STAN COSBY
SUN. SERVICE: 4:00 P.M.

FIRST BAPTIST CHURCH
210 N. MAIN ST. • 856-5990 • PASTOR: BRUCE HOWARD
SUN. SCHOOL: 10 A.M. • SUN. 11 A.M. & 6 P.M.
WED.: 7 P.M.

HOWARDWICK

FIRST BAPTIST CHURCH
235 RICK HUSBAND BLVD. • 874-3326 • REV. DAVE STOUT
SUN. SCHOOL: 10 A.M. • SUN. SERVICE: 10:45 A.M.
SUN. EVENING: 6 P.M. • WED.: 6 P.M.

OLD PATHS PRIMITIVE BAPTIST CHURCH
HEREFORD LANE AT HWY 70 • 673-1770
3RD SUNDAYS - DON MARTIN • 4TH SUNDAYS - DON WATSON
SERVICES: 10:30 A.M.

MARTIN

MARTIN BAPTIST CHURCH
US 287 W.
SUN. SCHOOL: 10 A.M. • SUN. SERVICE: 11 A.M.
SUN. EVENING: 6 P.M. • WED.: 7 P.M.

BRICE

BRICE DELIVERANCE TABERNACLE
PASTOR: LOUIS BENNETT
SUNDAY: 9:45 A.M. • SUN. EVENING: 6 P.M.
WED.: 6 P.M.

SPONSORED BY ROBERTSON FUNERAL DIRECTORS

COUNTRY BLOOMERS FLOWERS & GIFTS

WALLACE MONUMENT CO.

MCKINNEY MOTOR CO.

3-H ALL NATURAL BEEF

CLARENDON FAMILY MEDICAL CENTER

ROLLING PLAINS AG COMPOST

J&W LUMBER

PILGRIM BANK

For corrections or additions, call the Enterprise at: 874-2259

2014 Clarendon Cross Country Schedule

Date	Meet	HS/JH
Aug. 30	Borger	HS/JH
Sept. 9	Plainview	HS/JH
Sept. 13	Amarillo	HS
Sept. 20	Open	HS/JH
Sept. 27	Lubbock	HS
Oct. 4	Canyon	HS/JH
Oct. 11	Spearman	HS/JH
TBA	DISTRICT	HS/JH
Nov. 1	Regional Meet	HS
Nov. 8	State Meet	HS

Obituaries

Hall

Truett Eugene Hall, 86, died Saturday, August 9, 2014, in Amarillo.



Hall

Services were held Wednesday, August 13, 2014, at the First United Methodist Church in Clarendon with Rev. Kirk Watson, pastor, and Rev. Bruce Howard, officiating.

Arrangements were under the direction Robertson Funeral Directors of Clarendon.

Burial followed at Citizens Cemetery in Clarendon.

Truett Hall was born November 17, 1927, in Gruver, Texas to Durell K. and Dessie McFarland Hall. He married Fern O. Gibbs on May 13, 1948, in Amarillo. Mr. Hall had served his country in the US Army and was a veteran of World War II. Truett attended the Naylor School, where he rode his horse to school. The house where Truett had lived most his life was less than a mile from where he started first grade. He grew up working in the dairy business near Hedley and eventually would run the dairy at Wayside

in the 1950's. Truett coached many kids with the Kids, Inc. program in Amarillo as his children grew up. Mr. Hall was a hard worker and saw that he and his family were always taken care of. Truett had built several homes in the Clarendon area, including the First Church of the Nazarene parsonage and had done most of the carpentry work during the construction of the First Baptist Church. Most of all, Truett loved to farm and ranch. He was self-sufficient in his work, but always was willing to help others, especially his family when it came time to harvest. Truett was a quiet man that kept to himself, but when he spoke, people listened. He was a member of the VFW in Clarendon and was also a member of the First United Methodist Church in Clarendon.

He was preceded in death by his parents; his wife, Fern Hall; a brother, Emmett Hall; a sister, Vivian Harris; and by a grandchild, Charlie "Gene" Hall.

He is survived by 2 sons, James Hall of Chelton, Texas, John Hall and wife Loretta of Hedley; 2 daughters, Shirley McCulloch and husband Michael of Clarendon, and Truetta Brandt and husband Gerald of Amarillo; 11 grandchildren; and 16 great grandchildren.

The family request that memorials be made to BSA Hospice or to Citizens Cemetery Association in

Clarendon.

Sign our online guest book at www.RobertsonFuneral.com

Zanardi

Debra Lynn Zanardi, 51, of Borger died Sunday August 1, in Amarillo. Memorial services will be held at 2:00 p.m. Thursday, August 14th, at Faith Covenant Church in Borger with Rev. Danny Courtney of First Baptist Fritch, TX officiating. Cremation is under the direction of Minton Chatwell Funeral Directors of Borger.

Debra was born March 26, 1963, in Ponca City, OK to Melvin and Guyretta Baker Clinton. She married Mark Zanardi June 16, 1990, in Ponca City, OK. She was a resident of Borger since 1995 coming from Winfield, KS. She was a teacher's aide for the Borger Independent School District. She was a member of First Baptist Church in Turkey, TX.

She was preceded in death by her mother.

Debra is survived by her husband Mark. Father Melvin Clinton of Turkey, TX. Son Deric Zanardi of Borger. Daughters Miranda Zamardi of Borger and Jennifer Zanardi of Ark City, KS. Brother Gary Clinton of Silverton, TX. Sister Karen Rice of Howardwick, TX. Two grandchildren Allys and Kaden Zanardi.

Subscribe Today to the Enterprise!

NOTICE OF PUBLIC MEETING TO DISCUSS BUDGET AND PROPOSED TAX RATE

The Hedley ISD will hold a public meeting at 6:30PM, August 28, 2014 in Board Room, Hedley ISD

The purpose of this meeting is to discuss the school district's budget that will determine the tax rate that will be adopted. Public participation in the discussion is invited.

The tax rate that is ultimately adopted at this meeting or at a separate meeting at a later date may not exceed the proposed rate shown below unless the district publishes a revised notice containing the same information and comparisons set out below and holds another public meeting to discuss the revised notice.

Maintenance Tax	\$ 0.99000 / \$100 (Proposed rate for maintenance and operations)
School Debt Service Tax	\$ 0.06000 / \$100 (proposed rate to pay bonded indebtedness)
Approved by Local Voters	

Comparison of Proposed Budget with Last Year's Budget

The applicable percentage increase or decrease (or difference) in the amount budgeted in the preceding fiscal year and the amount budgeted for the fiscal year that begins during the current tax year is indicated for each of the following expenditure categories:

Maintenance and operations	0.00	% increase	or	12.09	% (decrease)
Debt service	2.05	% increase	or	0.00	% (decrease)
Total expenditures	0.00	% increase	or	11.31	% (decrease)

Total Appraised Value and Total Taxable Value (as calculated under Section 26.04, Tax Code)

	Preceding Tax Year	Current Tax Year
Total appraised value* of all property	\$ 170,177,204	\$ 206,837,902
Total appraised value* of new property**	\$ 19,140	\$ 28,561
Total taxable value*** of all property	\$ 45,575,219	\$ 54,284,985
Total taxable value*** of new property**	\$ 19,190	\$ 28,561

* "Appraised value" is the amount shown on the appraisal roll and defined by Section 1.04(8), Tax Code.
 ** "New property" is defined by Section 26.012(17), Tax Code.
 *** "Taxable value" is defined by Section 1.04(10), Tax Code.

Bonded Indebtedness

Total amount of outstanding and unpaid bonded indebtedness* \$ 175,000

* Outstanding principal.

Sheriff's Report

August 4, 2014

10:57 a.m. Report of hazardous power lines 400 block of E. Fifth.

11:17 a.m. Report of hit and run 400 block of W. Second.

12:03 p.m. Report of ill or intoxicated subject 200 block of W. Fifth.

1:42 p.m. EMS assist 300 block S. McLean.

4:14 p.m. EMS assist 500 block S. McLean.

6:45 p.m. Civil service 500 block S. Parks.

August 5, 2014

1:11 a.m. EMS assist 500 block S. Jackson.

7:03 a.m. EMS assist 200 block S. Goodnight.

11:51 a.m. Report of vehicles racing on Fifth Street.

4:42 p.m. EMS assist 800 block S. Johns.

5:16 p.m. EMS assist 287 eastbound

near college arena.

7:55 p.m. EMS assist in Hall County.

10:10 p.m. EMS assist 200 block of S. Parks.

11:11 p.m. Loose livestock on FM 2362.

August 6, 2014

5:15 a.m. EMS assist 600 block W. White.

8:33 a.m. Loose livestock FM 3257.

5:13 p.m. See caller 500 block E. Fourth.

5:15 p.m. EMS assist at EMS station.

11:47 p.m. Removing debris off highway at Sully St.

August 7, 2014

1:14 a.m. Residential burglar alarm, 12100 block FM 2362.

1:57 a.m. EMS assist 800 block S. Kearney.

9:18 a.m. Out at courthouse.

9:38 a.m. Out at courthouse.

6:42 p.m. EMS assist 12500 block CR P.

7:21 p.m. Reporting domestic at 600

block W Second.

7:57 p.m. Loose livestock FM 2471.

11:19 p.m. Reporting small fire at CHS football field.

August 8, 2014

9:40 a.m. EMS assist 12500 block CR P.

11:51 a.m. Units paged to accident 900 block W. Second.

2:55 p.m. Mutual aid with McLean EMS.

3:14 p.m. EMS assist 300 block E. Barcus.

5:56 p.m. Howardwick fire units out for storm watch.

6:29-7:40 p.m. Damage reports from Howardwick.

7:34 p.m. EMS standby at Haskell and Pampa streets in Howardwick.

August 9, 2014

1:58 a.m. EMS assist at EMS station.

1:00 p.m. Residential burglar alarm 13500 block FM 2471.

2:30 p.m. Residential alarm 13400 block CR V.

Prices Good Thru 09/06/14

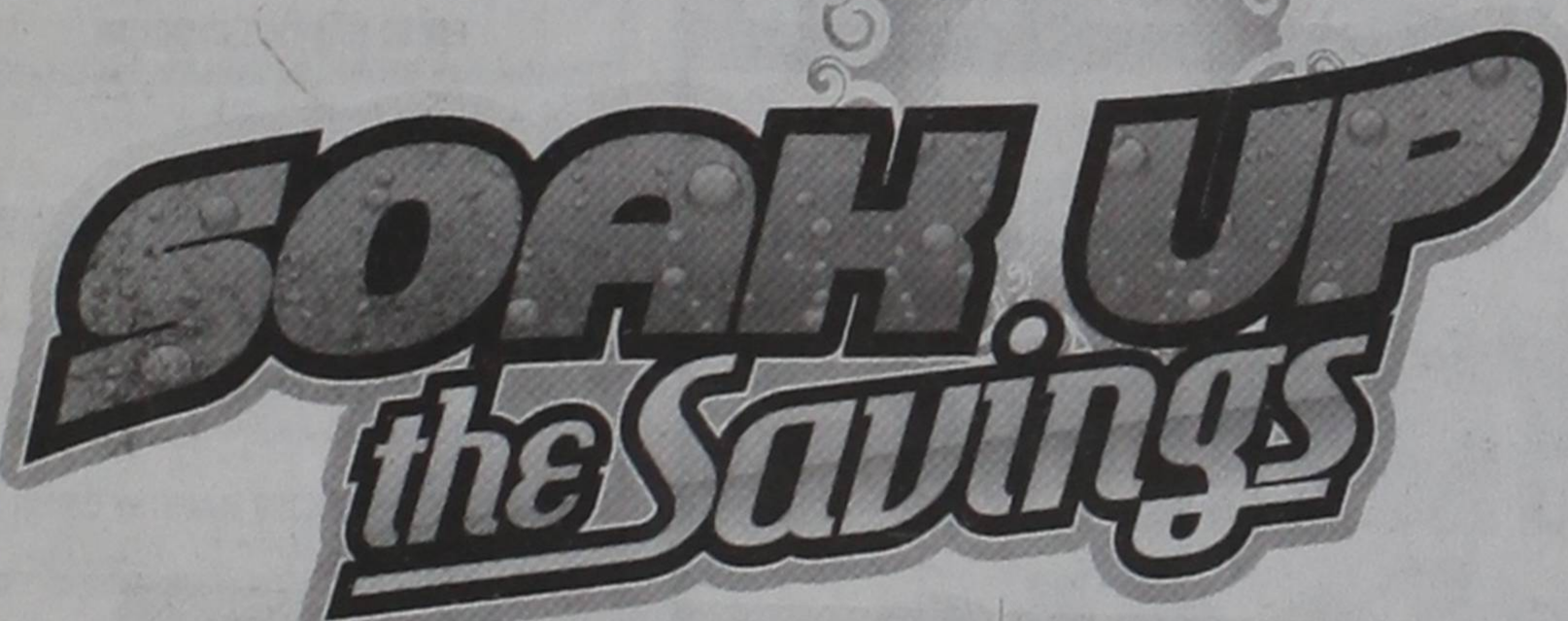

STORE #48
701 WEST 2ND STREET
CLARENDON, TEXAS 79226
806-874-3906



"Hunger Stops Here"

WORLD FAMOUS BURRITO!

- Born 1974
- 40 Years Old
- Seeking Lunch Date

I was discovered by accident but my flavorful beef & bean filling have made me World Famous!

\$1.79 ALLSUP'S 40th Anniversary Beef & Bean Burrito

OR MAKE IT A COMBO

2 BURRITOS & 2 BEV. CALLUPS

ONLY \$3.99

SAME GREAT TACO SAUCE NOW IN A BOTTLE!

5 oz.

\$1.99

EXTRA SAVINGS

BLUE BUNNY BIG ALASKA BAR 99¢
EACH

CHICKEN & CHEESE FLAUTAS AND A 32 OZ. TALLSUP

\$3.99

BLUE BUNNY PERSONALS 99¢
EACH

SQUATCH STICKS 99¢
1 OZ.

STRIDE GUM ALL VARIETIES 99¢

SPECIAL K BARS \$1.29
EACH

MTN DEW PRODUCTS 24 OZ. CANS 2\$3 FOR 3

GATORADE SPORTS DRINKS 28 OZ. 2\$3 FOR 3

DR PEPPER PRODUCTS 12 PACK ONE AT REGULAR PRICE OR MIX AND MATCH FOR 2\$7 FOR 7

big E classifieds

Call in your ad at
874-2259

Deadline: Monday @ 5 p.m.
Prepayment required.
Visa / MasterCard accepted.



MEETINGS

Clarendon Lodge #700 AF&M
Stated meeting: Second Mondays, 7:30 p.m. Refreshments at 6:30 p.m. Practice: Fourth Mondays, 7 p.m. Jim Owens - W.M., Grett Betts - Secretary, 2 B I, ASK I

Donley County Memorial Post 7782 Veterans of Foreign Wars
Meets first Tuesday at 7 p.m. 822-VETS.

Clarendon Lions Club Regular meeting each Tuesday at noon. Ashlee Estlack, Boss Lion. Roger Estlack, Secretary

Clarendon Chamber of Commerce Regular meeting 2nd Thursday each month at 5:30 p.m. at Burton Memorial Library.

Big E Meeting Listings only \$8.50 per month. Call 874-2259 to have your club or organization meeting listed.

ANNOUNCEMENTS

Saints' Roost Museum
610 East Harrington
Tuesday - Saturday
10 a.m. to 5 p.m.
Open for appointments.
Call 874-2746.

FACILITIES AVAILABLE - Family Reunions, Receptions, Business Meetings, Club Functions, and more. Clarendon Lions Hall, 111 W. Fourth. Call 874-3521 for rental information.

GARAGE SALE

MULTI-FAMILY GARAGE SALE: Friday & Saturday from 8:00 a.m. - 5:10 Orpe at the Osburn's. Lots of boy's clothes- assorted sizes, women's clothes x-large & smaller, Star Trek stuff, and more.

HUGE HUGE YARD SALE: Saturday, August 16 from 8:00 a.m. - 3:00 p.m. 219 Arthur in Howardwick. Bookshelves, vintage bedroom set, loveseat, drop leaf table with two chairs, trunk, end tables, exercise equipment, and lots and lots of miscellaneous. Don't miss this one!

FOUR FAMILY GARAGE SALE: Thursday, August 14, from 7:00 a.m. - 6:00 p.m. and Friday, August 15, from 8:00 a.m. - 12:00 p.m. Located at 1102 West 8th Street. Glass top coffee table, washer & dryer, car seats, men's & kids clothing, kitchen items, coffee maker, bread maker, and much more.

HELP WANTED

BEST WESTERN RED RIVER INN is taking applications for a Maintenance Assistant. Please apply in person.

HELP WANTED: Must have a CDL and be able to operate a front end loader and a skid loader. Must be able to pass a drug test. Call Terri at Rolling Plains Ag Compost 806-205-0368.

NURSES UNLIMITED, INC. is seeking enthusiastic and outgoing attendants to assist clients in the home with personal care, meal prep and light housekeeping. P.T. E.O.E. Call 888-859-0631

ADMINISTRATIVE ASSISTANT Scheduling travel and expense reporting. Coordination of offsite meetings, i.e. booking rooms, developing agendas, send your cover letter and salary expectations to: esoun68@gmail.com James Young PO Box 726 Clarendon, TX 79226 214-838-6777

PUBLISHER'S NOTICE: All real estate advertising in this newspaper is subject to the Fair Housing Act which makes it illegal to advertise "any preference, limitation, or discrimination based on race, color, religion, sex, handicap, familial status, or national origin, or an intention, to make any such preference, limitation, or discrimination." This newspaper will not knowingly accept any advertising for real estate which is in violation of the law. Our readers are hereby informed that all dwellings advertised in this newspaper are available on an equal opportunity basis. To complain of discrimination, call HUD toll-free at 1-800-669-9777. The toll-free telephone number of the hearing impaired is 1-800-927-9275.

HELP WANTED

BEST WESTERN RED RIVER INN is taking applications for a Housekeeping Attendant. Please apply in person.

THE CLARENDON CHAMBER OF COMMERCE is taking applications for the position of Chamber Manager. Proposed schedule is 30 hours per week and primary duties include book-keeping, record keeping, maintaining communications, leading member services, coordinating Chamber events and activities, and developing strategies to promote local commerce. For a complete job description and an application, contact Bonnie Campbell at the Clarendon Visitor Center at the Mulkey Theatre or by calling 806-874-2421.

THE CLARENDON ECONOMIC Development Corporation is seeking applications for the Director of Tourism & Economic Development. The primary function of this position is to encourage appropriate tourism and business development for the City of Clarendon, direct and manage the Clarendon EDC and Clarendon Visitor Center, and provide supervision and counsel to the Clarendon Chamber of Commerce. Estimated job start time is September 1, 2014. For a complete job description, contact Chandra Eggemeyer at tourism@cityofclarendontx.com

Community Care Center IS NOW HIRING Experienced D.O.N's
Pay based on experience.
Please call June Davis or Cissy Hernandez at 874-5221.

Community Care Center IS NOW HIRING CNA'S & LVN'S
Pay based on experience.
Please call June Davis or Cissy Hernandez at 874-5221.

Community Care Center IS NOW HIRING A Business Office Manager
Pay based on experience.
Please call 874-5221.

Memphis Convalescent Center has the following openings. If interested in working for a 5 star facility and in a friendly environment come by and see us for any of these positions.
Weekend RN supervisor: Applicant will work weekend RN coverage for 8 hours per day. Applicant must have a RN license in good standing with the State of Texas.
PRN LVN: Working 12 shifts as a Charge nurse. Applicant must have a valid Texas Licensed nurse license in good standing with the State.
Floor Tech/maintenance helper: must do yard, tile floors and all other tasks to help maintenance supervisor. Applicant needs to have computer skills and able to do paperwork.
Director of Nurses, RN: Long term care experience preferred but not necessary. Applicant must have a valid Texas RN license in good standing with the State. Ability to supervise staff, ensure resident care, ensure resident care, ensure continues compliance with State and Company regulations. This position holds many responsibilities and takes a very dedicated, multi task individual with a distinct care for the elder.
Call 806-259-3566 or come by 1415 N. 18th Street in Memphis to apply.

HELP WANTED

SONIC YOU KNOW WHAT'S FUN?
Getting paid to be part of a team that knows everyone wins when everyone gets to be their own awesome self.
We like your spirit and we want to see you WORK IT here with us!

5591 State Number 79226 Zip Code

SONICDRIVEIN.COM / JOBS

APPLY NOW!

REAL ESTATE

Joe T. Lovell Real Estate
202 W. 3rd St.
Call 806-874-9318 to schedule a showing of the following listings.

Visit www.joetlovellrealestate.com to view pictures and details.

3 BEDROOM - 2 FULL BATHS - PLUS EFFICIENCY APARTMENT - 1850 sq ft main house - eat in kitchen - appliances & plentiful counter top & cabinet space - abundant built in storage & closets in all rooms plus hall - central heat/air - 24'X13' apartment with full kitchen - car garage - 2 car port - covered patio - fenced back yard - landscaped - large concrete cellar under garage with inside entrance - close to school & shopping area @ 609 W. 3rd for \$69,000.

EXCEPTIONAL 2 BEDROOM - ONE BATH - BRICK IN WEST CLARENDON - oversized attached garage includes shop with counter top and storage cabinets - like new kitchen cabinets & counter top - refrigerator -d/washer - work island/ breakfast table combo - pantry - living room includes mock fireplace with electric burner - bath with tub/shower - concrete cellar with shop/storage bldg. on top - 2 car port plus high rise RV port - beautiful patio with many extras - a must see @ 1305 W. 6th for only \$57,500.

HOUSE AND 2 1/2 ACRES, M/L. OF BEST COMMERCIAL DEVELOPMENT PROPERTY IN CLARENDON. some modern upgrades - potential for more - PROPERTY HAS FRONTAGE ON US HWY 287 ON NORTH, SIMS ST ON WEST AND 3RD ST ON SOUTH - an excellent investment for \$135,000.

GREENBELT LAKE
3 BEDROOM - 4 BATH - WITH NEW ROOF - large tress & lots of shrubbery - deer, turkey and wild birds enjoy this place and so will you - West side of lake on Lease Lots #27 - for \$145,000. REDUCED TO 137,500.

CLAUDE RESIDENTIAL
2323 SQ FT BRICK - open den/kitchen - built in appliances - beautiful wood cabinets - built in desk - Murphy bed in den - very large living/ dining room - 2 & 1/2 baths(one private with master bedroom) - large utility room - abundant storage - attached 2-car garage - central h/a - chain link fenced yard - efficiency apartment built over large concrete cellar - good location at 307 Western for \$135,000.

CLAUDE COMMERCIAL
CHOICE BUSINESS BUILDING SITE - Intersection of Hwy 287 and State Hwy 207 North with frontage on both busy highways. Diagonally across Hwy 287 from new Cefco complex - survey available.

RANCH AND FARMLAND
EXCEPTIONAL 2272 ACRE OPERATING AND HUNTING RANCH IN THE MIDDLE OF THE BEST DEER, TURKEY AND QUAIL HUNTING IN THE PANHANDLE - recently remodeled ranch home - abundant well water plus lake and large pond - good corrals - modern/rustic hunting lodge plus hunter's bunk house with cooking and sleeping facilities - the ideal working and recreational ranch - (DIVIDING INTO THREE TRACTS OF 1280 ACRES - 588 ACRES AND 403 ACRES +/- A POSSIBILITY) check out the pictures on www.joetlovellrealestate.com > Farms & Ranches > Collingsworth County - then call for details.

FOR RENT

FOR RENT: 2 bedroom. Call 874-0043 for more information.

FOR RENT: 1 bedroom house. Call 359-9395 for more information.

PUBLIC NOTICE

SURPLUS PROPERTY SALE NOTICE
August 8, 2014
Clarendon Consolidated Independent School District is accepting sealed proposals for the purchase of the following surplus property items:
Trailer: Shop Made (Ag. Dept.)
Date Built: 2007
Model: Goose Neck Flat Bed Trailer
Size: 20' x 8'
Minimum Acceptable Bid: \$ 3,200.00
Trailer: Stock Trailer
Year: 1979
Model: Hale (Full Covered Top - Purling Floor)
Size: 20' x 5.5'
Minimum Acceptable Bid: \$ 1,000.00
Sealed proposals must be received by the Clarendon CISD's Administration Office by 12:00 P.M. on August 28th, 2014. Interested proposers can contact Chad Hommel (Clarendon CISD Transportation Director) at (806) 874-4212 to arrange a viewing of the trailers. Clarendon CISD reserves the right to accept or reject any or all bids and to waive any technicalities.

SERVICES

SMALL ACREAGE PLANTING, fertilizer & compost spreading, disking, and rototilling. Call Jobs at 806-205-0270 for a free estimate. 11-ctc

ASSISTED LIVING HOME in Clarendon has available a very large private room (15' x 15') with private bath and large walk-in closet. All meals and care. Warm and safe environment. Twenty-three years worth of excellent references. Transportation to local appointments. Good food, good care, good company. 874-5000. State License #125054

REAL ESTATE

3 BEDROOM, 1 1/5 BATH, CARPORT: 710 South Allen. Newly remodeled. Call for appointment. 806-570-8869.

VICTORIAN STYLE TWO story house in Hedley for sale. Four bedroom 2 bath. Lots of trees on 1.5 acres. 125 SE 6th St. \$21,500. 806-662-1095

14 X 80 MANATEE MOBILE home. 1983 model in good condition. 3 bedroom , 1 3/4 bath, central heat & air, formal dining room, breakfast nook, new paint, new carpet, new tile, 17x22 den with 14 ft ceilings, and 30x30 garage under house. Located on 4 lots, with back garden house with single garage. Call 874-9392 or 336-9131 for more information.

NICE HOME FOR SALE in Howardwick. 2000 square feet, 3 bedroom, 2 bath, large den with fireplace, central heat & air, formal dining room, breakfast nook, new paint, new carpet, new tile, 17x22 den with 14 ft ceilings, and 30x30 garage under house. Located on 4 lots, with back garden house with single garage. Call 874-9392 or 336-9131 for more information.

Big E Classifieds On-Line
www.ClarendonLive.com

FOR SALE
702 S. Gorst • Clarendon
Blue house, one acre,
3 bedroom, 1 1/2 bath.
Super neat place!
Reduced to \$72,500.00
Call Cindy at 806-677-4461.

REAL ESTATE

Jim Garland Real Estate
806-874-3757
• Have buyers for ranches, farms, & recreational properties.

LINDA M. NAYLOR REAL ESTATE
Providing a Personal Touch!
Texas Licensed Real Estate Broker
License # 604414
Cell Phone: (806) 204-0005
403 N. Johnson St., Hedley, Texas 79237

Charming cabin in the woods 249 Palacio Dr., Howardwick, Texas. Two Bedrooms, one bath, mature landscape, fully furnished. Price: \$57,000.00.
Updated cottage 420 S. Clarendon, Texas Two bedrooms, one bath, attached one-car garage. Price: \$40,000.00
3603 CO Rd. 29 Giles, Texas 1888 sq.ft., 3 Bedrooms, 2 Baths, Deck, Two-car, carport, Workshop, Water well, and 1.27 acres. \$49,000.00
303 Adamson, Hedley, Texas Brick, 1877 sq.ft., 3 Bedrooms, 2 Baths, Attached garage, Carport, 6 lots, Water well, Two storage buildings, and Large deck. \$90,000.00
DRASTIC PRICE REDUCTION TO \$130,000.00 Amazing Home and 1 acre of land: 2158 sq. ft., 4 bedrooms, 2 & 1/2 Baths, finished basement, city water, city sewer, water well, mature landscaping.605 S. Orpe on 70 S.
Leased Lot #123 Howardwick Mobile Home 2040 sq. ft. 2 Bedroom, 2 Bath, Huge sun room, Two car metal shed, 1 Car carport, Storage building, Kitchen appliances included, Golf Cart included. Price \$50,000.00
502 E. Wood Stucco 1456 sq.ft. 3 Bedroom, 1 Bath, Detached garage, Carport. Price \$60,000.00
930 W. 5th Brick 1778 sq. ft., 3 Bedrooms, 2 Baths, Finished Basement - 4th Bedroom, Detached garage, Carport, 600 sq.ft. Apartment above garage. Price \$135,000.00
Home for Sale in Hedley: Brick home at 420 Railroad St. Sits on 4 Lots. 1900 Sq. Ft., 3/4 Bedrooms, 2 Baths, Two-car garage, Covered patio, Carport, Huge storage building, Fenced backyard, corner Lot. Price:\$74,500.00
702 E. Wood St: 1716 Sq.Ft., Corner Lot, 3 Bedrooms, 2 Baths, Basement, Carport. Bargain Price: \$65,000.00.

Charming Remodeled Two-story Home Corner lot at 521 1/2 Street. 2072 Sq.Ft., 3 Bedrooms, 2 Baths. Reasonably priced at \$68,000.00.
4000 sq. ft. building with a commercial overhead door in the back storage area Located on HWY 287 in the business district. \$69,900.00
Lot at 113 Walleye Howardwick, Texas. Price \$600.00
320 ACRES WITH HOME AND TWO WELLS HIGHWAY 70 SOUTH. Excellent perimeter and cross fences \$1550 PER ACRE. OWNER WILL SPLIT ACREAGE INTO SMALLER TRACTS UPON REQUEST.
Two Bedroom - 1 bath trailer on two lots appliances included in sale. Nice carport and cellar. 357 Walleye St., Howardwick, Texas. \$19,500.00.
COMING SOON: Newly built duplexes. Call for details
For Lease or Sale
Beautifully restored and totally renovated commercial office building. Brick with 1500 sq. ft. and a 750 sq. ft. basement New wiring, plumbing, wood floors, windows and central heat/air. Two bathrooms and one is a handicap accessible bathroom Several offices and a conference room. Handicap ramp READY TO MOVE IN AND SET UP YOUR BUSINESS. Owner will entertain reasonable offers. REDUCTION OF \$10,000.00 FROM \$175,000.00 TO \$165,000.00.
Brick house at 1112 West 8th in Clarendon. 2 bedroom, 1 bath. Detached garage with studio apartment, carport, fenced backyard.Needs some TLC. Price reduction \$40,000.
710 S. Goodnight: 3 Bedroom/2 Bath w/ garage apartment \$59,900.00

Pictures at lmmaylorrealestate.com

STATE & REGIONAL

TEXAS STATEWIDE CLASSIFIED ADVERTISING NETWORK
TexSCAN

TexSCAN Week of August 10, 2014 BUSINESS OPPORTUNITY

OWN YOUR OWN Medical alert company. Be the first and only distributor in your area. Unlimited \$ return. Small investment required. Call toll free, 1-844-225-1200.

\$2000 BONUS! Oil field drivers. High hourly and overtime. Class A-CDL/Tanker. 1-year driving experience. Home 1 week monthly. Paid travel, lodging. Relocation NOT necessary. 1-800-588-2689 www.ttransports.com

ATTENTION DRIVERS Be a name, not a number. \$\$\$ up to 50¢ cpm plus bonuses! 401K + family friendly. CDL-A required. 1-877-258-8782. www.ad-drivers.com

AVERITT EXPRESS New Pay Increase For Regional Drivers! 40¢ to 46¢ CPM + Fuel Bonus! Also, Post-Training Pay Increase for Students! (Depending on Domicile) Get Home EVERY Week + Excellent Benefits. CDL-A required. 1-888-602-7440 Apply @ AverittCareers.com EOE - Females, minorities, protected veterans, and individuals with disabilities are encouraged to apply.

DRIVER TRAINEES NEEDED NOW! Learn to drive for Werner Enterprises. Earn \$800 per week. No experience needed. Get your CDL and pre-hire now. 1-888-734-6710

DRIVERS SHORT HAUL and regional tractor/trailer jobs: start now! Top pay, paid holidays, paid vacations, guaranteed overtime, and great benefits. CDL-A. 1-877-261-2101 www.schill.com

OWNER OPERATORS/ Fleet Drivers 2800-3200 miles/week average. ALL miles paid. Home every 6-8 days. Fuel surcharge, paid plates, permits. 1-888-720-1565. DriveParkway.com

OTR DRIVERS TRUCKLOAD! PD Practical loaded and empty same. Good Dot rating. Get home, weekly pay. Class CDL-A 2 year's experience required. www.climateexpress.com 1-836-584-6073

PARTNERS IN EXCELLENCE OTR drivers, APU equipped, pre-pass, EZ-pass, passenger policy, 2012 and newer equipment. 100% NO touch. Butler Transport 1-800-528-7825; www.butlertransport.com

PAID CDL Training! No experience needed. Stevens Transport will sponsor the cost of your CDL training. Earn up to \$40K first year and \$70K third year. Excellent benefits. 1-888-726-4130. www.becomeadrivers.com EOE

WANT TO DRIVE a truck? No experience? Earn while you learn. Company sponsored CDL training. Full benefits. earn \$41,500-1st year. 1-877-697-9878

HELP WANTED

HEALTHCARE JOBS. Now hiring RN's, LPN's/LVN's, CNAs, Med Aides. \$2,000 bonus, free gas. Call AACO 1-800-656-4414 Ext. 52

SCHOOL TRAINING
AIRLINE CAREERS begin here. Become an Aviation Maintenance Technician. FAA approved training. Financial aid if qualified. Housing and job placement assistance. Call Aviation Institute of Maintenance. Dallas: 1-800-475-4102 or Houston: 1-800-743-1392

BECOME DIETARY Manager (average annual salary \$45,423) in eight months in online program offered by Tennessee College of Applied Technology Elizabethon. Details: www.tcatelizabethon.edu, 1-888-986-2368 or e-mail patricia.roark@tcatelizabethon.edu

REAL ESTATE

20 ACRES in West Texas \$15,900. Special offer, save \$2000. No qualifying, owner financing, great property, great deal! 1-800-343-9444. Landbrkr@gmail.com

30-70 ACRES. Southern Val Verde County. Hunting/recreational property. Good cover, deer, turkey, javalina, quail. Near Lake Amistad. Starting at \$162/down, \$285/month, 9%, 20-years. 1-800-876-9720. www.ranchenterprisesltd.com

TEXAS HILL COUNTRY. Reduced for quick sale. Private wooded homestead \$19,900. 18-hole golf course, lake, resort style pool, new clubhouse. Financing available. 1-877-886-7576

LOOKING TO SALE land? Reach over 2-million readers for one low price in the Texas Statewide Advertising Network. Contact this newspaper or call 1-800-749-4793 for more detail.

Run Your Ad In TexSCAN!
Statewide Ad \$550
290 Newspapers, 871,154 Circulation
North Region Only \$250
93 Newspapers, 297,505 Circulation
South Region Only \$250
97 Newspapers, 366,627 Circulation
West Region Only \$250
98 Newspapers, 205,950 Circulation

To Order: Call this Newspaper direct, or call Texas Press Service at 1-800-749-4793 Today!

LEGAL NOTICES
Your Window to Local Government

Need To Sell It?
Why not place an ad in the Big E Classifieds?
Call before 5 p.m. on Mondays to see your ad here!
874-2259

NOTICE: While most advertisers are reputable, we cannot guarantee products or services advertised. We urge readers to use caution and when in doubt, contact the Texas Attorney General at 1-800-621-0508 or the Federal Trade Commission at 1-877-FTC-HELP. The FTC web site is www.ftc.gov/bizop.
Extend your advertising reach with TexSCAN, your Statewide Classified Ad Network.

Extension: Center pivot does not always mean efficiency

VERNON – Identifying, but more importantly gaining adoption, of the most efficient irrigation systems is an important step in water conservation within agriculture, according to a recent study conducted by Texas A&M AgriLife Research.

The study by AgriLife Research, in partnership with the Texas Alliance for Water Conservation, determined that producers who were not using low energy precision application, or LEPA, sprinkler systems were leaving as much as \$100 per acre behind.

Dr. Nithya Rajan, AgriLife Research agronomist in Vernon, helped complete the study by looking at different types of irrigation systems for their application efficiency. A more efficient irrigation system allows a larger percentage of the applied water to reach the root zone and not be lost to soil evaporation or evaporation from plant surfaces.

The study is a part of the project "An Integrated Approach to Water Conservation for Agriculture in the Texas Southern High Plains," initiated through funding from the Texas Water Development Board in 2005.

Rick Kellison, project director of the Texas Alliance for Water Conservation, said the study was designed to help producers "put a dollar figure to using the most efficient irrigation systems, because over the years they had shifted away from the efficiency of LEPA."

This eight-year project led to the establishment of the Texas Alliance for Water Conservation Demonstration Project, which involves about 30 producers' fields in Hale and Floyd counties.

While about 75 percent of the Texas High Plains irrigated acres are under center pivot systems, these systems can be equipped with different types of emitters, Rajan said. These include mid-elevation spray application, known as MESA; low elevation spray application or LESA; and LEPA. She explained MESA systems use spray emitters positioned at around 4 feet above the ground or higher, and are popular for irrigating taller crops like corn. LESA systems have spray emitters generally located less than 4 feet above the ground, and are popular for irrigating shorter crops like cotton. LEPA systems use emitters in contact with the surface that allow water to flow directly onto the soil, and are generally used in conjunction with furrow dikes.

The primary objective of the Texas Alliance for Water Conservation project has been to identify cropping systems and practices in this region that use less irrigation water while maintaining farm profitability.

"Over time, producers have moved away from LEPA to the spray pattern or LESA," Kellison said. "We thought if we could put a dollar value on changing from the spray mode back to LEPA, that would help."

Kellison said in 2011, less than 2 inches of rain fell on the test fields; 2012, less than 8 inches; and 2013, about 10 inches.

"In all three years, the only difference on the field was the LEPA vs. LESA irrigation," he said. "We made more than \$100 per acre net revenue on the LEPA span over the LESA span."

Both systems applied the same amount of water, but the efficiency of application of the water is what

made the difference, Kellison said. LEPA provides a direct application of water and thus concentrates the water in a smaller area. This reduces surface evaporation.

"In years when the temperatures are high, along with high winds, you can move the water into the soil profile faster and deeper," he said.

Kellison said in all three years of the drought conditions, the LESA or spray application was needed to get the crop started, but the producer, Glen Schur, switched right back to the efficiency of LEPA for the remainder of the growing season.

Rajan said the impact of switching irrigation systems was demonstrated by setting up one of the eight spans in the center-pivot irrigation system as LESA, with the other seven being LEPA.

"All spans received the same amount of water, but cotton yields under the LESA span were substantially less than yields under the neighboring LEPA spans," she said.

Since LEPA is more efficient than LESA, more of the water supplied by the LEPA system reached the plants' roots, resulting in increased growth and yield.

Schur said in doing the experiment, "I found out there is more difference between LEPA and LESA than I thought."

He said for the past three years he has averaged 160 pounds of cotton lint difference using the same amount of water between the two systems. On a 120-acre pivot, that equals \$12,000.

"Not only is it a water conservation measure, but it makes the value of the water higher," Schur said. "There are always going to be certain things you have to run in broad-

cast spray, getting the crop up and incorporating chemicals, but then I find it a big benefit to switch and run it in LEPA.

"Some people are concerned that they need to cover all the area in water, but it is really more important to get the penetration of the water into the soil profile," he said.

Rajan explained that following an irrigation application water is predominantly lost through evaporation from the wet soil surface. This is called Phase I evaporation and occurs at the rate determined by potential evapotranspiration. Once the soil surface dries, water is lost from the soil by Phase II evaporation. Phase II evaporation is controlled by the diffusion of water vapor through the soil and is generally much less than Phase I evaporation.

The application efficiency of an irrigation system is related to its ability to place water in the root zone of the crop, she said.

"We investigated the emitted uniformity and application efficiency of 14 center pivot irrigation systems in the Texas High Plains," Rajan said. "Application efficiencies were in the range of 60-70 percent for MESA systems, 70-80 percent for LESA systems and greater than 90 percent for LEPA systems."



ACE

PEST CONTROL

"Is your place an ace place?"

Terry & Jason Wheeler, C.A. TPCL 10615
www.acepestcontrol.pro
806-372-5449
ace.pest@yahoo.com

We Specialize in General Pest, Termite, Pretreatments

TERMITE SEASON FAST APPROACHING. CALL US FOR INSPECTIONS.

Morrow Drilling & Service

Hwy. 287 West, Clarendon

Water Well Specialist • Turnkey Systems
Solar Windmill • Electric Irrigation
30 Years Experience

John E. Morrow (806)874-2704 • (806)662-3943

GLASSTECH

WINDSHIELD REPAIR

Larry & Donna Hicks

Call Donna at
806-874-3108 • 806-205-1501

SEAL THAT CHIP BEFORE IT SPLITS!

4-M

DRILLING

IRRIGATION, DOMESTIC, TEST HOLE
GOULDS AND SIMMONS PUMPS

JOE MORROW, OWNER
P.O. Box 701 CLAUDE, TX 79019 806.226.5023 806.681.7150

Subscribe Today. 874-2259.

Mr. Fix It

Kyle Hill

Minor repairs, odd jobs, and more.

672-8908

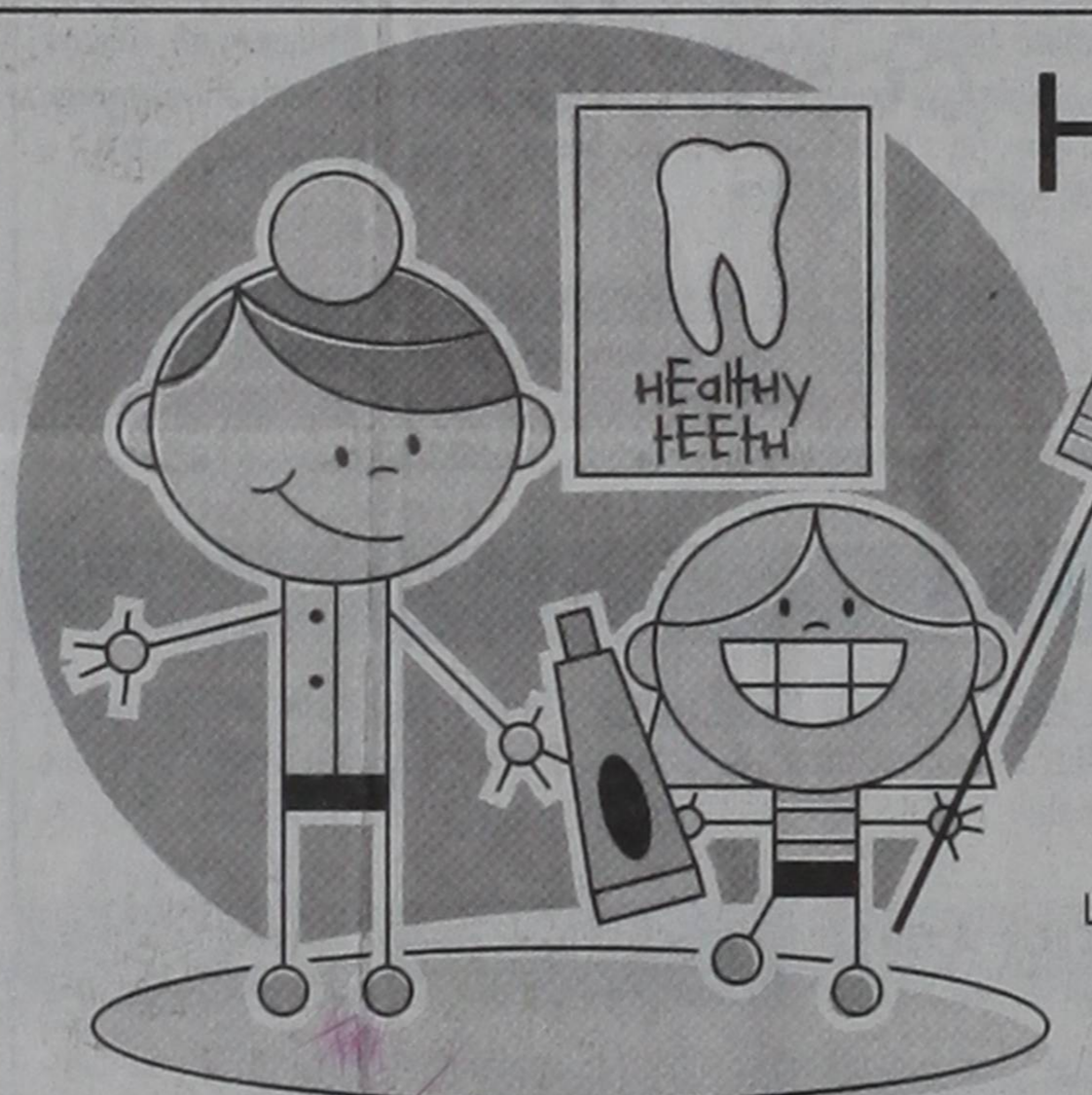

Head back to the dentist before you head back to school!

Make a dental check up part of your child's back-to-school routine!

- Family Dentistry
- Orthodontics
- Implants
- Bleaching

Richard Sheppard, DDS

Located in the Community Services Building, Medical Center Campus in Clarendon

Now listed in the White Pages!
806-874-5628



Nita Massey, LNFA
Administrator

Memphis Convalescent Center

(806) 259-3566 Phone 1415 N. 18th Street
(806) 259-5098 Fax Memphis, Texas 79245
(806) 205-2442 Cell www.memphisconvalescent.com
Nita_Massey@csnhc.com

LET THE ADVENTURE BEGIN!

Check out WonderlandPark.com for more details

WOW THEM at Wonderland!



f t

Start on the Path to a New Career



VN & ADN NURSING

COSMETOLOGY & NAIL TECH

RANCH & FEEDLOT OPERATIONS

HEATING & AIR CONDITIONING

WIND ENERGY

WELDING



Career and Technical Education





Clarendon

COLLEGE

Unleash your potential!

Call us today! • 800.687.9737

Locations in Clarendon, Pampa, Childress & Amarillo

www.ClarendonCollege.edu