



# THE CLARENDON ★ Enterprise

CAR-RT LOT\*\*B 006 EXPIRES 5/15  
CLARENDON SCHOOL LIBRARY  
PO BOX 610  
CLARENDON TX 79226-0610

06.26.2014

The Texas Panhandle's First Newspaper.  
Established 1878.

THE CLARENDON NEWS & THE DONLEY COUNTY LEADER

www.ClarendonLive.com

Single **\$1.00**  
Copy

### THIS WEEK

- 2 Fred takes on the NSA and stands up for American freedom.
  - 4 Bob Watson is back with new scams targeting homeowners.
  - 6 Check out who we spotted playing machine-pitch at Hart-Moore Field Saturday.
  - 8 And the Lady Bulldogs welcome a new coach.
- All this and much more as *The Enterprise* reports in this week's amazing edition!

### Straus taps King for workforce group

Texas House Speaker Joe Straus announced last week that he has appointed Representative Ken King (R-Canadian) to the Joint Interim Committee to Study Education Policy for a Skilled Workforce.

This committee will study how career and technology education (CTE) programs can better align with those offered in Texas colleges and with the needs of Texas employers.

"There are many jobs that do not require a college degree but do require some post high school education and training. Currently the United States lags behind other countries in linking postsecondary education with the needs of the labor market. In order for Texas to close this gap, it is necessary to explore opportunities for education and workforce partnerships," Representative King said.

"I am honored that Speaker Straus has given me the opportunity to serve on this committee," King said.

Representative King served on the House Public Education Committee during the 83rd Session.

### County reminds car buyers of option

Donley County Tax Assessor / Collector Linda Crump is reminding residents that when they purchase a new or used vehicle out of county that they can still register their vehicle in Donley County and keep those tax dollars at home.

Write "Donley County" on the county of issuance Form 136 to have your title and registration here. Each title that is issued for a motor vehicle brings the county a portion of the sales taxes and at least \$66.17 of the title and registration fee.

Crump said some auto dealers may tell you that they have to do the title work in their county or that Donley County will automatically receive the revenue, but both of those are wrong. Only the county of issuance receives the tax, title, and registration.

### CHS Class of 1984 to reunite July 4th

The Clarendon High School Class of 1984 will gather at the square on July 4 during the barbecue to celebrate their 30th reunion. Bring your lawn chairs, stories, and family.

Contact Kristen Walker Musser if you have any questions via email at: kmusser501@gmail.com

## Local church to celebrate centennial

The Clarendon Church of Christ will celebrate its 100th anniversary this Sunday with a special service.

Members of the Church of Christ began worshipping in 1914 in Clarendon, Texas. The small number grew to 14 members in 1917 and worshipped in the T.M. Little home at the end of Carhart Street. This same year the group purchased a small wooden building near the pres-

ent post office site. Members at that time were: Mr. & Mrs. T.M. Little, Mrs. Emma Little Saye, Mr. & Mrs. McGowan, Mr. Cooper, Mrs. Moffitt, Mr. & Mrs. Reed, Mr. & Mrs. John Watters, Mr. & Mrs. U.T. Dever, and Mr. M.F. Roberson. Dee Smith and family later joined the group. G.W. Brewer was the first known minister in 1920.

A storm demolished the church building and the congregation was

allowed to worship in the court house until a building was constructed at 3rd Street & Carhart Street. More land was purchased throughout the years by the elders and the present building was constructed. The elders continued to purchase land and built a nice family center across the street.

The present congregation is very active in teaching through the World Bible School and in helping the Navajo nation teach their people

the Bible.

The present minister is Christ Moore. Elders are Donald White, Gene Denney, William Thompson and Carol Duncan. Deacons serving at this time are Earl Shields, Jim Stevenson, Jackie Bell, Audie Watson, Bob Watson, Carlton Turvaville, and David McAnear.

The congregation invites all friends and past members to attend a special Homecoming celebra-

tion Sunday, June 29, 2014, at 9:30 a.m. Tom Harguess, the local minister from July 1980 to the summer of 1983, will deliver the sermon. A delicious meal will be provided for all guests following the morning service.

Pick up next week's Pioneer Edition of THE DONLEY COUNTY LEADER inside the ENTERPRISE for more history of the Clarendon Church of Christ.



### Fire!

Clarendon's Steve Sell fires off a shot during the benefit shooting for the Howardwick Baptist Church last weekend. Winners of the event were Small Caliber Division - Sell, first; Jesse James, second; and Wayne Cole, third; Large Caliber Division - Randy Stubblefield, first; Kelly Hill, second; and Sell, third; and Youngest Shooter, Ashley James of Wheeler.

COURTESY PHOTO / SIS JAMES

## Enterprise receives recognition

The Clarendon Enterprise placed second in the hunt for top honors during the 2013 Better Newspaper Contest hosted by the Texas Press Association.

Contest winners were announced last Saturday during the TPA Summer Convention in Corpus Christi, and the Enterprise finished behind The Red Oak Record for the Division 10 Sweepstakes Award.

The Enterprise received a first place plaque for General Excellence and second place honors for Column Writing and for Advertising with ad for Country Bloomers, the Chance Mark Jones 5K, and the Mulkey Block Party.

Sports Photos by Roger Estlack and Kari Lindsey received third place, and the ENTERPRISE received fourth place honors for Editorials and News Photos.

This year 159 newspapers submitted 1,566 entries in the contest. The contest is broken down into 10 divisions in which newspapers compete against papers of similar circulation size.

## CC Regents travel to Pampa for June meeting

Clarendon College Regents took their show on the road last Thursday, June 19, holding their regular board meeting in Pampa.

Several Gray County dignitaries were on hand for the meeting, including County Judge Richard Peet, Pampa ISD Board President Lee Porter, Pampa ISD Superintendent David Young, and members of the Clarendon College Pampa Center Foundation.

Going through their agenda,

Regents approved a \$60 per hour flat rate tuition for courses offered in the Texas Department of Criminal Justice unit in Pampa. CC will be offering classes there this summer during the next academic year.

The board approved a purchase of a welding simulator from Lincoln Electric in Lubbock for \$24,000. The simulator consists of a welding mask with a 3D display inside so that the student "sees" an image of what they are working on.

The board acknowledged the resignations of Annette Ferguson, Raymond Jaramillo, Aaron Lopez, and Raquel Hawkins and approved the new hires of Kelly McDonough and Cannon Roberts to teach English and Catheryn Bailey as an RN instructor.

The board also acknowledged the reassignment of Becky Green as the Associate Dean of Enrollment Services to coordinate admissions, recruiting, testing, and financial aid

in an effort to streamline the enrollment process for students. Green will work under Vice President of Student Services Tex Buckhaults.

David Hall was also reassigned as the college's Associate Dean of Career, Technical, and Continuing Education under the Vice President of Instruction, Dr. Roger Schustereit.

Regents approved updated signature cards at Herring Bank and the National Bank of Commerce to include Buckhaults, Schustereit,

and Alice Cobb and updating the college's investment committee to include Dr. Robert Riza, Alice Cobb, and Ashlee Estlack.

In his president's report, Riza said CC is in discussions with Amarillo ISD to offer cosmetology classes for dual credit in four high schools in Amarillo.

Riza also updated the board on the college's new Registered Nursing program, which started this week with 20 students.

## CC launches RN program

The first LVN to ADN bridge cohort at Clarendon College started classes Monday morning in Pampa. Dr. Robert Riza, president of CC, welcomed the students and shared his excitement about this being the first class in the new ADN program at CC.

Twenty students from all around the Panhandle make up this first cohort. After successful completion of their courses next summer, these students will sit for the RN exam.

A traditional ADN - Associate Degree in Nursing - cohort will start in the fall. For more information, interested students are asked to call Jackie Sublett in the Nursing Department at 806-665-8801.



Clarendon College's first class of students working on their Associate of Nursing Degree

CC PHOTO / ASHLEE ESTLACK

## New Location, New Name, Same Great Prices!

**Wednesday, June 25 - Friday, July 4**  
East of Clarendon on 287  
Operated by Nathan & Tamra Floyd • 806-336-1166

ENTERPRISE STAFF

Roger A. Estlack
Publisher & Editor

Ashlee Estlack
Contributing Editor

Tara Hogan
Office Director

Morgan Wheatly
Ads & Layouts

CORRESPONDENTS

Peggy Cockerham
Howardwick

Sandy Anderberg
Clarendon Sports

Fred Gray
College & Hedley Sports

Kari Lindsey
Photographer

Matthew Martinez
Photographer

Kathy Spier
Hedley

CONTACT INFORMATION

Phone
806.874.2259

Fax
806.874.2423

E-Mail
news@clarendononline.com

Web Site
www.ClarendonLive.com

ADVERTISING

Open Display rates are \$5 per PASS column inch. Classified Ads are \$10 for the first 15 words and 15¢ per word for each additional word (Boxes or special typography are extra). Thank You Notes are \$15 for the first 40 words and 15¢ per word for each additional word. Basic engagement, wedding, anniversary, and birth announcements are \$10 each. Expanded wedding announcements are \$20. A one-column announcement picture is \$5, and a two-column announcement picture is \$10. Pictures submitted for publication should be picked up within ten days after publication. Basic death notices are printed at no charge. Full obituaries are published for \$45 or \$50 with a photo.

DEADLINES

News articles and photos are due by Monday at noon. Advertising and Classifieds are due by five o'clock Monday afternoon. Deadlines may be altered for holidays or special issues.

SUBSCRIPTIONS

Annual subscriptions are available for \$30 for zip codes inside Donley County, \$40 elsewhere in Texas, and \$45 out of state. POSTMASTER: Send all address changes to: The Clarendon Enterprise, PO Box 1110, Clarendon, TX 79226-1110. Digital Subscriptions are \$15 per year.

LETTERS

Letters to the editor are welcome. Views expressed in letters are those of the writers and do not necessarily reflect the views of the editor or staff of The Clarendon Enterprise. Submission of a letter does not guarantee publication. Letters may be edited for grammar, style, or length. All letters must be signed and must include an address and telephone number for verification. To improve your chances of publication, type and double space your letter, stick to one main topic, and keep it brief. No letters will be accepted from candidates for local political offices. Letters submitted to this newspaper become the property of The Enterprise and cannot be returned.

The Texas Panhandle's First Newspaper

THE CLARENDON NEWS, established June 1, 1878 with which have merged: The Clarendon Traveler, February 1889; The Clarendon Journal, November 1891; The Banner-Stockman, October 1893; The Agitator, February 1899; The Clarendon Times, May 1908; The Donley County Leader, March 12, 1929; The Clarendon Press, May 18, 1972; and The Clarendon Enterprise, March 14, 1996.

Member 2014



National Newspaper Association



Texas Press Association



West Texas Press Association



Panhandle Press Association



Observations, Thoughts, and Scatter Shots

Honest-to-goodness columnists who write scatter-shooting accounts on miscellaneous topics often refer to such pieces as "potpourri." This has always impressed me, since my using the word always requires a visit to Webster or Google—my predictable response to a Spell Check squiggle.

I usually call it a "Mother Hubbard" column, which, like the frontier dress so named, covers everything but touches nothing.

That's the current intent, with thoughts and observations all over the map, some of them original.

\*\*\*\*\*

Here's a friendly warning to editors who may have just arrived at rural newspapers.

This is the time of year farmers bring in pictures of produce on hormones. They'll brag that the trophy-sized cucumbers/squash/watermelons/gourds are the biggest ever grown in the county.

Run a picture claiming same, and do so at your peril. As surely as you do, expect another farmer next week to bring in identical produce, only larger. And the growing season still has a couple of months to run.

\*\*\*\*\*

Instant racing (sometimes called historical racing) allows participants to bet on horse and dog races already run—some kind of video/automated/coin-operated deal.

How far along would red-nosed and fuzzy-minded gamblers need to be to fall for such a set-up?

My guess? Imbibers would be several drinks beyond amiable incandescence.

\*\*\*\*\*

Kids are off to church camps this summer, and they come home with new songs, stories and table grace ditties.

One brought smiles repeating a mealtime prayer heard at a table of, uh, teen campers.

"Bless this meat. Leave the skin. Back your ears, and dive right in..."

\*\*\*\*\*

One of our two rescue dogs, a red Dachshund, is a licker extraordinaire.

Sadie, mostly Jack Russell, ignores toes. She's far more interested in sniffing the hands that feed her.

A visiting grandchild, giggling as her toes were licked by multiple licks, was intrigued, but asked if she has a "licker" license.

\*\*\*\*\*

Not much is heard these days about the "Wrestlers' Birthright."

They had a reunion recently, however, calling it a "mer-versary."

Reminds me of the sports editor who apologized for running the wrong wrestling results in the newspaper. "The ones that ran in today's paper are actually next week's results," he claimed.

\*\*\*\*\*

Selected short subjects include:

If Los Angeles Clippers' owner Donald Sterling were a haircutter, it would be a bad one.

Miami Heat's King James should either be deposed or reduced in rank to Prince James.

Jordan Goldberg: "Can't buy charisma. If one could, Mitt Romney would have bought a pallet of it at Costco and probably be president now."

Since Texas' STAAR results are coming in negative, maybe we should aim a bit lower, say with "MOOOON" tests.

Since competitive cheerleading is in line for UIL recognition, think how many additional coaches will be available to fire.

Tolling bells are now running a distant second to tolling roadways.

Teacher, weakened by a rough school year, offers cartoon description: "On the highway of life, I'm the one in orange picking up trash."

Tough fourth grade teacher, facing new crop of math students, stares 'em down, saying, "Each of you looks like a ball lost in the tall weeds."

Johnny Football signs a baseball contract with San Diego Padres? This'll be the closest he ever gets to priesthood.

A bulging list growing daily—the number of pipers who must be paid.

A household divided against itself may have a hard time getting foundation insurance coverage.

It's no longer a "pay as you go" world. It's pay "as you hope to go"...

Ha! We had colored phones in the 50s. They returned to black, however, when Momma took one sip with a wet dishrag at the misplaced marmalade.

I know a guy who goes backward, he eats broccoli from the wrong end.

When some VA officials speak of "core" values, it sounds like a description of what they are rotten to....

In which ever lines you find yourself in today, hope fully there are no life or death issues involved—unless you're at a VA hospital.

\*\*\*\*\*

Let us close this time with quote from St. Augustine of Hippo (354-430 AD).

This early Christian theologian/philosopher wrote: "Faith is to believe what you do not see; the reward of this faith is to see what you believe."

\*\*\*\*\*

Dr. Newbury is a speaker in the Dallas/Fort Worth Metroplex. Inquiries/comments to: newbury@speakerdoc.com. Phone: 817-447-3872. Web site: www.speakerdoc.com. Twitter: @donewbury

NSA spying on Americans must cease

Finally, our inept Congress has done a little something to reign-in the outrageous spying on Americans by the NSA. Granted, it wasn't much, but at least it was a start. We need to insure that it continues.

Last Thursday night, the US House of Representatives voted 293 - 123 to pass an amendment to a Department of Defense appropriations bill that would cut off all funds for two of the agency's most insidious activities: Firstly, using the myriad provisions of the Foreign Service Intelligence Surveillance Act to perform searches of the mass communications data that is collected from all Americans, and secondly, asking hardware manufacturers and software developers to install backdoors into their products designed to give the agency access to their users' communications. On that second item, the amendment specifically forbids funding for any agency attempt "to mandate or request that a person or company redesign its product or service to facilitate electronic surveillance."

This amendment represents a response against the nefarious behavior revealed from the leaks of Edward Snowden, which have shown that the NSA subverted cryptography standards, redirected hardware shipments to plant NSA bugs in products, and created other ways to gather raw, bulk communication data from companies like Google, Facebook, AT&T, Microsoft, Apple, ad nauseam. These companies, unfortunately, are not our friends. They knowingly cooperate with the NSA.

Of course, this amendment and bill must pass the senate (home of our Texas Senator from Canada, eh) if anything is to be done. Hopefully, the House vote sends a message that there is now the political will to do something about the abusive spying on Americans by the NSA. The point is that these spying programs need money in order to survive, and we can cut off that funding if they continue their dastardly ways.

The bill also represents a remarkable shift from the useless Freedom bill, intended to curb NSA mass surveillance, which passed the House last month in a paltry effort that disappointed privacy adherents. The members of the house only paid lip service to the American people, and passed a Freedom bill that was an absolute joke. Actually, the contrast between the Freedom bill and this bill is a result of political procedure: Most of the weakening of the original Freedom bill occurred in the Judiciary and Intelligence committees. However, as an amendment to an appropriations bill, last week's defunding legislation was able to escape the intense lobbying that was present in the aforementioned committees. It did not have to go through the Intelligence Committee, which is basically a puppet of the intelligence community.

Actually, that powerless surveillance reform bill may have inspired Thursday night's vote by not going far enough to please House members seeking to curtail the NSA's spying on Americans. Due to the diluting of that bill's anti-spying provisions in committee, many House members never had the opportunity to show their wish to drastically limit the NSA's overzealous spying activities. So, what does this all really mean? Even if the amendment actually becomes law, which is iffy at best, it still wouldn't end all federally mandated backdoors in hardware and software. For example, it will have no effect of the FBI, which drastically limits its effectiveness. However, the passage of the amendment still signals a welcome

shift in the political landscape, thanks primarily to Snowden's spying disclosures. Last year, for example, a similar amendment was put to the vote and it fell seven votes short of passing. The lopsided vote this year illustrates that reigning in the NSA has become a popular political cause that crosses party lines. There is now a sense, at least in the House, that if you're not doing something about this issue, it could result in unpleasant political repercussions, like losing your seat.

Now, it is up to the Senate to pass similar legislation. If they don't act satisfactorily on this legislation, then we need to hold them accountable by voting them out of office. In the immortal words of Ben Franklin, "Those who are willing to sacrifice liberty for security deserve neither." I'm not willing to benignly accept a situation in which the federal government is allowed to listen to all my phone conversations, read my emails, or view my other internet communications, whatever the form they may take.

Who knows, perhaps someday I may have a brilliant thought. If so, I would like to keep ownership of it. Or, perhaps an ex-wife or two decides to mistakenly take me to task for some obviously exaggerated transgression that I may have committed in the past. If so, I don't want the government or anyone else to shed undue light on it. In short, I want my personal life kept personal. Perhaps even more importantly, I want the personal lives of others to also be kept personal.

Meanwhile, we all owe Edward Snowden a healthy portion of gratitude. His revealing the reality of the spying on Americans by our own government can only make our democracy stronger. After all, over the years, many Americans have given their lives defending our liberty and freedom. Let's do all we can to make sure their sacrifices were not in vain.



the quick, the dead, & fred by fred gray

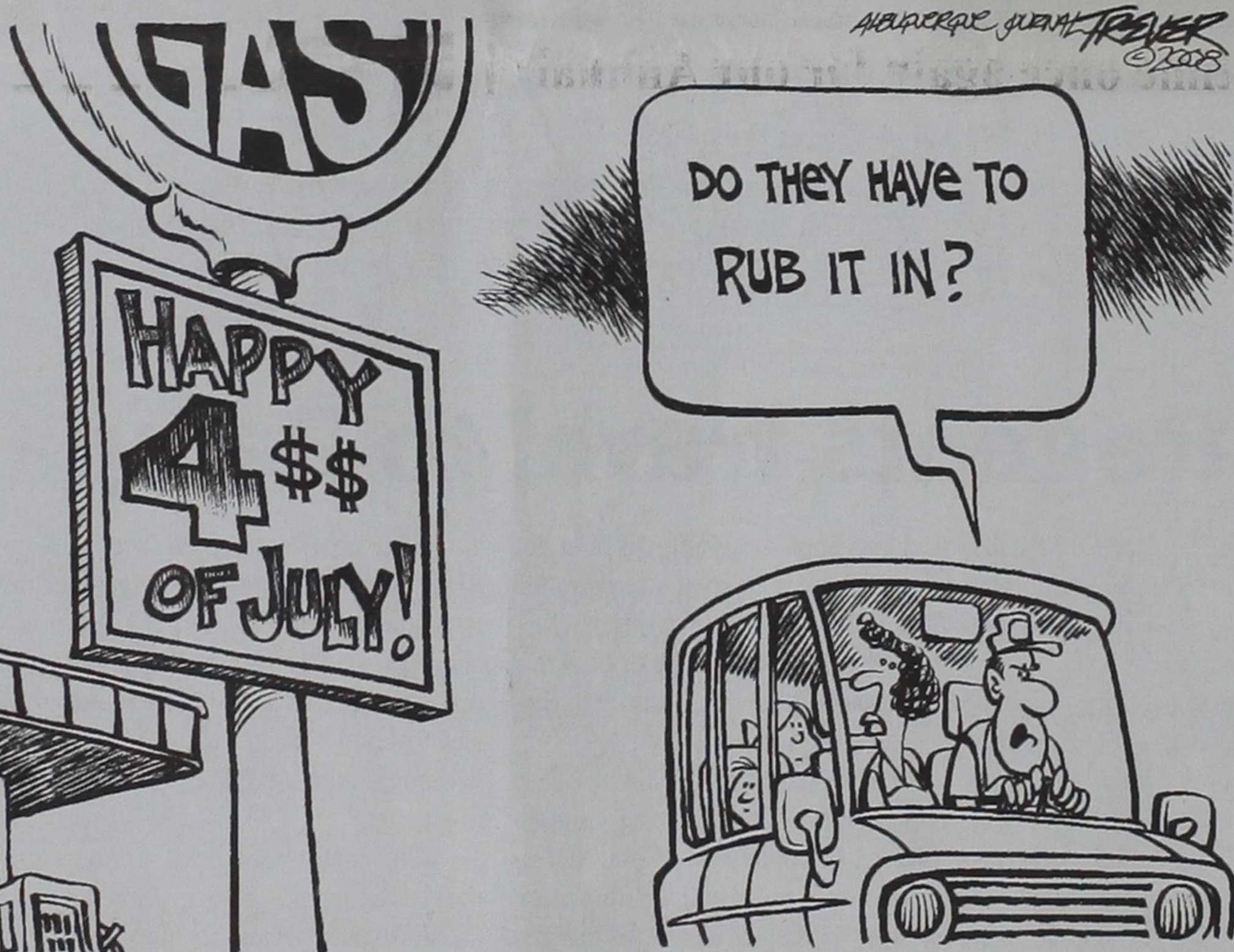

Five things to fix the border crisis

Over the past several months, tens of thousands of unaccompanied minors -- almost all of them from Honduras, Guatemala, El Salvador, or Mexico -- have been detained at our southern border while crossing illegally into the United States. A large percentage have been found in the Rio Grande Valley region of South Texas.

Sadly, this ongoing humanitarian crisis is very much a man-made crisis. More specifically, it is a direct result of President Obama's misguided immigration policies.

Two years ago, the president stood in the Rose Garden and announced a unilateral change to US immigration policy regarding children. Between that policy change and his broader refusal to uphold our immigration laws, he created a powerful incentive for children to cross into the United States illegally.

Don't just take my word for it. "There is growing evidence," reports the Washington Post, "that a surge of tens of thousands of Central American minors across the Mexican border into Texas is being driven in large part by the perception they will be allowed to stay under the Obama administration's immigration policies."

Consider the numbers. In fiscal year 2011, roughly 6,560 unaccompanied alien children were apprehended at the US-Mexico border. That figure grew to nearly 25,000 in 2013, a year after the President's Rose Garden Speech, and

US officials estimate that it could reach 90,000 in 2014, before surging to 142,000 (or higher) in 2015.

In other words, policies that were supposedly adopted for humanitarian reasons have produced a humanitarian disaster.

Make no mistake: The migration journey from southern Mexico to the Rio Grande is among the most treacherous in the world. In his 2013 book, "The Beast," Salvadoran writer Oscar Martinez documents the horrific violence that is routinely inflicted on migrants by drug traffickers, gang members, and human smugglers. The risks to women are especially harrowing: Experts believe that at least six out of every ten female migrants become victims of sexual assault.

Indeed, migrant women are preyed upon by ruthless Mexican drug cartels such as the Zetas. For example, an official from the mayor's office in Ciudad Hidalgo (a Mexican city along the Guatemalan border) told Martinez that "in Ciudad Hidalgo the Zetas control all trafficking, sending men to recruit women in Central America and sometimes even kidnapping migrant women riding the buses. They sell the

women to truck drivers for a night and then throw them away like unwanted scraps."

There is nothing "humane" about encouraging people to travel through cartel-dominated smuggling routes in hopes of reaching the United States. Yet that has been the effect of President Obama's policies.

I therefore call on the president to immediately do five things:

First, he should publicly (and repeatedly) declare that the so-called deferred-action programs he announced in June 2012 will not apply to the children currently arriving at the border.

Second, he should publicly (and repeatedly) discourage people in Central America and elsewhere from sending their children on such a dangerous journey through Mexico.

Third, he should start enforcing all US immigration laws, not simply the ones he finds politically convenient.

Fourth, he should make sure that Texas and other US border states have the resources they need to handle the migrant influx.

Fifth, he should work with Mexican officials to improve security at their border with Guatemala, which most of these children appear to be crossing.

If the president took all those steps, not only would it help us resolve the current crisis, it would also help prevent a similar crisis from erupting in the future.



texas times by sen. john corry

## Celebration starts next week

The 137th annual Saints' Roost Celebration will be held July 3, 4 and 5 this year.

### July 3

Downtown merchant sales and a Depression Lunch from 11 a.m. to 1:30 p.m. will start the celebration on Thursday, July 3.

The Clarendon Lions Club will dedicate and cut the ribbon on the new Chance Mark Jones Memorial Playground in Prospect Park at 11:30 a.m.

The Clarendon Outdoor Entertainment Association will hold its Junior Ranch Rodeo that evening beginning at 7 p.m. with a dance to follow. Kids events will precede all three nights of rodeo with mutton bustin', calf rides, steer rides, and donkey rides.

### July 4

The bulk of this year's activities will take place on Friday, July 4, with the Craft Fair starting at 9 a.m. on the Courthouse Square. The Craft Fair is

sponsored by the Donley County 4H, and booth space is \$25. Booth space needs to be reserved by June 27 by calling 874-2141.

Also on the square July Fourth will be the Old Settler's Reunion and Kids' Tricycle and Bicycle Parade both starting at 10 a.m.

The kids' parade will line up at Keith Floyd's shop at Third and Sully.

The CHS Class of 1984 will be holding their 30th reunion during the celebration and enjoying barbecue together on the square.

Ed Montana will be handling the parade and celebration announcing and will also be performing live music during the festivities on the square.

The Shriners' Barbecue begins at 11 a.m. Tickets are on sale now at the Enterprise for \$10 each.

The Western Parade will begin at 2 p.m. with the Lions Club Cow Patty Bingo to follow.

The COEA's Ranch Rodeo

will be held on Friday and Saturday, July 4 and 5, at 7:30 p.m. with No Dry Country providing dance music on Friday, and the Matt Martindale Band playing on Saturday.

Box seating tickets are still available for all three nights of rodeo for \$150. Contact Theresa Shelton for 654-2993 for information.

### July 5

The annual Henson's Turtle Race will be held on 3 p.m. on Saturday, and plans are in the works to introduce an adult division for the more experienced turtle jockeys. There is no charge to enter the kids' race, but organizers are planning to have entry fees for adults, with the winner getting half the pot and also getting a choice of charities for the remaining money.

More celebration details will be printed as they become available. To add your event or activity to this listing, contact the Enterprise at 874-2259.



Hedley 2014 graduates, Kristen Liner, Bailey Wood, and Kyle Lindsey recently participated in MASH camp, sponsored by Panhandle AHEC/WTAMU. Medical Avenues to Services in Health (M\*A\*S\*H) programs are designed to educate High School students about the possibility of pursuing a career in the health service field after they complete their education. M\*A\*S\*H programs are highly interactive, informative and fun.

COURTESY PHOTO / AHEC/WTAMU

### 4H Rafting Riding Lawn Mower

Members of the Donley County 4-H are helping out the Donley County Activity Center by selling chances at a new John Deere riding lawn mower to be given away during the COEA's Ranch Rodeo on July 5. Proceeds are used to help pay the note on the building.

Chances are \$5 each or a book of five for \$20. Contact your favorite 4-H member to purchase tickets or find them on the square during the 4th of July Craft Fair.

OUTPOST PHARMACY  
WELLNESS CENTER

"Everything under one roof!"

# THE CLARENDON OUTPOST

US 287 WEST • CLARENDON, TEXAS

CALL: 874-5201 • OPEN DAILY 6 A.M. TO 10 P.M. • PHARMACY: 874-5202

AD GOOD THRU: July 3, 2014

## BUY ONE GET ONE FREE

IBUPROFEN

BOGO COUPON

NOW \$4<sup>99</sup>

TUSSIN DM

BOGO COUPON

NOW \$2<sup>99</sup>

NAPROXEN

BOGO COUPON

NOW \$3<sup>99</sup>

MIGRAINE RELIEF

BOGO COUPON

NOW \$3<sup>49</sup>

ASPIRIN

BOGO COUPON

NOW \$1<sup>79</sup>

## NEW MERCHANDISE



PURSES & WALLETS

Western • Bling • Floral • Vintage • A Style for Everyone

## METAL SIGNS

Vintage • Coca Cola • Super Hero • Cars • Betty Boop • I Love Lucy • John Wayne



HOT PLATE

God Bless Texas hot plates

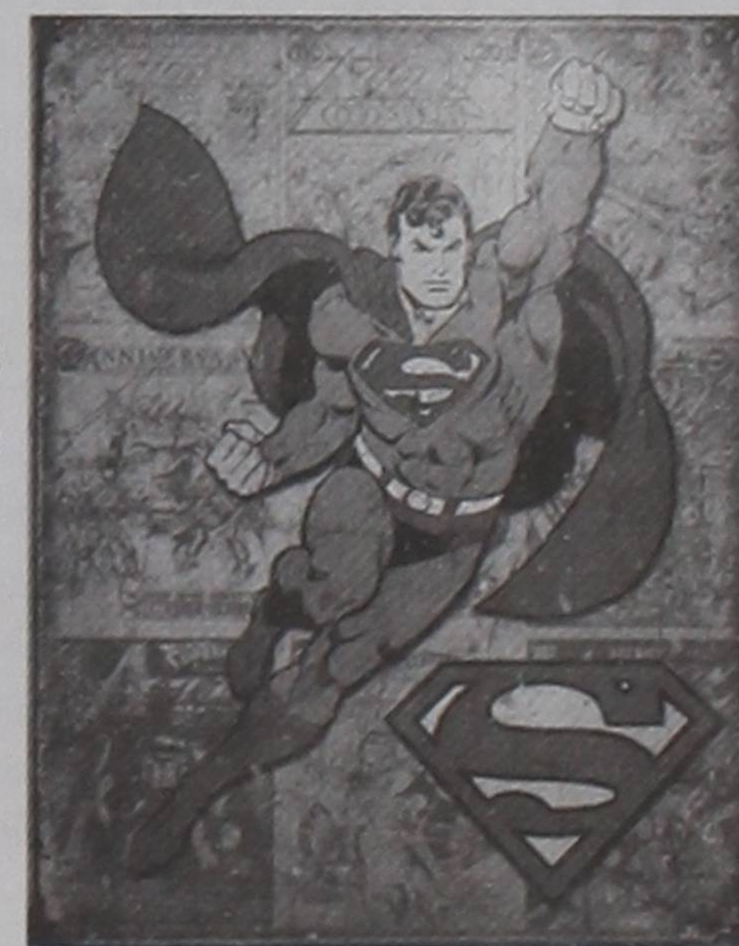

Get online. Get some information. [www.ClarendonLive.com](http://www.ClarendonLive.com)

**LOW BUCK STORAGE**  
822-0442

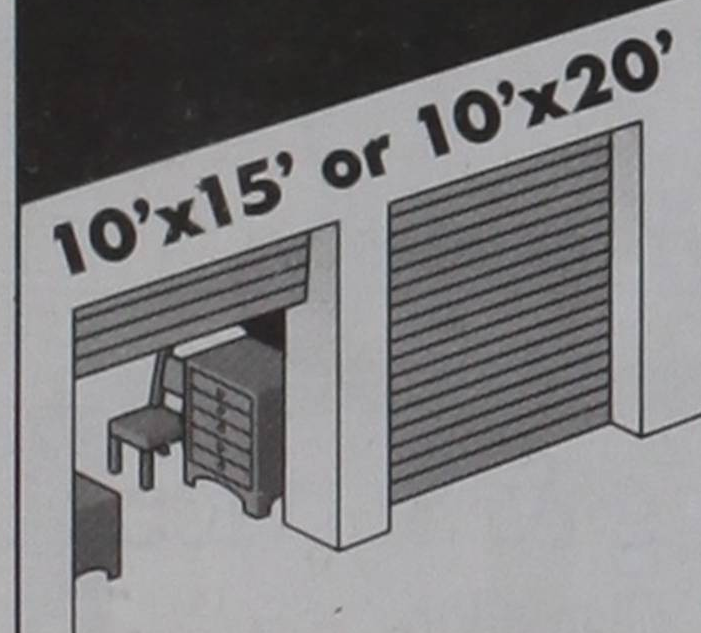

It's time once again for our Annual Fireworks Stand Fundraiser.

June 24<sup>th</sup> - July 4<sup>th</sup>

LARGE NEW ITEMS!

Come out and get your fireworks from us and help other causes at the same time!

Jesus Name Apostolic Church

Come See Us On Hwy. 70 North Across from Sandell Drive-In

Have a safe & happy 4th of July! God Bless!

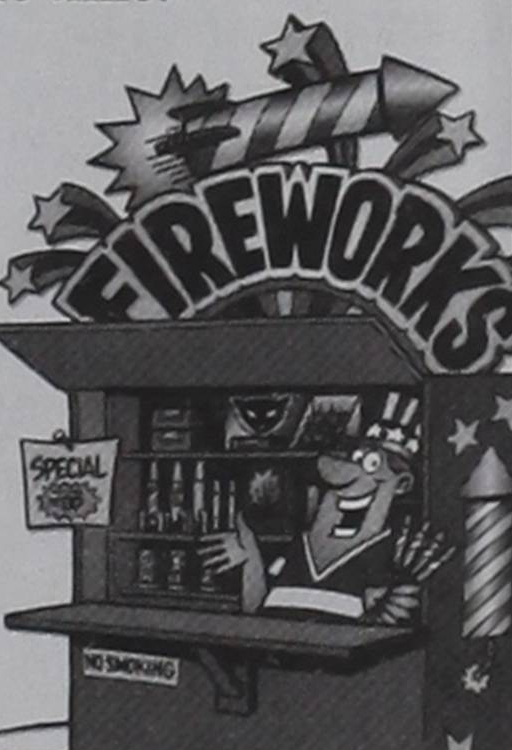

### NOTICE OF RATE CHANGE REQUEST

Southwestern Electric Power Company (SWEPCO or Company) publishes this notice that on May 7, 2014, it filed its Statement of Intent and Application for Authority to Implement a Transmission Cost Recovery Factor (TCRF) with the Public Utility Commission of Texas (PUCT or the Commission) in Docket No. 42448. The filing was made in accordance with the Public Utility Regulatory Act (PURA) § 36.209 and Commission Substantive Rule 25.239. The TCRF will recover SWEPCO's reasonable and necessary costs for transmission infrastructure improvements, as well as changes in wholesale transmission charges under a tariff approved by the Federal Energy Regulatory Commission (FERC). In this application, the time period for SWEPCO's transmission capital investments, to be recovered through the TCRF, is December 31, 2011 through February 28, 2014. SWEPCO also seeks to recover through the TCRF approved transmission charges that are not otherwise being recovered through current rates.

This notice is being published in accordance with PURA § 36.103 and Commission Procedural Rule 22.51(a)(1).

### STATEMENT OF INTENT TO CHANGE RATES

SWEPCO requests that the Commission approve a TCRF that would result in an increase in revenues of \$14,729,466 per annum, an increase of 5.01 percent in overall annualized revenue. SWEPCO has proposed that its requested rate change become effective 35 days after the filing of the Statement of Intent and Application. The proposed effective date is subject to suspension and extension by actions that may be taken by the Commission.

All customers in SWEPCO's Texas retail rate classes will be affected by this change. The impact of the rate change on various customer classes will vary from the overall impact described in this notice.

### CONTACT INFORMATION

Persons with questions or who want more information on SWEPCO's Statement of Intent and Application may contact SWEPCO at 428 Travis Street, Shreveport, Louisiana 71101, or call toll-free at (888) 216-3523 during normal business hours. A complete copy of the Statement of Intent and Application and related filings is available for inspection at the address listed in the previous sentence.

The Commission has assigned Docket No. 42448 to this proceeding. Persons who wish to intervene in or comment upon these proceedings should notify the Commission as soon as possible, as an intervention deadline will be imposed. A request to intervene or for further information should be mailed to the Public Utility Commission of Texas, P.O. Box 13326, Austin, Texas 78711-3326. Further information may also be obtained by calling the Public Utility Commission at (512) 936-7120 or (888) 782-8477. Hearing- and speech-impaired individuals with text telephones (TTY) may contact the Commission at (512) 936-7136. A request for intervention or for further information should refer to Docket No. 42448. Unless otherwise ordered by the presiding officer, motions to intervene will be due 45 days from the date SWEPCO filed its Statement of Intent and Application with the Commission.

OUTPOST DELI  
THIS WEEK'S SPECIAL



Fruit Smoothies  
Blended fruit smoothies

Pomegranate Blueberry • Passion Orange Guava • Banana • Lemon Cooler • Strawberry Sensation

ON SALE \$2<sup>99</sup> regular \$3<sup>99</sup>

## ¿Qué Pasa? Community Calendar

**July 3**  
Depression Lunch • 11 a.m. - 1:30 p.m.

Jr. Ranch Rodeo • 7:30 • COEA arena

**July 4**  
Independence Day

Craft Fair • 9 a.m. • Courthouse Square

Kid's Parade • 10 a.m.

Shriners' BBQ • 11 a.m. • Courthouse Square

Fourth of July Parade • 2 p.m.

Ranch Rodeo • 7:30 • COEA arena

**July 5**  
Turtle Race • 3 p.m. • Downtown Clarendon

Ranch Rodeo • 7:30 • COEA arena

## ★ Menus

June 30 - July 4

**Donley County Senior Citizens**  
Mon: Meatball submarine sandwiches, Italian mix vegetables, tator tots, chocolate cake, iced tea/2% milk.  
Tue: Baked chicken, mashed potatoes, buttered squash, wheat roll, apricots, iced tea/2% milk.  
Wed: Beef pot roast, potatoes, carrots, peppers, green beans, wheat roll, peach cobbler, iced tea/2% milk.  
Thu: Turkey sandwich, tomatoes & lettuce, broccoli & raisin salad, pineapple delight, iced tea/2% milk.  
Fri: Closed

**Hedley Senior Citizens**  
Mon: Polish sausage & Cabbage, pinto beans, coleslaw, cornbread, peaches, iced tea/2% milk.  
Tue: Spaghetti w/meat sauce, Italian vegetables, garlic toast, broccoli, Autumn Jello, iced tea/2% milk.  
Wed: Pork roast & gravy, black eye peas, mashed potatoes, roll, cake, iced tea/2% milk.  
Thu: Chicken tenders, garlic mashed potatoes, turnip greens, wheat roll, mandarin oranges, iced tea/2% milk.  
Fri: Closed

**POSITIVE FEED SALES**  
All-In-One 30% Supplement for Cattle  
Brangus Heifers For Sale  
DANNY ASKEW  
874-5001 or 874-3844

**Country BLUE**  
BED & BREAKFAST  
Now Taking Reservations.  
3 Bedrooms  
Max Occupancy: 7  
Comfortable Living & Dining Room and kitchen.  
Reasonable Rates  
806.874.3937  
or 806.662.2544  
SUE LEEPER  
618 S. PARKS ST.  
CLARENDON

**weather report**

Day	Date	High	Low	Prec.
Mon	16	95°	69°	-
Tues	17	94°	69°	-
Wed	18	91°	61°	-
Thur	19	87°	62°	53
Fri	20	83°	62°	-
Sat	21	85°	67°	-
Sun	22	91°	61°	70

Total precipitation this month: 3.52"  
Total precipitation to date: 6.48"

**weekend forecast**

**Fri., June 27**  
Partly Cloudy / Windy  
91°/69°

**Sat., June 28**  
Isolated T-Storms  
90°/68°

**Sun., June 29**  
Partly Cloudy / Windy  
92°/68°

Information provided by:  
Lori Howard  
National Weather Service

# Beware new tree trimming/spraying scams

Hi, gang! I made it back from Houston, and all is still going okay. That road sure gets longer each month. However MD Anderson is the number one cancer center in the United States.

Let's all be on the lookout for all types of door-to-door salespersons. Summer bring out all of the door-to-door scammers. Beware.

Summer yard maintenance may include hiring someone to spray or trim trees or provide other yard related services. Locally, there are many trustworthy businesses with hard-earned reputations for honesty and quality lawn and tree service. Unfortunately, this is also a type of service that criminals use to take advantage of people especially the senior citizens. Some of the most common frauds originate with door-to-door sales, and we believe that criminals promoting their service in this manner are currently active in Donley County. Before hiring someone for tree or pesticide spraying services, be sure to check them out thoroughly.

Before selling this service door to door, the salesman must obtain a permit as required in the City of Clarendon Municipal Code. They must apply for the permit at the City Hall, and must carry the permit with them. To check out individuals in Hedley, Howardwick, and in Donley County call the Donley County Sheriff's Office. Also, please call the Sheriff's Office when Clarendon City Hall is closed.

The Sheriff's Office will come and investigate them. Individuals that offer commercial spraying service must comply with state licensing regulations and must operate under a permit issued by the Texas Department of Agriculture, which provides this information on their web site: Applicators who want to apply any pesticides (regardless of use classification) to plants, trees, shrubs, grass or other horticultural plants for hire must be licensed by either the Texas Department of Agriculture 3A ag category or the Structural Pest Control Service. Asking those offering this service about their compli-

ance with state licensing requirements may help you identify someone that could apply substandard (or no) product, over charge, or just vanish with your payment. Most often, these people will attempt to prey on senior citizens.

In addition to verifying local and state licensing, check with the Better Business Bureau at <http://www.bbb.org/texas-panhandle/>, or by phone (806) 379-6222. The BBB's information-which is provided to consumers at no cost-can help you decide if a company is one that you want to trust with your money. Don't wait until after you have been scammed to review a company's record.

Even a quick check through any internet search resource can help you gather information about poten-



bob's whittlin'  
by bob watson

tial contractors. You can help prevent crime by providing this information to friends and neighbors and checking on your elderly friends.

Why is My Number Calling Me? A Crazy New Scam.

Scammers are using caller ID spoofing technology to impersonate the phone numbers of local businesses, neighbors and even you! Watch out for this wacky twist on the classic phishing phone scam.

How the Scam Works: Your phone rings, and you look at the caller ID. You recognize the number. It may be from a local business or a neighbor down the street. But in strange twist, you might even see your own name and phone number on the caller ID screen. You answer the phone, and it's a robo call. Victims have reported several different phishing scams. In one common version, a recording prompts you to verify your credit card number under the guise of lowering your interest rates.

With many people rejecting calls from unfamiliar numbers,

scammers are increasingly posing as familiar businesses, government organizations or people. Scammers purchase lists of phone numbers and use spoofing technology to trick potential victims into picking up the phone. Posing as your own phone number is great for shock value and for ensuring the number isn't blocked.

What to do is a scammer calls: Hang up, don't press any buttons and, if you received a voice mail message, don't call the scammer back. We all like to have the last word, but returning the phone call may just give the con artist information he can use. Don't trust Caller ID.

Scammers have technology that lets them display any number or organization name on your screen. Never give out any financial information. If you did not initiate the call, do not provide bank account, credit card or Social Security numbers over the phone unless you have thoroughly done your research and verified the caller.

Be safe out there.

## Rains continue to come our way

If you missed me last week, that was because I took a road trip to Houston along with Ole Jim and our daughter, leaving Buffy the Wonder Dog in the care of other family members.

I know, Houston in June is not an ideal vacation spot but it happens to be where our son lives. The humidity was about the same as it has been here, but the Houston Chamber of Commerce would love to have our cool mornings. The traffic and urban sprawl would drive me nuts, Ole Jim said he would become a stay-at-home-Grandpa if he lived down there. We thoroughly enjoyed the San Jacinto Monument and Battleship Texas, two icons of Texas history.

The Battle of San Jacinto was the last battle of the Texas Revolution led by Sam Houston for Texas and Santa Anna for Mexico. After defeats at many places including the Alamo and Goliad, the Texas Army numbered about 1,000. Houston and the army were being chased by Santa Anna and his army of about 2,000 with reinforcements coming fast.

The area Houston selected as defensive was reached by marching through a bayou with groves of trees and the San Jacinto River at the rear. The Lynchburg Ferry crossed near the battlefield.

As Santa Anna led his troops toward Houston, he stopped and decided to rest and whip those Texans the next day. Even though the two camps were near, Santa Anna neglected to post sentries which allowed the Texans to come within 300 yards before being detected. With cries of "Remember the Alamo" and "Remember Goliad" the battle lasted less than an hour and resulted in the Mexican Army defeat with 630 killed, 208 wounded, and 730 captured, including Santa Anna who attempted to escape dressed as a slave. With Santa Anna as a prisoner of war, he was used to bargain which



'wick picks  
by peggy cockerham  
Howardwick • 874-2886

included all hostilities would cease, sending the surviving army home, and establishing the Rio Grande River as the boundary between the two countries.

Written on the base of the Monument reads, "Measured by its results, San Jacinto was one of the decisive battles of the world." Good job, Texans! I'm proud to say I am a Texan.

The rains have continued. We received another inch Sunday night. I am happy to say most of the state we saw had received rain. Of course, with rain comes weeds and mosquitoes. I have heard a new dryer sheet will keep them away so I am doing my own experiment with them. My California granddaughter said to put one in your pocket and they wouldn't come near you. We will see. I'd rather do that than spray with a chemical.

Our maintenance man, Doc Holliday, has reported seeing skunks out during the day which could mean possible rabies, so keep on the alert and keep your pets vaccinated against rabies.

## Donley County 4-H to host free horsemanship clinic

The Donley County 4-H is hosting this free horsemanship clinic on Thursday, July 10, at the Clarendon College Livestock & Equine Center.

The Hi-Pro Feeds Horsemanship Clinic will be held from 9 a.m. to 4 p.m. and is for any area kids that are interested in attending. This clinic has been developed to educate all facets of successful showing of the Stock Horse and teaching the student how to prepare for sanctioned horse show events.



The Clarendon Lions Club held its regular Tuesday noon meeting June 24, 2014, with Boss Lion Ashlee Estlack in charge.

We had 15 members and three guests this week, Abby Johnson, guest of the club; and Nathan and Daniel Estlack, guests of Lion Russell Estlack.

Lion Robert Riza updated the club on college activities and mentioned that the FFA Leadership Camp is being held on campus this week. He also reported success with a new initiative that is preparing high school students for college coursework.

Lion John Taylor said maintenance and re-takes of state tests are keeping folks busy at the public school.

The Boss Lion reported that the Chance Mark Jones Memorial Playground is nearing completion and said a dedication and ribbon cutting will be held Thursday, July 3, at 11:30 a.m.

Miss Johnson introduced herself and fielded questions from club members. Afterwards, she was elected to serve as our next Sweetheart and will begin her official duties when new officers are sworn in on July 15.

There being no further business, we were adjourned.

This will include everything from basic and intermediate horsemanship to the proper use of equipment, behavior modification, nutrition, safety, management, grooming, etc. It is the intention of the clinic program staff to encourage equine interest and knowledge through hands on demonstrations as well as classroom instruction. The student will complete horseback exercises and must provide their own horse. A "Release of Liability Form"

will be provided and must be signed for student to participate.

The clinic will have a morning and afternoon session with lunch provided by Hi-Pro Feeds. The afternoon session will conclude with a small horse show situation where students will be evaluated and placed according to performance followed by an awards presentation. Those wishing to attend must RSVP by July 8 to the Extension Office at (806)874-2141.

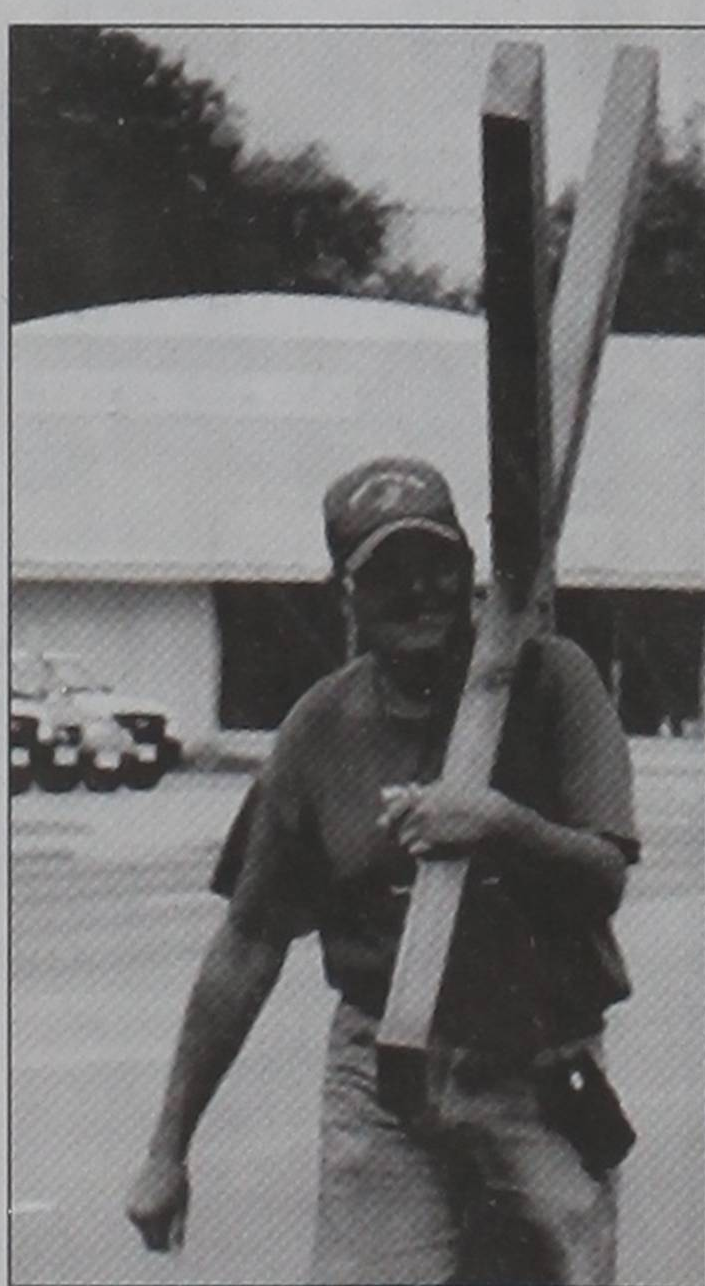

Last Thursday Walter Masters carried his cross through Clarendon. Originally from San Angelo Master travels the US bring the word of God to those he meets on his travels.

ENTERPRISE PHOTO / TARA HOGAN

## Quilting Club meets

Golden Needles Quilting Club met in the Cole home for quilting for the day with these ladies present - Gay Cole, Ann Bunyan, Mary Lynn Manning, Barbara Helms, Jo Shaller, Wilma Lindley, Dixie Ward, Dortha Reynolds, Mary Lynn, Wilma Callis, Frances Smith, Josie Burgess, Barbra Pichter. Didn't quite finish the quilt.

Subscribe Today

**Kenny's Barber Shop and Clarendon Auto Sales**  
3rd & Jefferson, Clarendon  
874-9308  
We appreciate your business!

**PHELPS PLUMBING**  
heating • air-conditioning  
806-874-1675  
HVAC# TACLB3255E PLUMBING # 12746



Clarendon College officials had a brush with fame during the annual meeting of the Community College Association of Texas Trustees in San Antonio earlier this month. CC President Robert Riza (right) along with CC Regents Ruth Robinson, Tex Selvidge, Jerry Woodard, and Delbert Robertson were fortunate to run into and have their picture made with a Pro Football Hall of Fame member, former NFL running back and MVP Eric Dickerson.

CC PHOTO / ASHLEE ESTLACK

Subscribe Today. Call 874-2259.

**Germania INSURANCE**  
Joey & Brenda Lee  
Lee's Insurance  
PO Box 189 • Clarendon, Texas 79226  
806.874.2130  
HOME • AUTO • LIFE • COMMERCIAL

**Morrow Drilling & Service**  
Hwy. 287 West, Clarendon  
Water Well Specialist • Turnkey Systems  
Solar Windmill • Electric Irrigation  
30 Years Experience  
John E. Morrow (806)874-2704 • (806)662-3943

**Drugs in the News**  
**Antipsychotics May Reduce Violent Crimes**  
A recent study conducted in Sweden reports that prescribing antipsychotics to people with psychiatric disorders may reduce the incidence of violent crimes in that group of people. Through a search of the records, researchers compared the rate of violent crime when individuals were or were not taking an antipsychotic medication. Compared with the period these individuals were not on their medication, violent crime decreased by 45 percent when these same individuals were taking their antipsychotic medication. Antipsychotics are commonly prescribed worldwide to manage psychotic conditions such as delusions, hallucinations, disordered thought and in the management of schizophrenia and bipolar disorder. Antipsychotics are known to be effective for prevention of relapse into psychosis and symptom relief. However, prior to the study in Sweden, the effects on violent crime were unknown. Antipsychotic medications fall into two categories, typical such as haloperidol and atypical such as risperidone. Both types block dopamine pathways in the brain. Atypical antipsychotics also act on serotonin receptors.  
**Rx Mike's PHARMACY**  
Call 874-3554 or Toll Free 800-766-2089  
Hwy 287 West • Clarendon, Texas

137<sup>TH</sup> ANNUAL  
**SAIN'TS' ROOST**  
**CELEBRATION**  
**JULY 3, 4 & 5**



**JR. RANCH RODEO**

July 3, 2014 • 7:30 p.m.

FREE ADMISSION 16 & UNDER WITH ADULT TICKET.

Calf Scramble - ages 12 and under.

Open Jr. Donkey, Calf & Steer Riding, Mutton Bustin'

Ages 0-8 & 9-12, \$20 entry fee. Sponsored by Donley County State Bank.

\*\*\*\*\*

**Ranch Rodeo**

ROUGH STOCK BY BILL HEXT • ANNOUNCER: ED MONTANA

July 4 & 5, 2014 • 7:30 p.m.

BOX SEAT SALES \$150 for ALL THREE NIGHTS. Call Ken @ 806/672-3576

**FREE \$200 BEEF**

CERTIFICATE DRAWING EACH NIGHT.

\*\*\*\*\*

**OPEN AIR DANCE** 9 P.M. TO 1 A.M.

JULY 3 DJ - ALL ABOUT MUSIC

JULY 4 NO DRY COUNTY

JULY 5 MATT MARTINDALE BAND

\*\*\*\*\*

**SCHEDULED  
EVENTS:**

- Thursday, July 3** All Day - Clarendon Merchant Sales  
 11:00 a.m. - Depression Lunch, Downtown  
 11:30 a.m. - Chance Jones Playground  
 Dedication at City Park  
 7:30 p.m. - Jr. Ranch Rodeo, COEA Arena  
 9:00 p.m. - Dance, COEA Slab
- Friday, July 4** 9:00 a.m. - Craft Fair,  
 Courthouse Square  
 10:00 a.m. - Old Settlers Reunion,  
 Courthouse Square  
 10:00 a.m. - Kids' Tricycle/Bike Parade  
 11:00 a.m. - Shriners' Barbecue,  
 Courthouse Square  
 2:00 p.m. - Western Parade  
 AFTER PARADE - Lions Cow Patty Bingo  
 7:30 p.m. - Ranch Rodeo, COEA Arena  
 9:00 p.m. - Dance, COEA Slab
- Saturday, July 5** All Day - Clarendon Merchants' Sales  
 3:00 p.m. - Henson's Turtle Race,  
 Downtown  
 7:30 p.m. - Ranch Rodeo, COEA Arena  
 9:00 p.m. - Dance, COEA Slab

**Clarendon**  
 T E X A S

SPONSORED BY THE CLARENDON OUTDOOR ENTERTAINMENT ASSOCIATION.

### Scenes from Hart-Moore Field

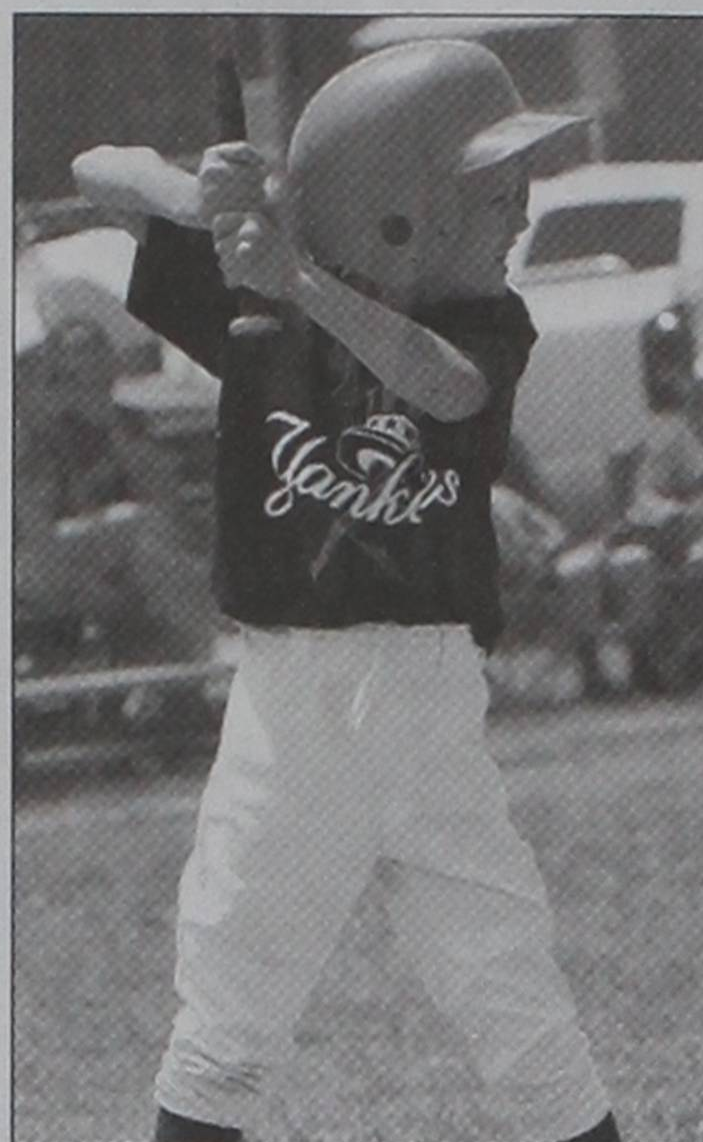

### Sheriff's Report

#### June 16, 2014

12:19 a.m. - Checking open door at Clarendon College  
 1:36 a.m. - To jail with one in custody  
 2:19 a.m. - Check 800 block South Kearney  
 2:41 a.m. - Check area 400 block East Wood  
 3:28 a.m. - Check area 300 block Collinson  
 4:05 a.m. - Check area 500 block East 4th  
 4:22 a.m. - Open door CISD  
 4:49 a.m. - EMS assist 300 block South Jefferson  
 8:43 a.m. - Units paged vehicle accident HWY 273  
 1:09 p.m. - Units paged vehicle fire 200 block East 4th  
 10:19 p.m. - EMS assist 300 block South McLean

#### June 17, 2014

3:27 p.m. - EMS assist Clarendon Family Medical Center  
 7:28 p.m. - EMS assist 300 block North Bailey  
 8:07 p.m. - Units paged motorcycle accident HWY 70 North

#### June 18, 2014

2:47 p.m. - Units paged to grassfire 120 North  
 7:34 p.m. - Welfare check 1400 block Railroad  
 9:33 p.m. - EMS assist 500 block South Hartzell

#### June 19, 2014

12:28 a.m. - Semi stuck in ditch 287 & Co Rd 26 A  
 1:07 a.m. - Commercial burglar alarm 600 block West 2nd  
 1:35 a.m. - Courtesy ride to residence on South Parks

8:11 a.m. - Vehicle parked in roadway 6<sup>th</sup> & Collinson  
 9:34 a.m. - Units paged grassfire 203 & Co Rd V  
 2:24 p.m. - Out @ Annex  
 6:01 p.m. - EMS assist 100 block North Sully  
 6:18 p.m. - EMS assist 100 block Blair

#### June 20, 2014

12:17 a.m. - EMS assist mutual aid Hall Co  
 4:40 a.m. - Check rest area for overdue motorist  
 7:50 a.m. - Loose livestock West of Lelia Lake  
 11:59 a.m. - Units paged vehicle accident 287 & 70 South  
 3:46 p.m. - EMS assist 400 block North Bailey  
 4:44 p.m. - EMS assist 700 block Collinson  
 7:52 p.m. - EMS assist at Goodnight

Clarendon **LIVE**.com

The Clarendon Church of Christ invites you to watch **"In Search of the Lord's Way"** every Sunday morning at 7:30 on KAMR Channel 4.

**ACE PEST CONTROL**  
 "Is your place an ace place?"  
 Terry & Jason Wheeler, C.A. TPCL 10615  
 www.acepestcontrol.pro  
**806-372-5449**  
 ace.pest@yahoo.com  
 We Specialize in General Pest, Termite, Pretreatments  
**TERMITE SEASON FAST APPROACHING. CALL US FOR INSPECTIONS.**

Nita Massey, LNFA Administrator  
**Memphis Convalescent Center**  
 (806) 259-3566 Phone  
 (806) 259-5098 Fax  
 (806) 205-2442 Cell  
 Nita\_Massey@csnhc.com  
 1415 N. 18th Street  
 Memphis, Texas 79245  
 www.memphisconvalescent.com

**2014 Fourth of July Parade Entry Form**

Name \_\_\_\_\_  
 Company Name \_\_\_\_\_  
 Address \_\_\_\_\_  
 Home Phone \_\_\_\_\_  
 Category: Float  Antique Vehicle  Band   
 Farm Equip.  Riding Units  Van  Other   
 Description for MC: \_\_\_\_\_

Sign-in and line-up will be at 1:00 p.m. on July 4<sup>th</sup> Parade at 2 p.m.  
 Line-up will be on 6<sup>th</sup> St. just North of the City Park by the baseball field.  
 For more information contact the Chamber of Commerce at 874-2421 or call Bonnie Campbell at 205-3150  
 Deadline for entry form is July 2<sup>nd</sup>  
**Cash prizes will be awarded!**  
 Please mail entry form to Chamber of Commerce, P.O. Box 986, Clarendon, TX 79226, or leave it at the Chamber Office located at 110 Kearney St. You can also drop it in the box beside the door.  
 Or, Fax to: 806-874-2911  
 email to: contact@ClarendonChamber.com

**4<sup>th</sup> of July Kids Parade**  
**2014 - Bicycle & Tricycle Parade Entry Form**  
 Deadline for entry form is Wednesday, July 2

Name \_\_\_\_\_  
 Age \_\_\_\_\_  
 Address \_\_\_\_\_  
 Home Phone \_\_\_\_\_  
 Division: Bicycle  Tricycle

• The Kid's Parade will be on July 4th at 10 a.m.  
 • Registration & lineup at 9:30 a.m. in front of Henson's.

For more information call the Chamber of Commerce at 874-2421 or Bonnie Campbell at 205-3150 or e-mail the Chamber at: contact@ClarendonChamber.com  
 Please fill out the entry form and mail it to P.O. Box 986, Clarendon, TX 79226, or leave it at the Chamber of Commerce Office located at 110 Kearney St.  
 If we are out, you can leave it in the box beside the door.

**4-M DRILLING**  
 IRRIGATION, DOMESTIC, TEST HOLE  
**GOULDS AND SIMMONS PUMPS**  
 JOE MORROW, OWNER  
 P.O. Box 701 CLAUDE, TX 79019 806.226.5023 806.681.7150

**WFW**  
**SPECIAL**  
 Loaded Stack with toast and drink.  
**\$7.00 donation**  
**OPEN**  
 Monday - Friday  
 6 a.m. - 10 a.m.  
 Sat. 6:30 a.m. - 10:30 a.m.

**FIGHT CAVITIES**

How can you beat tooth decay?  
 Brush, floss and see your dentist regularly for cleanings and checkups! We offer gentle care for growing smiles.

Family Dentistry • Orthodontics • Implants • Bleaching

**Richard Sheppard, DDS**  
 Located in the Community Services Building, Medical Center Campus in Clarendon  
**Now listed in the White Pages!**  
**806-874-5628**

**Worship DIRECTORY**

- CLARENDON**  
**AGAPE CHRISTIAN CHURCH**  
 712 E. 2ND (HWY. 287) • MINISTER: ANTHONY KNOWLES  
 SUN. SCHOOL: 9:30 A.M. • SUN. SERVICE: 10:30 A.M.
- CALVARY BAPTIST CHURCH**  
 US 287 E • 874-3156 • REV. ROB SEALE  
 SUN. SCHOOL: 10 A.M. • SUN. SERVICE: 11 A.M.  
 SUN. EVENING: 7 P.M. • WED.: 7 P.M.
- CHURCH OF CHRIST**  
 300 S. CARHART • 874-2495 • MINISTER: CHRIS MOORE  
 SUN. BIBLE CLASS 9:30 A.M. • SUN. SERVICE: 10:30 A.M.  
 SUN. EVENING: 7 P.M. • WED.: 7 P.M.
- CHURCH OF NAZARENE**  
 209 S. HAWLEY • 874-2321 • PASTOR: BILL HODGES  
 SUN. SCHOOL: 9:30 A.M. • SUN. SERVICE: 10:30 A.M.  
 SUN. EVENING: 6 P.M. • WED.: 7 P.M.
- COMMUNITY FELLOWSHIP CHURCH**  
 12148 FM 2162 • 874-0963  
 PASTOR: LARRY CAPRANICA  
 SUN. SCHOOL: 10 A.M. • SUN. SERVICE: 11 A.M.  
 SUN. EVENING: 6 P.M. • WED. COMMUNITY KIDZ 5:30 P.M.  
 WED. ADULT BIBLE STUDY: 6 P.M.
- FIRST CHRISTIAN CHURCH**  
 120 E. THIRD ST. • PASTOR: DARRELL BURTON  
 SUNDAY SERVICE: 5 P.M.
- FIRST ASSEMBLY OF GOD**  
 4TH ST. & HWY. 70 SOUTH • PASTOR: MATTHEW STIDHAM  
 SUN. SCHOOL: 9:45 A.M. • SUN. SERVICE: 10:40 A.M.  
 SUN. EVENING: 6 P.M. • WED. YOUTH: 6:15 P.M.  
 WED. BIBLE STUDY: 7 P.M.
- FIRST BAPTIST CHURCH**  
 300 BUGBEE AVE. • 874-3833 • REV. LANCE WOOD  
 SUN. SCHOOL: 9:45 A.M. • SUN. SERVICE: 10:55 A.M.  
 SUN. EVENING: 6 P.M. • KID'S ACTIVITIES: WED. 6 P.M.  
 YOUTH STUDY: WED. 7 P.M.  
 COLLEGE MINISTRY: WED. 9 P.M.
- FIRST PRESBYTERIAN CHURCH**  
 FOURTH & PARKS • PASTOR: REV. ROBIN GANTZ  
 FELLOWSHIP: 10:30 A.M.  
 SUN. SERVICE: 11 A.M.
- FIRST UNITED METHODIST CHURCH**  
 420 S. JEFFERSON • 874-3667 • PASTOR LLOYD STICE  
 SUN. SERVICE: 9:45 A.M. • SUN. SCHOOL: 11 A.M.
- JESUS NAME APOSTOLIC CHURCH**  
 720 E. MONTGOMERY • 205-1149 • REV. 874-2078  
 REV. CALVIN BURROW  
 SUN. SERVICES: 3 P.M. • WED.: 7 P.M.
- BODY OF CHRIST MINISTRIES:**  
 501 S. MCCLELLAND • PASTOR: R.W. ELLERBROOK  
 SATURDAY: 6 P.M. • SUNDAY DISCIPLESHIP CLASS: 9:30 A.M.  
 SUN.: 10:30 A.M. • SUN. LIFE GROUP: 4:30 P.M.  
 WED.: 6:30 P.M.
- CHRIST'S KIDS OUTREACH MINISTRY:**  
 416 S. KEARNEY • JANET STEVE CARTER • 874-2007  
 SUN. BREAKFAST: 9:30 A.M. • SUN. PRAISE & WORSHIP: 10 A.M.  
 SUNDAY SCHOOL: 10:30 A.M. • WED.: 5 P.M.
- ST. JOHN THE BAPTIST EPISCOPAL CHURCH**  
 301 S. PARKS ST. • 874-2511 • REV. JIM AVENI  
 FIRST SUNDAY SERVICE: 11 A.M.
- ST. MARY'S CATHOLIC CHURCH**  
 MONTGOMERY & MCCLELLAND  
 FR. ARONIA RAI SAKALA  
 SUN. MASS 11 A.M.
- ST. STEPHENS BAPTIST CHURCH**  
 300 N. JEFFERSON ST. • PASTOR: ROY WILLIAMS  
 SUN. SCHOOL: 10 A.M. • SUN. SERVICE: 11:15 A.M.  
 WED.: 7 P.M. (WEATHER PERMITTING)
- TRUE CHURCH OF GOD & CHRIST**  
 301 N. JEFFERSON • ST. PASTOR: JEFF RILES  
 SUN. SCHOOL: 10 A.M. • SUN. SERVICE: 11:15 A.M.  
 WED.: 7 P.M.

**HEDLEY**  
**CHURCH OF CHRIST**  
 110 E. SECOND ST. • MINISTER: BRIGHT NEWHOUSE  
 SUN. BIBLE CLASS: 10 A.M. • SUN. SERVICE: 11 A.M.  
 SUN. EVENING: 6 P.M. • WED.: 7:30 P.M.

**FIRST UNITED METHODIST CHURCH**  
 200 N. MAIN ST. • PASTOR: STAN COSBY  
 SUN. SERVICE: 4:00 P.M.

**FIRST BAPTIST CHURCH**  
 210 N. MAIN ST. • 856-5980 • PASTOR: BRUCE HOWARD  
 SUN. SCHOOL: 10 A.M. • SUN.: 11 A.M. & 6 P.M.  
 WED.: 7 P.M.

**HOWARDWICK**  
**FIRST BAPTIST CHURCH**  
 235 RICK HUSBAND BLVD. • 874-3326 • REV. DAVE STOUT  
 SUN. SCHOOL: 10 A.M. • SUN. SERVICE: 10:45 A.M.  
 SUN. EVENING: 6 P.M. • WED.: 6 P.M.

**OLD PATHS PRIMITIVE BAPTIST CHURCH**  
 HERFORD LANE AT HWY 70 • 873-1770  
 3RD SUNDAYS - DON MARTIN • 4TH SUNDAYS - DON WATSON  
 SERVICES: 10:30 A.M.

**MARTIN**  
**MARTIN BAPTIST CHURCH**  
 US 287 W  
 SUN. SCHOOL: 10 A.M. • SUN. SERVICE: 11 A.M.  
 SUN. EVENING: 6 P.M. • WED.: 7 P.M.

**BRICE**  
**BRICE DELIVERANCE TABERNACLE**  
 PASTOR: LOUIS BENNETT  
 SUNDAY: 9:45 A.M. • SUN. EVENING: 6 P.M.  
 WED.: 6 P.M.

**SPONSORED BY**  
**ROBERTSON FUNERAL DIRECTORS**  
**COUNTRY BLOOMERS FLOWERS & GIFTS**  
**WALLACE MONUMENT CO.**

**MCKINNEY MOTOR CO.**  
**3-H ALL NATURAL BEEF**  
**CLARENDON FAMILY MEDICAL CENTER**  
**ROLLING PLAINS AG COMPOST**  
**J&W LUMBER**  
**PILGRIM BANK**

For corrections or additions, call the Enterprise at:  
**874-2259**

# Big E Classifieds

Call in your ad at  
**874-2259**

Deadline: Monday @ 5 p.m.  
Prepayment required.  
Visa / MasterCard accepted.

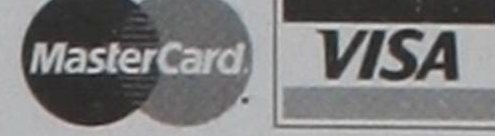

### MEETINGS

**Clarendon Lodge #700 AF&AM** Stated meeting: Second Mondays, 7:30 p.m. Refreshments at 6:30 p.m. Practice: Fourth Mondays, 7 p.m. Jim Owens - W.M., Grett Betts - Secretary, 2 B I, ASK 1

**Donley County Memorial Post 7782** Veterans of Foreign Wars. Meets first Tuesday at 7 p.m. 822-VETS.

**Clarendon Lions Club** Regular meeting each Tuesday at noon. Ashlee Estlack, Boss Lion. Roger Estlack, Secretary

**Clarendon Chamber of Commerce** Regular meeting 2nd Thursday each month at 5:30 p.m. at Burton Memorial Library.

**Big E Meeting Listings** only \$8.50 per month. Call 874-2259 to have your club or organization meeting listed.

### HELP WANTED

**SUMMER JOB** Best Western Red River Inn is taking applications for a Housekeeping Attendant. Please apply in person.

**PART TIME HELP WANTED** in my home, childcare, cooking and cleaning. References needed. Hours varied. Call for more information 806-338-1884

**CORNELL'S COUNTRY STORE** is hiring. Must be able to load feed and hay. Forklift experience a plus. Must have dependable transportation, a valid driver's license and be able to work Monday thru Saturday. Apply in person at 903 E Hwy 287, Clarendon.

**THE CITY OF CLARENDON** is accepting applications for a part time office assistant. Must have HS Diploma/GED, and excellent customer service skills. Pre-employment drug/alcohol screen required. Applications available at City Hall 119 S. Sully.

**THE CLARENDON CHAMBER OF COMMERCE** is taking applications for the position of Chamber Manager. Proposed schedule is 30 hours per week and primary duties include book-keeping, record keeping, maintaining communications, leading member services, coordinating Chamber events and activities, and developing strategies to promote local commerce. For a complete job description and an application, contact Bonnie Campbell at the Clarendon Visitor Center at the Mulkey Theatre or by calling 806-874-2421.

**THE CLARENDON ECONOMIC** Development Corporation is seeking applications for the Director of Tourism & Economic Development. The primary function of this position is to encourage appropriate tourism and business development for the City of Clarendon, direct and manage the Clarendon EDC and Clarendon Visitor Center, and provide supervision and counsel to the Clarendon Chamber of Commerce. Estimated job start time is September 1, 2014. For a complete job description, contact Chandra Eggemeyer at tourism@cityofclarendontx.com

**THE CLARENDON HOUSING AUTHORITY** is accepting applications for maintenance help. Applications will be taken until July 2nd. Applications will be screened at that time. Applicant must be able to assist with a wide variety of maintenance and repair work on facilities and equipment. Must be able to work with public. Must possess valid driver's license. Applicant must be able to pass background check and provide references. For more information please call Tammy at 806-874-2458 or come by the Housing Authority office at 103 E. 4th between 8:00 a.m. and 3:00 p.m. to fill out an application.

### REAL ESTATE

**Jim Garland Real Estate**  
806-874-3757  
• Have buyers for ranches, farms, & recreational properties.

**Shannon's Rt. 66 Realty**  
207 E 12th St., Shamrock, TX 79079  
806-259-1616 • 806-676-0373

3263 County Road P (Hermesmyer Farm) 30.5 Acres of grass located off of US HWY 287 NW of Clarendon, TX, across from Panhandle Road & Field Services. Fence is in excellent condition and grass has not been grazed in several years. Property has a 3 bed room, 2 bath, home, a domestic well, and several storage buildings.

### FOR RENT

**FOR RENT:** 2 bedroom. Call 874-0043 for more information.

### REAL ESTATE

**CUTE 2BR/2BATH HOME** in Clarendon. \$46,000. Central heat/air, fenced yard, updated interior. Call 469-619-7155 for information.

**VICTORIAN STYLE TWO** story house in Hedley for sale. Four bedroom 2 bath. Lots of trees on 1.5 acres. 125 SE 6th St. \$21,500. 806-662-1095

**14X80 (1983) MANATEE** mobile home on 6 lots. Saints Roost Edition, 3 bedroom, 1 1/2 bath, ch/fenced backyard, storm shelter, pole barn, shop, storage building \$25,000.00. 806-202-0965 or 806-202-0967

**NICE HOME FOR SALE** in Howardwick. 2000 square feet, 3 bedroom, 2 bath, large den with fireplace, central heat & air, formal dining room, breakfast nook, new paint, new carpet, new tile, 17x22 den with 14 ft ceilings, and 30x30 garage under house. Located on 4 lots, with back garden house with single garage. Call 874-9392 or 336-9131 for more information.

### THANK YOU

WE WOULD LIKE to thank the people of Clarendon for their prayers, visits, cards, and calls of concern and support following Audrey's accident. We are blessed to live in such a caring community.  
Audrey Shelton Family

### SERVICES

**ASKEW'S LAWN MOWING SERVICE** call Dale at 806-679-2738.

**SMALL ACREAGE PLANTING**, fertilizer & compost spreading, disking, and rototilling. Call Jobots at 806-205-0270 for a free estimate. 11-ctfc

### ANNOUNCEMENTS

**Saints' Roost Museum**  
610 East Harrington  
**Tuesday - Saturday**  
10 a.m. to 5 p.m.  
Open for appointments.  
Call 874-2746.

**FACILITIES AVAILABLE** - Family Reunions, Receptions, Business Meetings, Club Functions, and more. Clarendon Lions Hall, 111 W. Fourth. Call Melinda at 874-3521 for rental information.

### HELP WANTED

**Palo Duro Nursing Home**  
Claude, Texas

Has the following positions available:

- Full-time Cook
- Dishwasher
- Housekeeping

Call 806-226-5121

### HELP WANTED

**THE CLARENDON CHAMBER OF COMMERCE** is taking applications for the position of Chamber Manager. Proposed schedule is 30 hours per week and primary duties include book-keeping, record keeping, maintaining communications, leading member services, coordinating Chamber events and activities, and developing strategies to promote local commerce. For a complete job description and an application, contact Bonnie Campbell at the Clarendon Visitor Center at the Mulkey Theatre or by calling 806-874-2421.

**THE CLARENDON ECONOMIC** Development Corporation is seeking applications for the Director of Tourism & Economic Development. The primary function of this position is to encourage appropriate tourism and business development for the City of Clarendon, direct and manage the Clarendon EDC and Clarendon Visitor Center, and provide supervision and counsel to the Clarendon Chamber of Commerce. Estimated job start time is September 1, 2014. For a complete job description, contact Chandra Eggemeyer at tourism@cityofclarendontx.com

**THE CLARENDON HOUSING AUTHORITY** is accepting applications for maintenance help. Applications will be taken until July 2nd. Applications will be screened at that time. Applicant must be able to assist with a wide variety of maintenance and repair work on facilities and equipment. Must be able to work with public. Must possess valid driver's license. Applicant must be able to pass background check and provide references. For more information please call Tammy at 806-874-2458 or come by the Housing Authority office at 103 E. 4th between 8:00 a.m. and 3:00 p.m. to fill out an application.

**LINDA M. NAYLOR REAL ESTATE**  
Providing a Personal Touch!  
Texas Licensed Real Estate Broker  
License # 604414  
Cell Phone: (806) 204-0005  
403 N. Johnson St., Hedley, Texas 79237

e-mail: maylorl@windstream.net

**Home for Sale in Hedley:** Brick home at 420 Railroad St. Sits on 4 Lots. 1900 Sq. Ft., 3/4 Bedrooms, 2 Baths, Two-car garage, Covered patio, Carport, Huge storage building, Fenced backyard, corner Lot. Price: \$74,500.00

**For sale in Hedley:** Brick home at 411 Johnson St. 1538 Sq. Ft., 3 Bedrooms, two bathrooms, two-car garage, huge covered patio, fenced backyard. Corner Lot. Price: \$80,000.00

**Amazing Home and 1 acre of land:** 2158 sq. ft., 4 bedrooms, 2 & 1/2 Baths, finished basement, city water, city sewer, water well, mature landscaping. 605 S. Orpe on 70 S. \$160,000.00

**702 E. Wood St:** 1716 Sq.Ft., Corner Lot, 3 Bedrooms, 2 Baths, Basement, Carport. Bargain Price: \$65,000.00

**Charming Remodeled Two-story Home Corner lot** at 521 4th Street. 2072 Sq.Ft., 3 Bedrooms, 2 Baths. Reasonably Priced at \$68,000.00.

**4000 sq. ft. building** with a commercial overhead door in the back storage area Located on HWY 287 in the business district. \$74,999.00

**Lot at 113 Walleye** Howardwick, Texas. Price \$600.00

**320 ACRES WITH HOME** AND TWO WELLS HIGHWAY 70 SOUTH. Excellent perimeter and cross fences \$1550 PER ACRE. OWNER WILL SPLIT ACREAGE INTO SMALLER TRACTS UPON REQUEST.

**3 BEDROOM / 2 BATH** 2200 S. WILSON ST. HOME RECENTLY RENOVATED WITH BASEMENT PRICED TO SELL AT \$12,000.00. **UNDER CONTRACT**

**Two Bedroom, 1 bath** trailer on two lots appliances included in sale. Nice carport and cellar. 357 Walleye St., Howardwick, Texas. \$19,500.00.

**COMING SOON:** Newly built duplexes. Call for details

**For Lease or Sale**  
Beautifully restored and totally renovated commercial office building. Brick with 1500 sq. ft. and a 750 sq. ft. basement New wiring, plumbing, wood floors, windows and central heat/air. Two bathrooms and one is a handicap accessible bathroom Several offices and a conference room. Handicap ramp READY TO MOVE IN AND SET UP YOUR BUSINESS. Owner will entertain reasonable offers. REDUCTION OF \$10,000.00 FROM \$175,000.00 TO \$165,000.00.

**260 Sunfish Circle** A fisherman's delight. 3/4 bedroom, 1 full bath, 1 3/4 bath, RV Port, garage, established pool, covered patio. Price \$59,500.00. **UNDER CONTRACT**

**Brick house at 1112 West 8th** in Clarendon. 2 bedroom, 1 bath. Detached garage with studio apartment, carport, fenced backyard. Needs some TLC. Price reduction \$40,000.

**710 S. Goodnight:** 3 Bedroom/2 Bath w/ garage apartment \$59,900.00

**Pictures at [lmmaylorrealestate.com](http://lmmaylorrealestate.com)**

### FOR SALE

**702 S. Gorst • Clarendon**  
**Blue house, one acre,**  
**3 bedroom, 1 1/2 bath.**  
Super neat place!  
Call Cindy at 806-677-4461.

### GARAGE SALE

**HUGE SHOP-GARAGE SALE**  
June 27 & June 28  
410 Libern Drive, Howardwick  
Across Carol Creek-Follow Signs.  
Friday from 5:00 p.m. to 7:00 p.m.  
Saturday from 7:00 a.m. to 2:00 p.m.  
Tools of all kinds and ages. Stock trailer, Show box with supplies, Wood craft items, (Mid-size garden tractor with bush hog and loader), Cement mixer. Scroll saw, Table saws. Picture frame molding and chopper, Glass insulators, Copper tubing and rolls of electrical wire, Old shovels, Axes, Almost new fiber glass, 500 gal. water tank, Generator (like new), Tool boxes, Heavy duty shelves, Sockets, Propane bottles, Antique items of all kinds, Old pop bottles and crates, Franklin Wood burning stove, Wood chipper, Tool boxes, Craftsman tool chest, and much, much more.

### REAL ESTATE

**Joe T. Lovell Real Estate**  
202 W. 3rd St.  
Call 806-874-9318 to schedule a showing of the following listings.

Visit [www.joetlovellrealestate.com](http://www.joetlovellrealestate.com) to view pictures and details.

### CLARENDON

**3 BEDROOM - 2 FULL BATHS - PLUS EFFICIENCY APARTMENT** - 1850 sq ft main house - eat in kitchen with built in appliances & plentiful counter top & cabinet space - abundant built in storage & closets in all rooms plus hall - central heat/air - 24'X13' apartment with 3/4 bath - unattached 2 car garage - 2 car port - covered patio - fenced back yard - landscaped - large concrete cellar under garage with inside entrance - close to school & shopping area @ 609 W. 3rd for \$69,000.

**EXCEPTIONAL 2 BEDROOM - ONE BATH - BRICK IN WEST CLARENDON** - oversized attached garage includes shop with counter top and storage cabinets - like new kitchen cabinets & counter top - refrigerator - d/washer - work island/ breakfast table combo - pantry - living room includes mock fireplace with electric burner - bath with tub/shower - large concrete cellar with shop/storage bldg. on top - 2 car port plus high rise RV port - beautiful patio with many extras - a must see @ 1305 W. 6th for only \$57,500. **UNDER CONTRACT**

**HOUSE AND 2 1/2 ACRES, M/L. OF BEST COMMERCIAL DEVELOPMENT PROPERTY IN CLARENDON** - some modern upgrades - potential for more - PROPERTY HAS FRONTAGE ON US HWY 287 ON NORTH, SIMS ST ON WEST AND 3RD ST ON SOUTH - an excellent investment for \$135,000.

### GREENBELT LAKE

**3 BEDROOM - 4 BATH - WITH NEW ROOF** - large tress & lots of shrubbery - deer, turkey and wild birds enjoy this place and so will you - West side of lake on Lease Lots #27 - for \$145,000. REDUCED TO 137,500.

### CLAUDE RESIDENTIAL

**2323 SQ FT BRICK** - open den/kitchen - built in appliances - beautiful wood cabinets - built in desk - Murphy bed in den - very large living/ dining room - 2 & 1/2 baths (one private with master bedroom) - large utility room - abundant storage - attached 2-car garage - central h/a - chain link fenced b/yard - efficiency apartment built over large concrete cellar - good location at 307 Western for \$135,000.

### CLAUDE COMMERCIAL

**CHOICE BUSINESS BUILDING SITE** - Intersection of Hwy 287 and State Hwy 207 North with frontage on both busy highways. Diagonally across Hwy 287 from new Cefco complex - survey available.

### RANCH AND FARMLAND

**EXCEPTIONAL 2272 ACRE OPERATING AND HUNTING RANCH IN THE MIDDLE OF THE BEST DEER, TURKEY AND QUAIL HUNTING IN THE PANHANDLE** - recently remodeled ranch home - abundant well water plus lake and large pond - good corrals - modern/rustic hunting lodge plus hunter's bunk house with cooking and sleeping facilities - the ideal working and recreational ranch - (DIVIDING INTO THREE TRACTS OF 1280 ACRES - 588 ACRES AND 403 ACRES +/- A POSSIBILITY) check out the pictures on [www.joetlovellrealestate.com](http://www.joetlovellrealestate.com) > Farms & Ranches > Collingsworth County - then call for details.

## STATE & REGIONAL

### TEXAS STATEWIDE CLASSIFIED ADVERTISING NETWORK

# TexSCAN

**TexSCAN Week of June 22, 2014**

#### BUSINESS OPPORTUNITY

**BE THE 1st Medical alert company in your area!** Owning your own local distributorship. We do 70% of the work! Unlimited \$ return. Investment required. Free call 1-844-225-1200.

#### DRIVERS

**EVERITT EXPRESS** New Pay Increase For Regional Drivers! 40 to 46 CPM + Fuel Bonus! Also, Post-Training Pay Increase for Students! (Depending on Domicile) Get Home EVERY Week + Excellent Benefits, CDL-A required. 1-888-362-8808 Apply @ [AverittCareers.com](http://AverittCareers.com) EOE - Females, minorities, protected veterans, and individuals with disabilities are encouraged to apply.

**ATTN DRIVERS:** Quality home time! Average \$1000 weekly. Up to 50¢ cpm BCBS+401K, pet and rider program. Orientation, and sign-on bonus. CDL-A required. 1-877-258-8782. [www.ad-drivers.com](http://www.ad-drivers.com)

**DRIVER TRAINEES NEEDED NOW!** Learn to drive for Werner Enterprises. Earn \$800 per week. No experience needed. Get your CDL and pre-hire now! 1-888-734-6710

**MARTEN TRANSPORT** South Central regional. Auto detention pay after one hour! Frequent home-time, earn up to \$1,100 week. CDL-A, 6 months experience required. EEOE/AAP 1-888-425-6374. [www.drive4marten.com](http://www.drive4marten.com)

**OWNER OPERATORS** Fleet drivers 2800-3200 miles/week average. ALL miles paid. Home every 6-8 days. Fuel surcharge paid plates, permits. 1-888-720-1565 [DriveParkway.com](http://DriveParkway.com)

**PAID CDL Training!** No experience needed. Stevens Transport will sponsor the cost of your CDL training. Earn up to \$40K first year and \$70K third year. Excellent benefits, 1-888-726-4130. [www.becomeadrivers.com](http://www.becomeadrivers.com). EOE

#### ENGINE REPAIR

**ENGINE REPAIR** Diesel engines: Powerstroke, Cummins, Duramax and more. Remanufactured with warranty and we deliver. Contact South Houston Engine, 1-713-918-5811 for more information.

#### HELP WANTED

**EARN UP TO \$500 a day.** Insurance agents needed. Leads, no cold calls, commissions paid daily and lifetime renewals. Complete training, health/dental insurance. Life license required. Call 1-888-713-6020.

#### TRAINING

**AIRLINE CAREERS** begin here. Become an Aviation Maintenance Technician. FAA approved training. Financial aid if qualified. Housing and job placement assistance. Call Aviation Institute of Maintenance, Dallas 1-800-475-4102 or Houston 1-800-743-1392

#### REAL ESTATE

**ABSOLUTELY THE BEST VIEW** Lake Medina/ Bandera, 1/4 acre tract, central W/S/E, RV, MH or house OK only \$830 down, \$235 month (12.91%/10yr). Guaranteed financing, more information call 1-830-460-8354

**ACREAGE REPO** with septic tank, pool, pier, ramp. Owner finance. Granbury 1-210-422-3013

**AFFORDABLE RESORT LIVING** on Lake Fork. RV and manufactured housing OK! Guaranteed financing with 10% down. Lots starting as low as \$6900. Call Josh, 1-903-878-7265

**20 ACRES, Ricksprings** Views, locked gate privacy. Native and exotic game. Rolling live oak, cedar terrain. \$2695 down, \$491/month (9.9%, 20 years). 1-800-876-9720. [www.ranchenterprisesltd.com](http://www.ranchenterprisesltd.com)

**\$106 MONTH BUYS** land for RV, MH or cabin. Gated entry, \$690 down, (\$6900/10.91%/7yr) 90-days same as cash. Guaranteed financing. 1-936-377-3235

**LOOKING TO SALE land?** Reach over 2-million readers for one low price in the Texas Statewide Advertising Network. Contact this newspaper or call 1-800-749-4793 for more detail.

**GET IN ON the great Texas land boom!** 2-5 acres ideally located just minutes from Fort Worth from \$39,900. Priced way below market in one of Texas's hottest and fastest growing markets. Utilities including water, great schools, more. Excellent bank & Texas Vet Financing. Call now! 1-866-952-5398, Ext. 82

**TEXAS HILL COUNTRY** drastically reduced. Private wooded home site, \$19,900. 18-hole golf course, lake Brownwood, resort style pool, new clubhouse. Financing available. 1-877-886-7576.

#### VACATION

**WEEKEND GETAWAY** available on Lake Fork, Lake Livingston or Lake Medina. Rooms fully furnished! Gated community with clubhouse, swimming pool and boat ramps. Call for more information. 1-903-878-7265, 1-936-377-3235 or 1-830-460-8354

#### Run Your Ad In TexSCAN!

Statewide Ad	\$550
290 Newspapers, 871,184 Circulation	
North Region Only	\$250
93 Newspapers, 297,505 Circulation	
South Region Only	\$250
97 Newspapers, 366,627 Circulation	
West Region Only	\$250
98 Newspapers, 209,950 Circulation	

To Order, Call this Newspaper direct or call Texas Press Service at 1-800-749-4793 Today!

NOTICE: While most advertisers are reputable, we cannot guarantee products or services advertised. We urge readers to use caution and when in doubt, contact the Texas Attorney General at 1-800-621-0508 or the Federal Trade Commission at 1-877-FTC-HELP. The FTC web site is [www.ftc.gov/bizop](http://www.ftc.gov/bizop)

Extend your advertising reach with TexSCAN, your Statewide Classified Ad Network.

Let the Big E work for you!

**PUBLISHER'S NOTICE:** All real estate advertising in this newspaper is subject to the Fair Housing Act which makes it illegal to advertise any preference, limitation, or discrimination based on race, color, religion, sex, handicap, familial status, or national origin, or an intention, to make any such preference, limitation, or discrimination. \* Familial status includes children under the age of 18 living with parents or legal custodians, pregnant women, and people securing custody of children under 18. This newspaper will not knowingly accept any advertising for real estate which is in violation of the law. Our readers are hereby informed that all dwellings advertised in this newspaper are available on an equal opportunity basis. To complain of discrimination, call HUD toll-free at 1-800-669-9777. The toll-free telephone number of the hearing impaired is 1-800-927-9275. CLASSIFIED AD RATES are \$8.00 for the first 15 words and 15¢ for each additional word. Special type-faces or boxes are extra. THANK YOU NOTES are \$10.00 for the first 40 words and 15¢ for each additional word. DEADLINES are 5:00 p.m. each Monday, subject to change for special editions and holidays. PREPAYMENT IS REQUIRED on all ads except for customers with established accounts. Visa and MasterCard accepted. ERRORS: Check your ad on its first printing. Errors not corrected within ten days of the first printing are the responsibility of the advertiser.

Follow us... to a website for all your local news.

# Clarendon LIVE.com

## Lees to lead women's basketball program at CC

Addie Lees had been selected to lead the Clarendon College women's basketball team.

Lees, a graduate of Plainview High School, was recently hired as head coach of the Lady Bulldogs and is most excited to work with the young ladies who are joining the basketball program this fall.

"I am also looking forward to working in the positive environment," Lees said. "There are many people on campus and in the community who support the athletic teams and coaches."

Lees started playing basketball in grade school and says she loved the challenge and truly wanted to improve her game.

"Each year I looked forward to attending Plainview High School, where it would count."

While at Plainview High, she helped lead the team to three state championship games, coming away with a pair of titles in 2002 and 2003 and runner-up in 2004.

"I played the point guard position," she said. "After high school I had the opportunity to play college basketball at Midland College."

After earning an associate's degree at Midland, Lees went on to play basketball at the University of Arkansas at Monticello. She earned a Bachelor of Arts degree in health and physical education at UAM, graduating Magna Cum Laude, and earned a Master of Science in Sport Administration from Eastern New Mexico University in 2011.

"My coaching career began immediately after receiving my bachelor's degree," she said. "I worked as a graduate assistant for two years



Addie Lees

at Eastern New Mexico University before becoming the assistant and then the Associate Head Coach at Howard College. I spent two seasons with the lady hawks before coming to Clarendon College."

Lees believes that both her playing and coaching experiences have most prepared her for this position.

"From a young age I always took something away from each coach," Lees said.

When asked who has inspired or mentored her, Lees said the person who has taught her much about basketball and running a program is the Head Coach at Howard College, Earl

Diddle.

"His knowledge of basketball cannot be compared to most," Lees said. "He's a phenomenal teacher of the game and has proven that over many decades."

She said Diddle gave her insight each season and set a great example.

"Coach Diddle brought a competitive spirit to every single practice and game," Lees said. "He gives his all to improving the skill of athletes both on and off the court. He gave me the opportunity of a lifetime, and for that I am forever grateful."

Clarendon College Athletic Director Brad Vanden Boogaard said Coach Lees comes to Clarendon with a background of the conference and region from her playing days and time as an assistant.

"Coach Lees is an energetic and confident individual," he said. "I feel she will be very demanding of our athletes and give them great guidance in representing our college on and off the court."

## USDA authorizes emergency grazing of CRP acres

Donley County USDA Farm Service Agency (FSA) Executive Director, Vance Killian has announced that Donley County was authorized for emergency grazing use of Conservation Reserve Program (CRP) acres for fiscal year (FY) 2014.

Unlike previous years, counties are not automatically approved for CRP emergency grazing when they reach the D2 (severe drought) level on the U.S. Drought Monitor. If there is a need for emergency grazing, each local FSA Office must request approval from the Texas FSA State Committee. Currently, 59 counties have received emergency grazing

approval. The 90-day emergency grazing period for these counties will end Sept. 11, 2014.

Based on a policy decision made by the Texas FSA State Committee, CRP acres grazed during fiscal year 2012 or 2013 will be considered eligible for emergency grazing if NRCS verifies, on a case-by-case basis, that the conservation cover will sustain grazing. FSA's fiscal year runs from October 1 to September 30.

"Eligible producers who are interested in emergency grazing of CRP must request approval before grazing eligible acreage and must obtain a modified conservation plan

from the Natural Resources Conservation Service that includes grazing provisions," said Killian. "Current provisions allow grazing on 100 percent of a field, up to the 75 percent stocking rate," he said.

There will be no CRP annual rental payment reduction for 2014 emergency grazing authorizations.

To take advantage of the emergency grazing provisions, authorized producers can use the CRP acreage for their own livestock or may grant another livestock producer use of the CRP acreage. The eligible CRP acreage is limited to acres located within the approved county.

Additionally, CRP land located

within the Lesser Prairie Chicken Crucial Habitat Assessment Tool (CHAT) zones I, II and III will only be able to practice managed or routine grazing, managed harvesting, emergency haying or emergency grazing one out of every three years. This frequency regulation resets in 2014, meaning that any land hayed or grazed in prior years that meets the available forage requirement according to NRCS standards will be eligible for emergency use in 2014.

For more information and to request approval for emergency grazing use of CRP acres contact the Donley County FSA office at 806/874/3561.

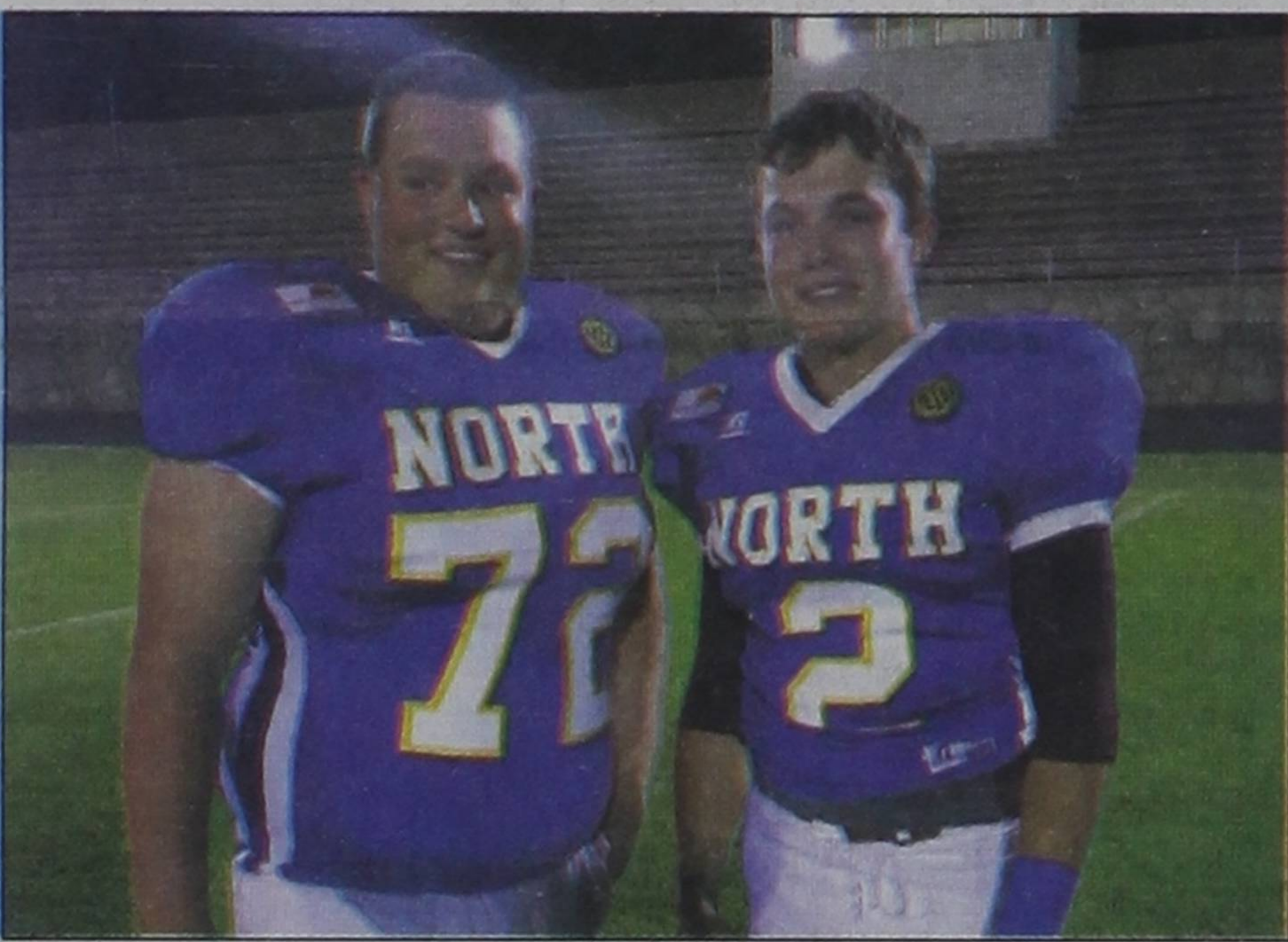

Tres Hommel and Chance McAnear participated and represented Clarendon in the Greenbelt Bowl in Childress June 10-14, playing on the North team. The final score was North 21- South 36.

COURTESY PHOTO / LAURA HOMMEL



Clarendon Junior Varsity basketball girls attended an Oklahoma State University basketball camp June 6-8 at Stillwater, Okla. The camp included teams from Kansas, Texas, and Oklahoma. Those attending were Hannah Hommel, Karlee Adams, Briley Chadwick, Briana Butler, Berkeley Alexander, Zaria Smith, Shaelyn Owiti, and Jensen Hatley.

COURTESY PHOTO / LAURA HOMMEL

### Subscribe Today

Donley County Subscription: \$30/yr.  
Out of County Subscription: \$40/yr.  
Out of State Subscription: \$45/yr.  
Enterprise-D Subscription: \$15/yr.

Call 874-2259 for more information

GLASSTECH

### WINDSHIELD REPAIR

Larry & Donna Hicks

Call Donna at

806-874-3108 • 806-205-1501

SEAL THAT CHIP BEFORE IT SPLITS!

### Buy ♦ Sell ♦ Trade ♦ Give Away

Joe's Flea Market  
Mon. ♦ Wed. ♦ Fri.  
at 9 a.m.

KLSR  
105.3 FM

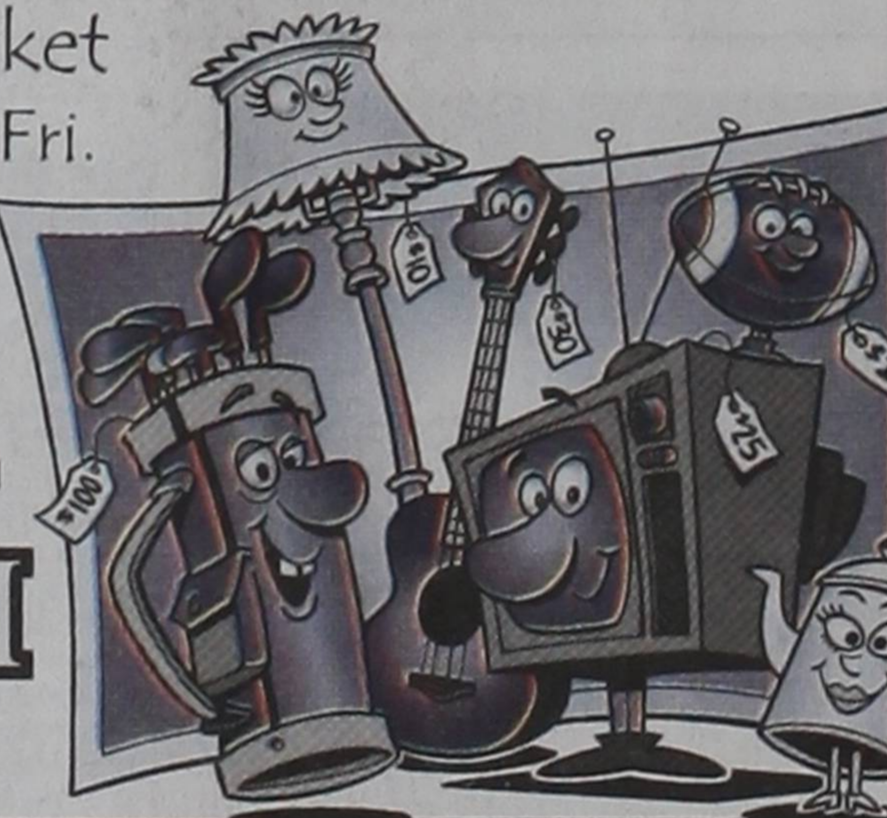

Bring the family to Henson's New

## Turtle Race

Register Daily at Hensons. Age groups 0 - 14....FREE  
Three \$50 cash prizes

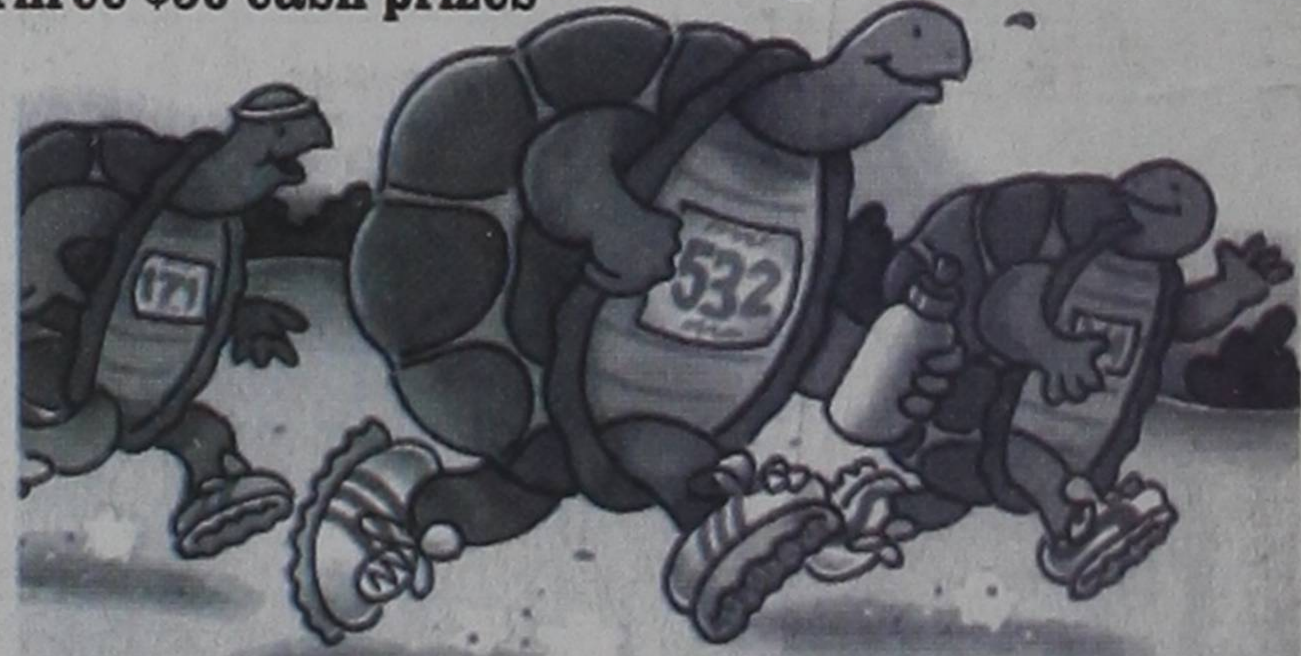

Sat., July 5 at 3 p.m. in  
downtown Clarendon

NEW Graduate Classes from 1950 - 2010....\$5.00  
1/2 of cash pot goes to winner & 1/2 to charity

WATER TURTLES WILL NOT BE ALLOWED TO RACE

9 am Iron Soldier Memorial Run  
2:30 pm Swearing In Ceremony for All Branches of Military  
5:15 pm Hourly Memorial Ceremonies  
1:15 pm Honor Guard

Visit WonderlandPark.com  
for a full schedule of events



June 28th

Join us  
at Wonderland!  
for Salute  
to Heroes

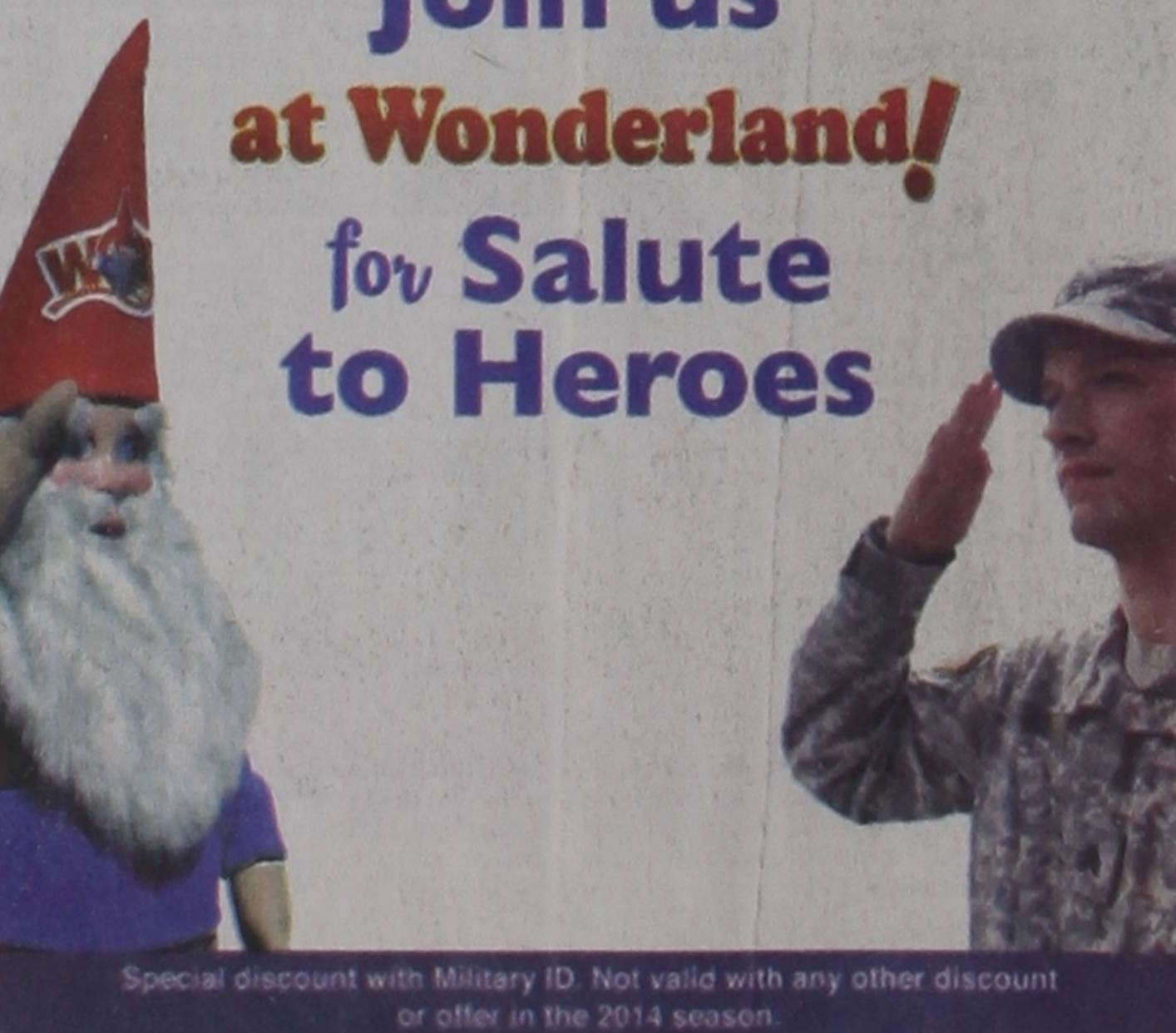

Special discount with Military ID. Not valid with any other discount or offer in the 2014 season.

## Please join the Clarendon Lions Club for a PLAYGROUND DEDICATION & RIBBON CUTTING

Thursday, July 3 - 11:30 AM  
Prospect Park  
Clarendon, TX

