



# THE CLARENDON Enterprise

THE CLARENDON NEWS & THE DONLEY COUNTY LEADER

CAR-RT LOT\*\*B 006 EXPIRES 5/15  
CLARENDON SCHOOL LIBRARY  
PO BOX 610  
CLARENDON TX 79226-0610

08.07.2014

The Texas Panhandle's First Newspaper.  
Established 1878.

www.ClarendonLive.com

Single Copy \$1.00

## THIS WEEK

- 2 Fred says its time for the feds leave one important issue to the states.
- 4 Members of the Ashtola and Martin communities plan for their last reunion.
- 5 A local church is holding a back to school clothing drive.
- 8 And see who won last week's softball tournament.

All this and much more as The Enterprise reports in this week's amazing edition!

## CC library to host storyteller Thursday

The Vera Dial Dickey Library at Clarendon College will present "Summertime Tales" with storyteller Bernadette Nason on Thursday, August 7, at 10:00 a.m.

Award-winning, awfully English actress/storyteller/writer/stand-up comedienne, Bernadette Nason, tours the US with wonderful traditional stories, adapted from the folklore of cultures from all over the world...and she's coming to Clarendon.

Close off your Summer Reading Program, "FIZZ, BOOM READ!" by coming to the library for an exciting, inter-active, hilarious program of Summertime Tales. Perfect for all ages but recommended for age 4 and up.

This program is funded by the Texas Commission on the Arts to bring live performance to rural Texas libraries.

## Student Council to host Fish Camp

The Clarendon High School Student Council is inviting all freshmen and new students to attend Fish Camp next Monday, August 11. Students will meet at the CHS Auditorium at 7 p.m. to play games, tour the school, and have snacks.

## Sales tax holiday is this weekend

Texas Comptroller Susan Combs reminds shoppers the annual sales tax holiday is scheduled for this Friday, Saturday and Sunday, Aug. 8-10.

The law exempts most clothing, footwear, school supplies, and backpacks priced under \$100 from sales tax, which could save shoppers about \$8 on every \$100 they spend during the weekend.

Lists of apparel and school supplies that may be purchased tax free can be found on the Comptroller's website at www.TexasTaxHoliday.org.

This year, shoppers will save an estimated \$82.7 million in state and local sales taxes during the Sales Tax Holiday.

The tax holiday weekend has been an annual event since 1999.

## School supplies to be distributed Friday

Three local groups have teamed up to ensure that no kid goes without the tools they need to succeed this school year.

The The Lila Kate Monroe Memorial Fund, the First United Methodist Church and Christ's Kids Ministries will offer free basic school supplies on Friday, August 22, at the Christ's Kids Ministry Center, 416 S. Kearney, from 1:30 to 3:30 p.m.

## Shot clinics to be held during August

The Texas Department of State Health Services will hold three Immunization Clinics in Clarendon August 7, 14, and 21 from 8:30 to 11:30 a.m. and from 1:00 to 3:30 p.m. at the TDSHS office at Five Medical Drive with the first 15 clients being seen.

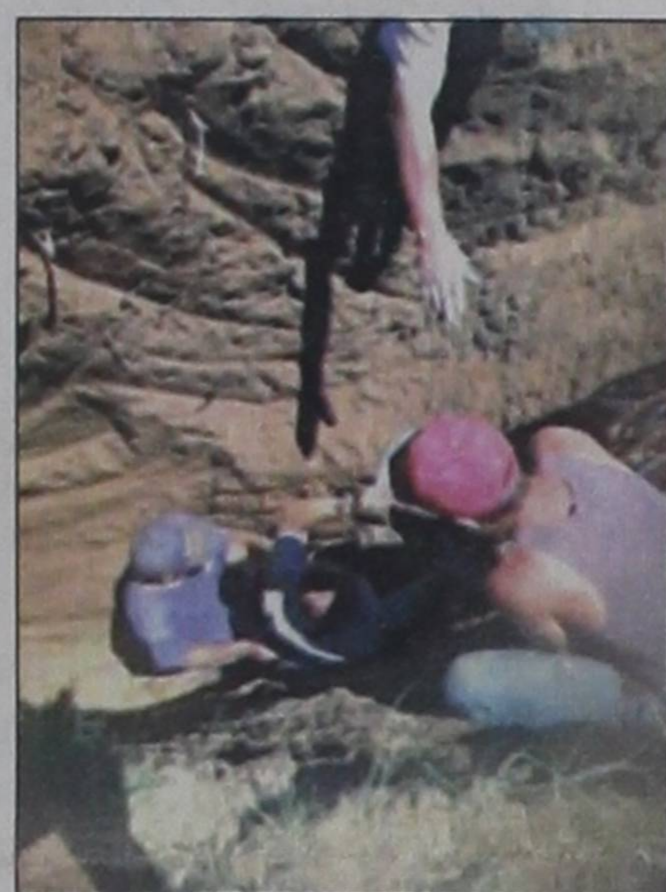
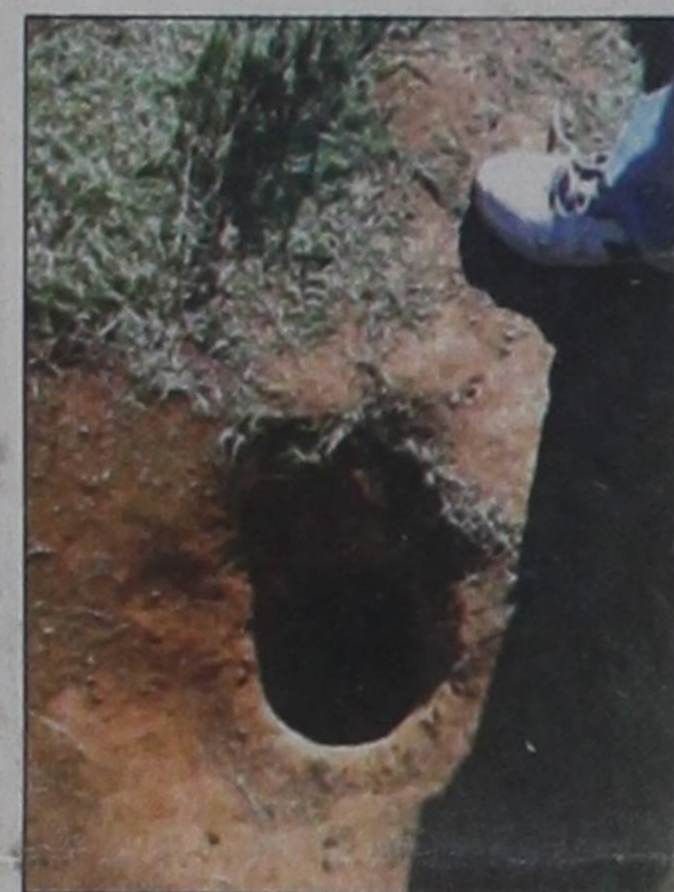

Jim Whitlock holds his beloved pet, Sophie, Tuesday morning (top photo) after the Yorkie spent 27 harrowing hours in a 15-foot well hole last week.

ENTERPRISE PHOTO / ROGER ESTLACK & COURTESY PHOTOS / JOHN MORROW

# Saving Sophie

By Roger Estlack, Clarendon Enterprise

Despair turned to joy last week when a local family's pet was rescued from a well hole after 27 hours.

The 15-year-old Yorkie named Sophie began an ordinary day last Wednesday, July 30, with her owner Jim Whitlock, putting out feed on the old Reynolds place five miles south of Clarendon on the JA Ranch Road.

That was at 10 a.m.; and when Whitlock got ready to leave, Sophie was nowhere to be found.

"She was always with me and usually stuck close to me," Whitlock said. "When I couldn't find her, I thought she might have chased a rabbit."

The search was on with Whitlock and his wife, Sue, joined by Troy Ritter and Tye and Cortney Jackson diligently looking for Sophie.

Finding her was imperative. This was more than a dog to the Whitlocks. This was their family.

"We lost a daughter in 1960 to a drunk driver," Whitlock said. "So we don't have any kids or grandkids. We just have our animals."

And Sophie, along with her sister, had been Whitlock family members for eleven years.

As the search wore on more than half a mile away, Sue Whitlock convinced her husband that there was no way Sophie had wandered that far off.

"We went back to the windmill, and as I got to the other side of it, I saw that hole. A shiver went up my spine," he said.

The hole was 15 feet deep, nine to 10 inches in diameter at the opening but narrowing to about four inches at the bottom.

"I thought 'surely not,' but I hollered her name, and she barked from the bottom of hole."

As the Whitlocks' hearts sank, they were joined by other friends and neighbors over the next several hours - R.J. Kemp, John Morrow, Tanner Morris, Kelly and Linda Hill, Kelly and Vicki Tunnell, and others - as numerous methods were tried to pull Sophie from the well.

Morrow put a camera down the hole that showed it was walled at the bottom, and that Sophie was off to one side.

"We were trying to get a noose on her," Whitlock said. "We got her front legs in, but we couldn't get her through the small part of the hole."

Next, they devised a hook that successfully snared Sophie's collar and brought her up in the hole. But about five feet up, the collar slipped off, and she fell back to the bottom.

The Whitlocks, joined by Mrs. Tunnell, turned to prayer to guide the rescuers.

"I prayed out loud, and she would come over and we would pray some more," Whitlock said.

But at 2:30 Thursday morning, Whitlock decided it was time to stop for the night.

"I called it off," he said. "Sophie was tired. We were all tired. We needed to rest."

Sophie remained on everyone's minds throughout the night, and Morrow had a realization that would prove the key to saving her life. Nooses and catches were too risky and

might harm the dog, but Morrow knew what needed to be done.

"John called me the next morning and said we were going to save her just like that girl in the well," Whitlock said.

In 1987, eighteen-month-old Jessica McClure fell down a 22-foot well near Midland. Rescuers ultimately saved her by digging a parallel hole to the well and then tunneling to her. Morrow felt the same method would work with Sophie, and he brought his backhoe to the site and began to dig.

Ten feet was the limit of his equipment, so Chris Schollenbarger joined the effort with a trackhoe that could continue to get the last five feet. Then the tunnel was dug to get to Sophie.

At first she would stick her head up but not come out. Then Kelly Hill was able to get her out and relief flooded their emotions.

"I bawled like a baby," Whitlock said. "I just love her."

The Whitlocks are forever grateful to the people who rescued their loved one. For her part, Sophie is safe, healthy, and happy. But now she stays not more than about three feet from her owner's side.

"We got her back through a bunch of great people and prayer. A lot of good people showed up and no money was exchanged," Whitlock said. "We owe a big thanks to everyone who helped."

Morrow urges everyone remember the need and responsibility to plug, cap, or seal, abandoned well holes to prevent tragedies.

## Back to basics

Clarendon ISD Athletic Director Gary Jack directs plays Tuesday morning as the Clarendon Broncos began working out for the 2014 football season. The Broncos will scrimmage Bovina here next Friday, August 15, and the regular season begins August 29.

ENTERPRISE PHOTO / ROGER ESTLACK



## Regents consider FY '15 budget

Clarendon College Regents began work on a \$9.1 million projected budget for fiscal year 2015 during a called meeting last Thursday, July 31.

The budget is forecast to be less than the current expenses, and CC President Robert Riza said the administration's numbers are based on statewide projections of no growth in college enrollments.

"The new norm is zero and down for enrollment," Dr. Riza said, noting that the plentiful availability of jobs in the economy makes it hard to recruit students for college.

College officials plan to adopt an ad valorem rate in the Clarendon College District, which covers all of Donley County, set at \$0.220802 per \$100 valuation, which is lower than the current tax rate of \$0.222732. However, due to higher property values, the lower rate will actually bring in about \$31,000 in increased revenue.

The proposed rate is eight percent higher than the effective rate of \$0.204447, the rate which would bring in the exact same revenue as last year.

Regent Tex Selvidge spoke in favor of adopting the proposed rate, noting that it was better to raise taxes a little when times are good than to get behind and have to raise them a lot. Other board members also agreed with Selvidge.

CC won't be looking at any tuition increases, and Riza said state appropriations will remain unchanged. The college is expecting to receive about \$100,000 more from the five-cent tax in Gray County due to higher values there.

The 2015 budget will be condensed compared to the current budget, Riza said, and it will be easier to track expenses and related programs.

Thursday's workshop did not include any information about the college's auxiliary budget, which covers expenses for athletics, the bookstore, and cafeteria operations. Regents will hold a public hearing and continue budget talks on August 14 and are set to adopt a tax rate that day as well.

In other college business, Riza gave Regents their first look at the administration's strategic plan being developed for 2014-2017, labeled "One College...One Vision."

When finished, the plan will take the college through its upcoming reaccreditation process and also has goals to redesign and increase student services, implement a district-wide master plan, strengthen college-community relations, and identify programs for expansion.

Regents also met in closed session to discuss personnel, but no action was taken following the closed session.

**ENTERPRISE STAFF**

**Roger A. Estlack**  
Publisher & Editor

**Ashlee Estlack**  
Contributing Editor

**Tara Hogan**  
Office Director

**Morgan Wheatly**  
Ads & Layouts

**CORRESPONDENTS**

**Peggy Cockerham**  
Howardwick

**Sandy Anderberg**  
Clarendon Sports

**Fred Gray**  
Featured Columnist

**Karl Lindsey**  
Photographer

**Matthew Martinez**  
Photographer

**Kathy Spier**  
Hedley

**CONTACT INFORMATION**

Phone  
**806.874.2259**

Fax  
**806.874.2423**

E-Mail  
**news@clarendononline.com**

Web Site  
**www.ClarendonLive.com**

**ADVERTISING**

Open Display rates are \$5 per PASS column inch. Classified Ads are \$10 for the first 15 words and 15¢ per word for each additional word (Boxes or special typography are extra.). Thank You Notes are \$15 for the first 40 words and 15¢ per word for each additional word. Basic engagement, wedding, anniversary, and birth announcements are \$10 each. Expanded wedding announcements are \$20. A one-column announcement picture is \$5, and a two-column announcement picture is \$10. Pictures submitted for publication should be picked up within ten days after publication. Death notices are printed at no charge. Obituaries are published for \$45 or \$50 with a photo.

**DEADLINES**

News articles and photos are due by Monday at noon. Advertising and Classifieds are due by five o'clock Monday afternoon. Deadlines may be altered for holidays or special issues.

**SUBSCRIPTIONS**

Annual subscriptions are available for \$30 for zip codes inside Donley County, \$40 elsewhere in Texas, and \$45 out of state. **POSTMASTER:** Send all address changes to: **The Clarendon Enterprise**, PO Box 1110, Clarendon, TX 79226-1110. **Digital Subscriptions** are \$15 per year.

**LETTERS**

Letters to the editor are welcome. Views expressed in letters are those of the writers and do not necessarily reflect the views of the editor or staff of **The Clarendon Enterprise**. Submission of a letter does not guarantee publication. Letters may be edited for grammar, style, or length. All letters must be signed and must include an address and telephone number for verification. To improve your chances of publication, type and double space your letter, stick to one main topic, and keep it brief. No letters will be accepted from candidates for local political offices. Letters submitted to this newspaper become the property of **The Enterprise** and cannot be returned.

**The Texas Panhandle's First Newspaper**

**THE CLARENDON NEWS**, established June 1, 1878 with which have merged: **The Clarendon Traveler**, February 1889; **The Clarendon Journal**, November 1891; **The Banner-Stockman**, October 1893; **The Aftator**, February 1899; **The Clarendon Times**, May 1908; **The Donley County Leader**, March 12, 1929; **The Clarendon Press**, May 18, 1972; and **The Clarendon Enterprise**, March 14, 1996.

**Member 2014**



National Newspaper Association



Texas Press Association



West Texas Press Association



Panhandle Press Association



**Repeal federal ban on marijuana**

The Federal government should repeal the ban on marijuana.

'Tis true, Congress needs to repeal the federal ban on marijuana use, for both medicinal and recreational purposes. According to a recent New York Times editorial, "nearly three-quarters of the states have experimented with legalizing medicinal uses of marijuana, reducing penalties, or even simply legalizing all use." The Times added, "There are no perfect answers to people's legitimate concerns about marijuana use. But neither are there such answers about tobacco or alcohol, and we believe that on every level — health effects, the impact on society and law-and-order issues — the balance falls squarely on the side of national legalization. That will put decisions on whether to allow recreational or medicinal production and use where it belongs — at the state level."

Even the brilliant conservative intellectual, William F. Buckley, encouraged Congress to repeal the ban on marijuana, postulating that the individual states should determine whether or not pot use should be legalized. Most libertarians agree with Buckley's postulation. This issue needs to be decided individual states, reflecting local sentiments.

Also, conservative commentator David Brooks thinks the federal law should be taken off the books. He advocates that marijuana use should not be a criminal offense.

Yours truly agrees, even though I have not had excellent experiences with the devil weed. You see, many years ago, including an occasion not as many years ago, I inhaled — several times. Bad idea! A few minutes after inhaling, I was struck dumb and experienced an almost comatose state of mind. All I could do was sit in a corner and stare into space. I could not move. Actually, I could barely sit up straight. In short, I have absolutely no tolerance for the devil weed; it encourages me to embrace my toilet.

I later considered that perhaps first experience could have been some sort of aberration, and that perhaps I should try one more time — just to make sure. Sure enough, inhaling once again resulted in

another comatose stupor.

Furthermore, that second time I was overwhelmed with nausea and vertigo. I quickly learned that if I wanted to enjoy my mind and life then my marijuana use was going to have to go.

My casual use of marijuana did go — for about two score years. Being obtuse, I inhaled one last time. Shortly thereafter, my blood pressure dropped precipitously and I knew that I was in serious trouble. A deathly pallor came over me and I knew that I was on the brink of death. To this day, I remain convinced that the use of marijuana will kill me deadlier than the dinosaurs. It is simply not for me.

However, my experiences with the devil weed are vastly different than other peoples' experiences. They should be able to decide whether or not they want to risk their lives and freedom to use this herb. As we all know, Colorado and Washington recently passed recreational use laws. It will take a while to see how things go with these two experiments.

Things have not gone so well for a Montana grower, however. Not long ago the feds raided a medicinal use grower, who was in full compliance with Montana state laws. When the feds conducted the raid, the grower was taking his kids on a hunting trip and there were four rifles in his truck when the raid commenced. Therefore, four counts of firearms violations were tacked on to the charges, and the grower was sentenced to 80 years in federal prison. Even though his sentence was later reduced to eight years, it is wrong that he must serve any time whatsoever, since he was in full compliance with his state's laws. They also torched his business — actually burnt his crop to the ground.

Even though marijuana users and producers may be in full compliance with their respective state laws, they

must be made aware that they are in violation of tough federal laws and are subject to very long prison sentences. Depending upon which presidential administration is in office, and the vicissitudes of various federal prosecutors, federal law enforcement will vary widely. People who value their freedom and treasure should contemplate long and hard before deciding to violate federal marijuana possession statutes.

Of course, there is another federal law on the books, which states that every federal government employee must immediately denounce any positive statement on marijuana use. Therefore, as long as this law is on the books, there can be no open debate on federal marijuana laws. This law must first be taken off the books if we are to have an honest and intelligent discourse on this issue.

Now, personally, I don't care if marijuana is legal or illegal. My inhaling days are long past, and I will never repeat my past actions, lest I inadvertently cause my final viewing to occur much sooner than I wish. Marijuana is not good for me personally. This is probably true for many people. However, there are many others who disagree. Therefore, the decision should be made by the voters in individual states, not by the federal government.

Currently, according to several polls, 52 percent of the American public are for legalizing marijuana, either medicinally or recreationally. They consider it to be a states' right issue. I agree. Let the states decide, and leave the federal government out of it. They have a long "to do" list to screw up.

Considering that the moderate use of marijuana poses no significant health risk at all — for healthy adults, and apparently doesn't cause cancer let the voters decide its ultimate fate. Of course, kids and adolescents below the age of 21 should never smoke pot.

Individual states must decide this issue, not the federal government. Texans should make their own decision in this matter, at the ballot box, not through the courts, which are overwhelmed with other, more significant issues.



**the quick, the dead, & fred**  
by fred gray

**We have the Congress we deserve**

The US House of Representatives last week voted to sue President Barack Obama, claiming the chief executive has overstepped the limits of his powers.

The Republican-led House doesn't like the way Mr. Obama enforces some laws and not others, and they specifically don't like the way his administration has chosen to enforce parts of the Affordable Care Act (also known as Obamacare) but not enforce other parts of the same law.



**editor's commentary**  
by roger estlack

They have a point, and this column largely believes the GOP is right to be upset with the president on this. However, a lawsuit doesn't seem like a very good way to handle things.

The House's most effective tool remains its control of the purse strings, and they should pull those strings tight every chance they get, effectively strangling any Obama program they don't like. Congress putting on the breaks is probably the only way we'll ever get the shackles back on our government.

Expectations of Congress doing anything right isn't too high right now. In fact, CNN posted an online story Tuesday with the results of an informal poll. They asked their followers on Facebook and Twitter to describe Congress using only one word. More than 5,000 people responded, and "useless" was the number one response, followed by "worthless" and "joke."

And it didn't get any better after that. The next seven most popular responses were "corrupt," "incompetent," "lazy," "inept," "idiots," "selfish," and "dysfunctional."

A word cloud — a graphic representation of the most popular words — showed virtually no positive responses to the question. And some words made the top ten look like compliments. Consider these responses: "criminals," "traitors," "crooks," "losers," and "crap."

The article quotes a NBC News/Wall Street Journal/Marist College poll this week that reports only three percent of voters as considering Congress "productive," and another poll showing Congress with a 15 percent job approval.

Who are these 15 percent that are pleased with Congress? They need to have their heads examined and their voter registration cards taken away.

Typically, individual Congressmen and Senators get high marks from their constituents. The old "I hate Congress but love my Congressman" phenomenon has been prevalent for years in politics. However, CNN says the Washington Post reported that 51 percent of people now disapprove of their own representative's job performance.

Results for individual members of Congress weren't available, but I suspect that our own Mac Thornberry still enjoys a pretty high approval rating by Texans in the 13th District. He shares our values and votes the way most of us probably want him to. Your editor disagrees with Mac occasionally, but largely thinks he's doing the best he can in a corrupt and broken system.

As a body, Congress is out of touch with the people it represents, has no qualms about ignoring the Constitution unless they want to beat the president over the head with it, and mostly serves to spend money we don't have to fund a government that generally only makes life more difficult and more expensive.

You can blame it on gridlock if you like. You can point to the fact that Republicans don't like Democrats and vice versa or that things are more polarized that ever in Washington. But the fact of the matter is things don't seem to get better whether we have united government or divided government. The government itself is the problem.

Obama had his time with his party in control of both houses of Congress, and yet nothing much was accomplished other than a poorly written health care law that causes more problems than it solves. George W. Bush had his time with his party in power, and yet there were no great strides in rolling back government. The last Bush administration was a study in lost opportunities and, unfortunately, lost freedoms.

Some say that term limits are the answer to this vexing problem. A House full of inexperienced Congressmen, however, would put all the power in the hands of entrenched Congressional aides. The same thing has happened with the executive branch where bureaucrats are running the show largely without the president's knowledge or permission.

The quality of our Congress and our White House won't get any better until the people demand it. But the people, for all their supposed frustration, are largely indifferent to Washington. And that is the biggest problem.

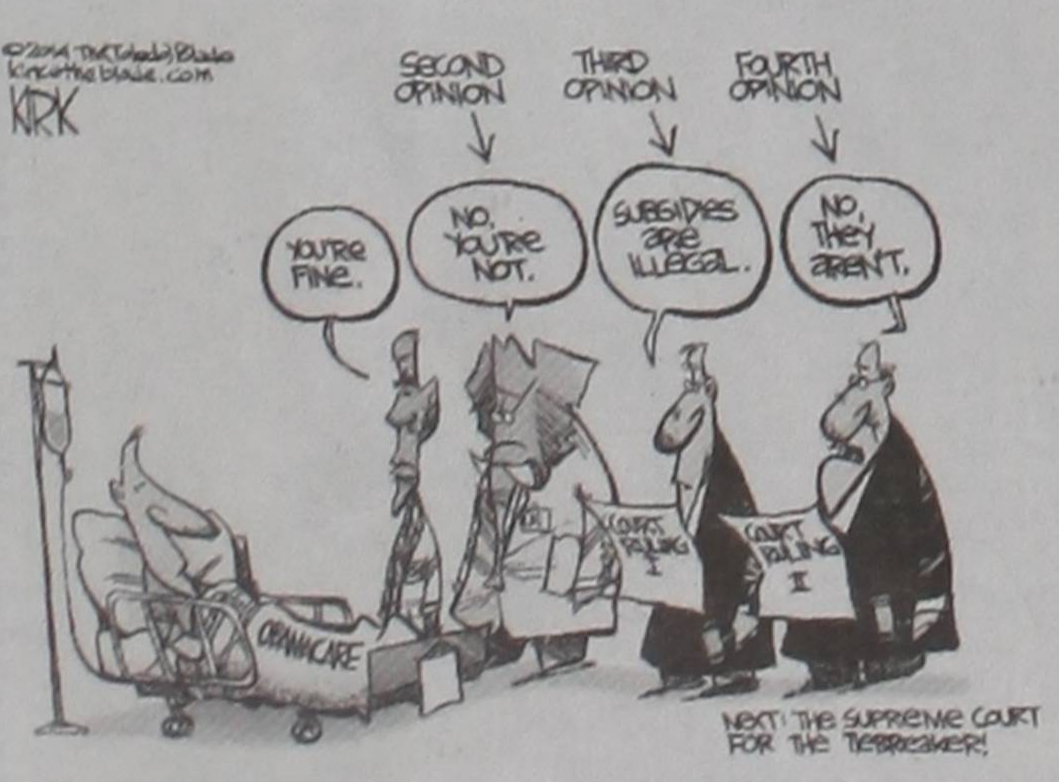

**Life through oil-coated glasses**

Oh, No! Say it isn't so. My Uncle Mort, who usually doesn't stay on a single subject long enough to muster a significant "peeve," is speaking to me again. He's mighty disappointed that I didn't mention — "privately or in print" — his July 4 birthday.

"The date has passed and the whole blamed month is gone, too," he added, whimpering lamely that he's "trying to get over it." (I've heard he's been accusing me of "routinely writing of lesser things" than his 102nd birthday, and that whether he's a "real" person — or a figment of my imagination — "really shouldn't matter.")

I mumbled apologetically, biting my tongue to avoid speaking of a "real" friend whose age is closer to 104 than 103. His name: H. Bryan Poff, who still makes oil and gas deals daily from his modest home in east Fort Worth....

Mr. Poff gave up driving a decade or so ago, but drilling? He's still at it, now in his ninth decade of petroleum exploration. He's known for his unshakable faith, bright mind, keen memory and rich first-hand experiences in Texas' major oil fields — save one. He missed out on Spindletop — the forerunner of state-wide drilling that blew in between Beaumont and Port Arthur in 1901 — one decade before the old wildcatter was born.

With a hearty laugh, quick-triggered smile and incurable optimism, Poff is forever bold, and the Holy Bible would be home plate if his Christian pilgrimage were a game. He claims

"mother's knee" teachings — many from Philipians — and his ongoing daily Bible study — often in Proverbs — to be foundational.

He's experienced all of the "ups and downs" of exploration. "I'm happy for my share of dry holes, because they make 'hits' even sweeter," Poff claims....

He's a "living encyclopedia" of Texas' petroleum history, citing "chapters and verses" of major events — and some not so major. Files, documents, clippings and photographs surround his big recliner, where he now spends most days. A telephone — usually warm — is within arm's reach.

Poff is now perusing mounds of material — some yellowed with age — begging to be passed along...or tossed. "I'm sending you some items you might like," he mentioned as casually as a Texas tourist might describe Gibraltar as "a good-sized" rock....

Sure enough, the mail soon brought an old clipping from the Fort Worth News-Tribune. In vivid detail, it recounted newspaper coverage of a remarkable 1920 Fort Worth funeral attended by more than 50,000 people when the city's population was only 103,000.



**the idle american**  
by don newbury



## Wood, Gage win Jack and Jill tourney

Golfers Kevin Wood and Ouida Gage teamed up to win the annual Jack and Jill Tournament at the Clarendon Country Club last weekend over a field of nineteen teams.

The couple shot a 69-66 for a 135 in the two-day, thirty-six hole, best ball tournament.

Mark and Leighann Ward tied with Kyle and Kenna Hatch for second place with a total of 137, which was won by the Wards in a playoff.

Joe and Karla Minkley won the first flight with a 138 and Redell and Sherol Johnston won second with a 142. Russell King and Mary Ann Sawyer split third place with Donald

and Judy Bland with a 143.

Todd Curry and Jennifer Clark won the second flight with a total of 148, and Gene and Gayle Rogers won second at 149. A three-way tie for third resulted in a card playoff that was won by the team of Bruce and Lea Ferguson with a total score of 154. The duo won over Mark and Sunday Morris and Larry Maxwell and Debra Kincaid.

Mark Morris won closest to the pin on number 15 at 25', and the longest putt went to Steve Jackson at 9'1".

Sherol Johnston won low gross in the weekly women's game on Thursday with an 83. Mary Ann

Sawyer and Gayle Rogers tied for low net with a handicapped score of 73. Two teams tied for the top spot in the Friday night scramble at four under par. After a two-hole putt, off the team of Mike Santos, Collin Edwards, Tracy Duncan, and San West defeated the team of P.J. Lemons, Russell King, and Gayle Rogers.

There will be an 18-hole night scramble Saturday, August 16, beginning at 6:00 p.m. Nine holes will be played in the light of the day and the remaining nine holes will be played after dark with glow-in-the-dark equipment. You may call the Pro Shop to enter.

## Sheriff Blackburn attends Sheriffs' Association of Texas conference

Donley County Sheriff Butch Blackburn recently attended the Sheriffs' Association of Texas 136<sup>th</sup> Annual Training conference at the Henry B. Gonzalez Convention Center in San Antonio, July 26-29, 2014. Over 1,500 were in attendance.

The first Sheriffs' Association of Texas Conference was in 1878. Held annually in various cities across the state, this event allows Sheriffs, Deputies, Federal, State, and City Law Enforcement Officers to network and discuss different issues that affect law enforcement across the state and nation. This year,

participants received training in a variety of topics including: Crimes in Texas/Border Violence, Criminal Profiling, Homicide Investigations, Mental Health Issues in Jails, Active Shooter Response, State Agency Updates, Public Safety Broadband Program, School Safety, Legislation, Policies, Civil Process, and Human Resources. Participants also had the opportunity to familiarize themselves with the latest in crime fighting tools and technology at more than 200 exhibitor booths.

The Sheriffs' Association of Texas (SAT) is a 501c3 non-profit

organization dedicated to increasing the effectiveness of local law enforcement in Texas. Through the support of their members, SAT provides training, Legal/technical information, and other critical resources to Peace Officers in Texas. SAT also offers college scholarships to Peace Officers and their children who wish to continue their education. In addition, they honor Fallen Officers with their Lost Lawman Memorial. For further information on the Sheriffs' Association of Texas and how to join as an associate member, visit [www.txsherrifs.org](http://www.txsherrifs.org) or call (512)445-5888.

**Be Loyal. Buy Local.**  
Support the merchants who support your community.

**4-M**

## DRILLING

IRRIGATION, DOMESTIC, TEST HOLE  
GOULDS AND SIMMONS PUMPS

JOE MORROW, OWNER  
P.O. Box 701 CLAUDE, TX 79019 806.226.5023 806.681.7150

## Top 9 Rodeo Series

# TOP O' TEXAS RODEO

August 7, 8, & 9



### Thursday August 7

Free BBQ for all ticket holders

7:00 pm

TCRA Top O' Texas Rodeo

### Saturday August 9

7:00 am

Giddy Up and Run 5K registration  
Downtown Pampa

10:30 am

Top O' Texas Rodeo Parade  
Downtown Pampa

4-6 pm

BBQ Cook Off  
Recreation Park

7:00 pm

TCRA Top O' Texas Rodeo

9:00 pm

Dance Featuring -  
Jake Moffat Band

Couples Night

### Friday August 8

7:00 pm

TCRA Top O' Texas Rodeo

Family Night - Special discount on tickets

9:00 pm

Dance Featuring -  
Young Country

Ladies Night

#### Tickets

\$10 adults, \$5.00 kids 5-12 and kids 4 & under free

#### Each Rodeo Night Features

Calf Scramble, Dollar Drop, Mutton Busting, Donkey Riding, and Jr. Barrels

#### August 9th

#### Downtown Activities

Turtle Race, Bicycle Race, Vendors, Hot Dog Eating Contest sponsored by Coney Island

#### Recreation Park Activities

Vendors, Live Music, Kids Activities, Horseshoe Tournament sponsored by Wayne's Western Wear

**PAMPA Chamber of Commerce**  
669-3241 • [www.pampachamber.com](http://www.pampachamber.com)



"Everything under one roof!"

# THE CLARENDON OUTPOST

US 287 WEST • CLARENDON, TEXAS

CALL: 874-5201 • OPEN DAILY 6 A.M. TO 10 P.M. • PHARMACY: 874-5202

AD GOOD THRU: July 14, 2014

OUTPOST PHARMACY  
WELLNESS CENTER

Sign up for a free monthly supply of children's vitamins.

Probiotics, Vitamin D, Vitamins and fish oil boost immune systems. Get your student started on a healthy regime to keep them healthy.

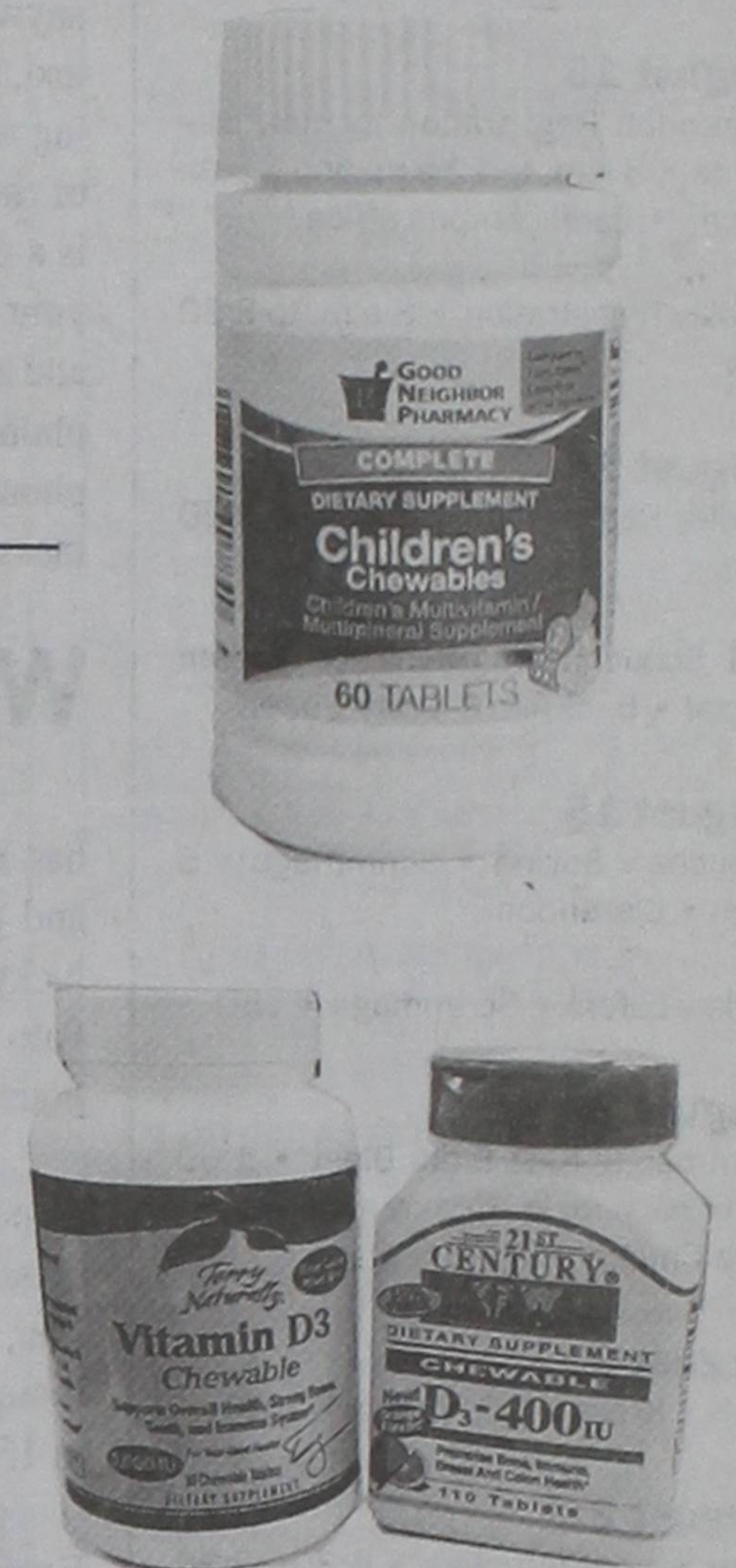

Come get your school supplies!

Forget the hassle of school supply shopping & get everything you need in one bag!



## fabYOUlous

Back-to-School Fashions

Keep it cute from the first day to the last, with big deals on hot looks for the new school year!



Dresses • Jewelry • Purses

## Shadow Warriors

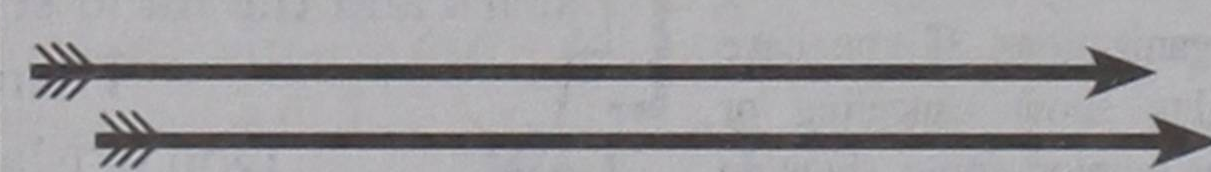

Artist: Mary Selfridge

Size: 18 x 24 Media: oil on canvas



OUTPOST DELI  
THIS WEEK'S SPECIAL

Quench your thirst with one of our Blended Iced Coffee & Smoothies



★  
**¿Qué Pasa?**  
Community Calendar

**August 11**  
Clarendon Registration for enrolled students • 6 p.m. to 9 p.m. • Cafeteria

Hedley Pre-Registration Picnic • 5:30 p.m. to 7:30 p.m. • Cafeteria

**August 12**  
Clarendon Registration for enrolled students • 6 p.m. to 9 p.m. • Cafeteria

Hedley Registration • 8 a.m. to 3:30 p.m.

**August 13**  
Clarendon Registration for new students • 8 a.m. to 12 p.m. and 1 p.m. to 4 p.m. • Each campus office

Hedley Registration • 8 a.m. to 3:30 p.m.

**August 14**  
Hedley Registration • 8 a.m. to 3:30 p.m.

Girl Scout Recruitment Ice Cream Social • 5 - 6 p.m. • Dairy Queen

**August 15**  
Broncos v Bovina • Scrimmage • 5 p.m. • Clarendon

Owls v Lefors • Scrimmage • TBD

**August 20**  
Community Kidz Bible Blast • 1:00 to 6:30 p.m. • Community Fellowship Church

**August 21**  
Owls v Kress • Scrimmage • TBD

**August 22**  
Free School Supplies • 1:30 - 3:30 p.m. • Christ's Kids Ministry Center

Broncos v Electra • Scrimmage • 6 p.m. • Electra

**August 25**  
Back To School

**August 29**  
Broncos v Tulla • 7:30 p.m. • Tulla

Owls v Higgins • 7:30 p.m. • Hedley

**September 1**  
Labor Day

**September 5**  
Broncos v S-Earth • Homecoming • 7:30 p.m. • Clarendon

Owls v Lefors • 7:30 p.m. • Lefors

**September 7**  
Grandparents Day

**September 11**  
Patriot Day

**September 12**  
Broncos v Highland Park • 7:30 p.m. • Clarendon

Owls v Vernon Northside • 7:30 p.m. • Vernon

**September 19**  
Broncos v Gruver • 7:30 p.m. • Gruver

Owls v Valley JV • 7:30 p.m. • Hedley

**September 26**  
Broncos v Booker • 7:30 p.m. • Booker

Owls v Lazbuddie • 7:30 p.m. • Lazbuddie

**October 3**  
Owls v Harrold • 7:30 p.m. • Hedley

★  
**Menus**

August 11 - 15

**Donley County Senior Citizens**  
Mon: Breaded chicken tenders, bakers potatoes, carrot raisin salad, wheat bread, strawberry short cake, iced tea/2% milk.  
Tue: Navy beans w/ham, sweet potatoes, turnip greens, cornbread, apple cobbler, iced tea/2% milk.  
Wed: Mexican pile on, Spanish rice, pinto beans, tortilla, brownie, iced tea/2% milk.  
Thu: Smothered steak, mashed potatoes, mixed greens, wheat roll, angel food cake/peaches, iced tea/2% milk.  
Fri: Sloppy Joes on bun, baker potatoes, corn, melon medley, iced tea/2% milk.

**Hedley Senior Citizens**  
Mon: Chicken spaghetti, buttered carrots, zucchini, wheat bread, banana pudding, iced tea/2% milk.  
Tue: Meatloaf w/sauce, mashed potatoes, mixed vegetables, rolls, apple fluff, iced tea/2% milk.  
Wed: Roast beef, baked potato w/ sour cream, buttered carrots, roll, chocolate pudding, iced tea/2% milk.  
Thu: Oven fried chicken, pasta, broccoli/raisin salad, fruit cocktail, iced tea/2% milk.  
Fri: Turkey & dressing, candid sweet potato, green beans, roll, pineapple tidbits, iced tea/2% milk.

**Gift card scam signs up victims for charges**

Hi, gang! We have another way the scammers try to get our hard earned money.

If you have a cell phone, you've probably gotten one. The "You've Won a Free Gift Card" spam text messages are so common, you may not think anything of them. But be careful, responding to those texts could accidentally sign you up for a \$9.99/month charge.

How the Scam Works: You get a text message saying that you just won a \$1,000 gift card from a major retailer. It sounds too good to be real, but you decide to check it out anyway. You follow the link in the text, and it leads to a legitimate-looking website with the colors and logo of the real company. On the website is a form that prompts you to "claim your prize" by entering your name and address and confirming your cell phone number. When you enter your phone number, you receive a text message with a secret PIN. You type

the PIN into the form and hit submit. Your gift card is on the way... or not!

There is no gift card, and "winners" found themselves unknowingly signed up for \$9.99 per month premium text messaging service. The scam, known as cramming, happens when a company uses your cell phone bill like a credit card, adding a charge for services that you never knowingly purchased. This scam is so prevalent that the FTC got involved and shut down six providers. What Can I Do About Cramming? Just hit delete! Receive a suspicious text message? Ignore instructions to confirm your phone number or visit a link. Other scam text messages instruct you to text

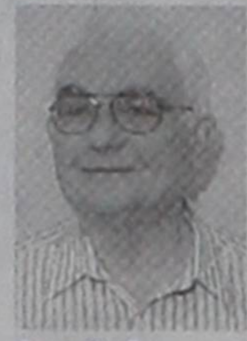

**bob's whittlin'**  
by bob watson

"STOP" or "NO" to prevent future texts. But this is a common ploy by scammers to confirm they have a real, active phone number.

Read your phone bill: Check all charges on your phone bill each month for products and services you haven't ordered. Some charges may appear only once, but others might be monthly "subscriptions." Pay special attention to sections labeled "Miscellaneous," and the "third-party" charge sections on your bill. Know how to combat spam texts. In the US, forward the texts to 7726 (SPAM on most keypads). This will alert your cellphone carrier to block future texts from those numbers. Ask your phone carrier about blocking third-party charges. Mobile phone carriers permit outside businesses to place charges on your phone bill, but many carriers also allow you to block these charges for free.

Be Safe Out There.

**Wonders of Coronado and Palo Duro Canyon**

With the rain the Panhandle has received the ranch land is lush and green, and Ole Jim and I were lucky to spend the weekend on the Palo Duro Canyon at our daughter's house.

Riding across the flat plain with an occasional house and barns in the distance stirs my active imagination, and I wonder what Coronado thought and felt with his first sight in 1541.

First, you must travel the Llano Estacado or Staked Plains which was described as "Like the ocean or sea of grass with no tree, stick or rock to guide you." The Coronado Expedition was hunting the City of Gold, and I wonder if they may have felt they won the prize after traveling so far and finally reaching water.

How was Palo Duro Canyon formed? Millions of years ago the

river we know as the Prairie Dog Town Fork of the Red River found a path across the Llano Estacado and began forming the canyon along what is known now as the Caprock Escarpment, the transition between level plains and surrounding rolling terrain. Palo Duro translates from the Spanish meaning "Hardwood" and if you have tried to chop cedar or mesquite you agree they are hard wood.

When Coronado saw the canyon it was inhabited by Apache Indians, but later it was taken over by the Comanche and Kiowa tribes.



**'wick picks**  
by peggy cockerham  
Howardwick • 874-2886

The area was first surveyed in 1852 by Captain Randolph B. Marcy for the US Army who described the Llano Estacado as "the land where no man either savage or civilized permanently abides... a treeless, desolate waste of uninhabitable solitude, which always has been and must continue uninhabited forever."

Wow, I see beauty in that sea of grass then suddenly, the second largest canyon in the United States. It is about 60 miles long and 820 feet deep and beautiful. Col. Randal S. Mackenzie led the last raid on the Comanche tribe in 1874 which made it safe for Charles Goodnight to bring the first herd of cattle to the canyon in 1876 and starting the first cattle ranch, the JA.

If you are a lover of history like me, we live in the right place, the beautiful Texas Panhandle.

**Morrow family reunion was held Saturday**

There were 68 friends and relatives attending this year's Family Reunion. The reunion is held on the first Saturday of August.

This picture was taken after I.B. and Jewel Morrow moved their nine children from Goodnight to Clarendon in 1946.

Top Row: Left to Right: Helen, Kenneth, Ina, Lucy. Bottom Row: Right to Left: Earl, Rosie, Mary, John, Maggie.

Those attending this year's Morrow's Family Reunion: Friends were Darrel and Wilma Leffew. Relatives were Helen Myers' son Larry Myers and Edwina from Pampa. Her granddaughter Tammie Davis of Austin. Helen's great-granddaughter Anastasia and Kaiden Tucker of Caldwell, Tex.

Kenneth's son Danny Morrow and Terri of Plano, Tex. Kenneth's son John Earl Morrow of Clarendon.



Granddaughter Katie and Tim Poland of Amarillo. Granddaughter Evie Morrow and Dylan Wright of Clarendon.

Lucy Torres of Memphis and daughter Sue Ann Espinosa of Memphis. Lucy's son Robert Taylor and

Starlit and Gabe Curry of Canyon. Grandson Robert Taylor, Zeth, Penelope of Amarillo. Lucy's son Mark Taylor and Wanda of Memphis.

Earl's son Michael Morrow and Michele of Clarendon. Earl's grandson Earl Burkhalter and Kaoru of Oklahoma City.

Mary Brown of Amarillo. Mary's son Gary Brown and Pat of Amarillo. Mary's daughter Gayle and Kevin Roberson of Amarillo.

John Morrow and Mary of Clarendon.

Maggie's son Jonathon Stewart and Crystal. Grandson Quinton Stewart of Amarillo. Maggie's daughter Cassie and Michael Lewis of Amarillo. A special thanks to the Donley County Seniors for the use of their building and to the families that brought food.

**Be in the Know!**  
Subscribe Today to the Enterprise!

The Clarendon Church of Christ invites you to watch  
**"In Search of the Lord's Way"**  
every Sunday morning at 7:30 on KAMR Channel 4.

**Morrow Drilling & Service**  
Hwy. 287 West, Clarendon  
Water Well Specialist • Turnkey Systems  
Solar Windmill • Electric Irrigation  
30 Years Experience  
John E. Morrow (806)874-2704 • (806)662-3943

**ACE PEST CONTROL**  
"Is your place an ace place?"  
Terry & Jason Wheeler, C.A. TPCL 10615  
www.acepestcontrol.pro  
**806-372-5449**  
ace.pest@yahoo.com  
We Specialize in General Pest, Termites, Pretreatments  
TERMITE SEASON FAST APPROACHING. CALL US FOR INSPECTIONS.

**PHELPS PLUMBING**  
heating • air-conditioning  
**806-874-1675**  
HVAC# TAACL3255E PLUMBING # 12746

★ **Community Kidz** ★  
★ **Bible Blast** ★  
Wed., August 20<sup>th</sup>  
1:00 - 6:30 p.m.  
Grades 1-5  
**Community Fellowship Church**  
★ (registration required by Aug., 10) ★  
For more information call (806) 874-0963

Fill out and return to Community Fellowship Church before Aug. 10, 2014

Contact information: Children's Ministry of Community Fellowship Church

**CHILD'S NAME:** \_\_\_\_\_

**DATE OF BIRTH:** \_\_\_\_\_

**PARENT/GUARDIAN'S NAME:** \_\_\_\_\_

**CONTACT PH.:** \_\_\_\_\_

**MAILING ADDRESS:** \_\_\_\_\_

**E-MAIL:** \_\_\_\_\_

**T-SHIRT SIZE: YS\_YM\_YL\_AS** \_\_\_\_\_

**FOOD ALLERGIES** \_\_\_\_\_

Name, relation, and contact Phone # of someone who can care for child in your absence: \_\_\_\_\_

I authorize the following individual(s) to bring/pick up my child: \_\_\_\_\_

In case of medical emergency, I \_\_\_\_\_, authorize a trained medical professional to give aid to my child. I have read, understand, and accept the guidelines for participation in Community Fellowship Children's Ministry activities.  
Parent/Guardian Signature \_\_\_\_\_ Date: \_\_\_\_\_

**Subscribe Today!**

**Thank you**

Maxine and I want to express our sincere thanks and deep appreciation to the persons having anything to do with the placement of the 10 Commannments on the courthouse lawn. It is a beautiful stone and a fitting tribute to our Creators and the mind set of our founding fathers.

Thanks again,  
Don & Maxine Robinson

**Last Martin/Ashtola Reunion to be held**

The annual Martin/Ashtola reunion will be this Saturday, August 9. We will meet at the Senior Citizens building in Clarendon. Registration will begin at 10:30 a.m. and lunch will be served at 12:00.

There have been only 6 to 10 people coming for this reunion the last three or four years. We are considering disbanding this group, cancelling any future reunions and donating our money to some Donley County organizations. If you have any thoughts about canceling or keeping this reunion going, show up this Saturday or call Charlene Brown at 806-983-2618 or Mike Graham at 806-874-2806.

We hope to see you Saturday, August 9.  
Charlene Brown

**Free Big E Classified**  
with every new or renewed subscription!

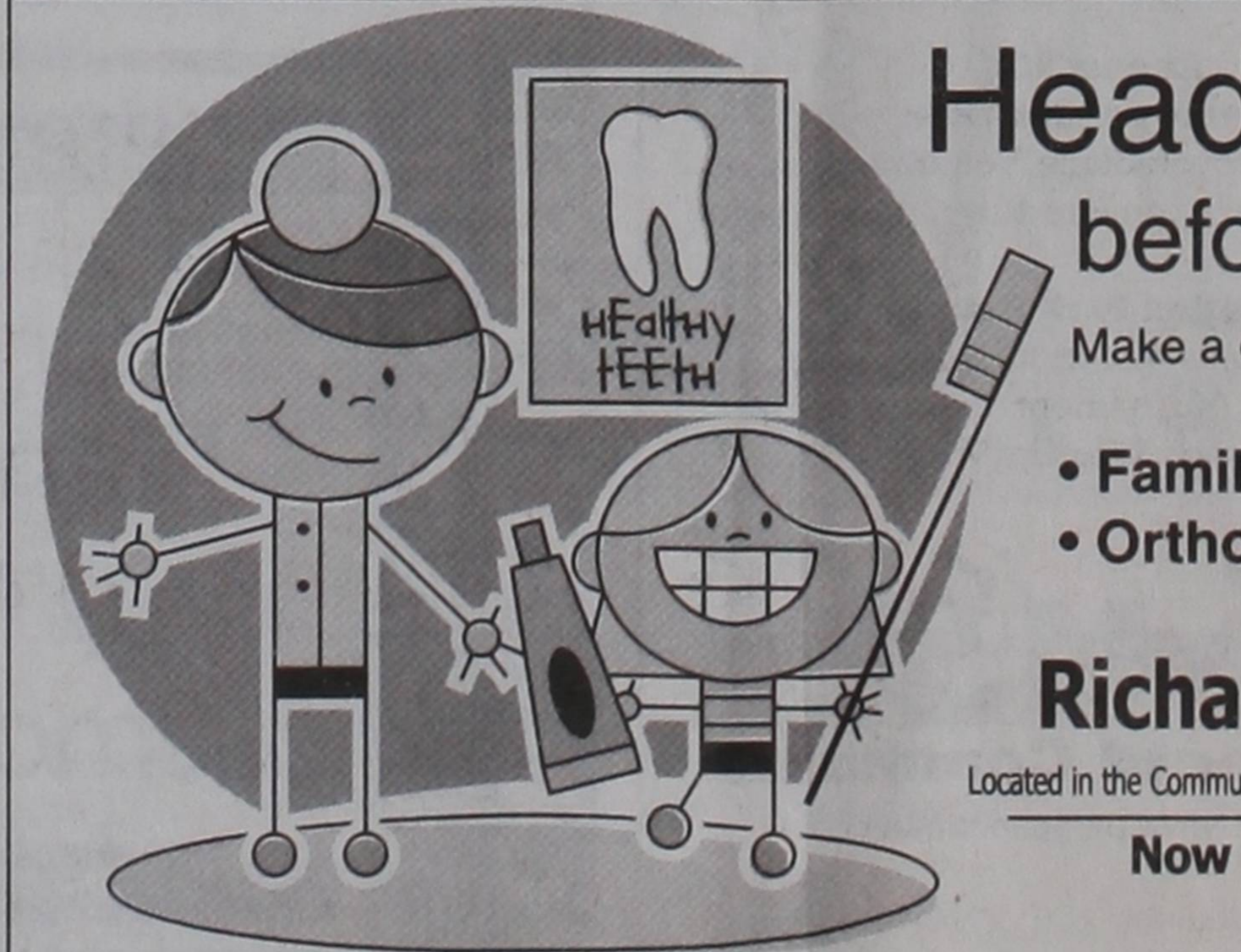

**Head back to the dentist before you head back to school!**

Make a dental check up part of your child's back-to-school routine!

- Family Dentistry
- Orthodontics
- Implants
- Bleaching

**Richard Sheppard, DDS**

Located in the Community Services Building, Medical Center Campus in Clarendon

Now listed in the White Pages!  
806-874-5628



## 'Report cards' for Appraisal Districts

Students get report cards. Employees receive performance evaluations. Businesses are rated by+ consumers and the Better Business Bureau. But have you ever wondered who was in charge of oversight of the appraisal district?

Appraisal districts in Texas have a chief appraiser, who is the chief administrator responsible for daily operations. The chief appraiser reports to a Board of Directors charged with the governance of the appraisal district, including budget, finance and policy matters.

Appraisal Districts must comply with the requirements of the Appraisal Foundation's Uniform Standards of Professional Appraisal Practices (USPAP), which govern all aspects of property appraisal. They must also meet the legal requirements defined in the Texas State Property Tax Code. Texas law requires appraisal districts to appraise all taxable property at 100 percent of its market value.

Market value is defined as the price a property would bring if offered on the open market for a reasonable time with both the buyer and the seller aware of all of the attributes of the property and neither party being under duress to buy or

sell. The Property Tax Assistance Division of the Texas State Comptroller is the agency charged with auditing appraisal districts' appraisal values and district operations.

These audits include a Property Value Study (PVS) and a Methods and Procedure (MAP) review, performed in alternating years. Both are comprehensive with severe consequences if the appraisal district is not in compliance.

In this year's MAP review, the Comptroller's office will ask questions and require documentation regarding Governance, Taxpayer assistance, Operating procedures and Appraisal standards, procedures and methodology. Each information request is designed to assure all appraisal district customers that the appraisal district is performing the required tasks by following the laws and guidelines listed above.

For the 2015 Property Value Study, the state auditor will gather recent sales information, randomly select sales and then compare the sales prices with our appraised values. If our appraised values are higher than the collected sales prices, the auditor will calculate the percentage those appraisals differ from the

market sales. If our appraised values are less than the sales prices, the auditor will calculate the percentage those appraisals are under-appraised. The PVS results can impact the state funding provided to our local school district.

A school district receives its full share of state funding when the PVS determines a school district is maximizing their local effort to generate revenue because the appraisal district is appraising all types of property within an acceptable range of market value.

Appraisal districts have been diligent in the process of gathering sales data and adjusting our values to reflect market value and district employees are confident appraised values are well within the acceptable range.

Appraisal District customers include local taxing entities, taxpayers, and citizens.

"We want to ensure we are prepared to implement any new laws or guidelines," Donley County Appraisal District Chief Appraiser Paula Lowrie said, "but we also strive to be an example of transparency in government and excellence in public awareness and customer service."

## County conservation partners host LWG meeting

The USDA Natural Resources Conservation Service (NRCS) in Texas' Donley County and the Donley County Soil and Water Conservation District cordially invite the public to attend their 2014 Local Working Group (LWG) meeting August 12, 2014, from 4 p.m. to 6 p.m.

The purpose of this annual LWG meeting is to set local conservation priorities and bring conserva-

tion stakeholders together to discuss conservation topics and issues relevant to helping Donley County farmers and ranchers better conserve on-farm natural resources.

The agenda of the meeting is to update attendees on recent conservation efforts and to collect public input to help guide future conservation activities. Through regular identification of conservation opportunities, effective Farm Bill investment can

continue to benefit Donley County. Farmers, ranchers, conservationists, and others interested in obtaining Federal technical and financial assistance to improve private land in Donley County are invited to participate. For more information, please contact Weldon E. Sears, district conservationist, at (806) 874-3561 Ext-3. For more information, visit the NRCS Web site at <http://www.tx.nrcs.usda.gov/>.

## Armstrong County to hold first Cookoff

The first annual Armstrong County Back Roads Bash/ Cook-Off will take place on August 29 and 30 in Claude Texas at the Bert Wooldridge Arena.

Organizers of the event hope \$40,000 dollars to build a barn to house animals for the Armstrong County youth stockshow projects.

For information about entering the IBCA sanctioned cookoff or for vendor space, please feel free to

contact us at [armstrongcountylive-stock@gmail.com](mailto:armstrongcountylive-stock@gmail.com) or Jesus Hernandez (806) 226-2717.

Entry fee is \$15 and 12 and under get in free. Gates will open to the public from 1:00 p.m. until midnight on August 30, 2014.

Performers for the event include Casey Berry and the Live Texas Mosquitoes, Tommy Gallagher Band, Chancy Bernson, and Boys of Claude.

## Back to school drive

The Clarendon Church of the Nazarene will be holding a back to school clothing drive August 8, from 1:00 p.m. - 6:00 p.m.

The goal is to make sure all children in our community and county have clothes and all the supplies they need for school. They have had many donations and will still accept more until Thursday, August 7. They have clothes for everyone from babies to adult.

Please contact Julia Hatfield at 806-205-3120 for more information or if you would like to make a donation.

Looking for pictures featured in the Enterprise?

Visit our online gallery at [www.ClarendonLive.com!](http://www.ClarendonLive.com!)

## Drugs in the News

### Popular Pain Relievers Evaluated for Heart Risk

In a recent study conducted by the ongoing Women's Health Initiative, the risk associated with cardiovascular (CV) events caused by two widely used nonsteroidal anti-inflammatory drugs (NSAIDs) was investigated. It has been widely believed that naproxen is preferred over ibuprofen due to a better CV risk profile for naproxen.

However, the conducted study actually found that naproxen poses a greater CV risk compared to ibuprofen. Ibuprofen, in fact, in this study, was not associated with any increase in CV death, nonfatal heart attack (called a myocardial infarction), or nonfatal stroke. NSAIDs, such as naproxen and ibuprofen, work by blocking a pathway in the body that causes inflammation and pain. Depending on which enzyme in the body the NSAID blocks to a greater degree determines the CV risk assigned to the drug. NSAIDs that selectively block the "COX-1 enzyme" have a lower CV risk associated with them. Ibuprofen, which shows greater selectivity for inhibiting COX-1, compared with naproxen, has a safer CV risk profile, as a result.

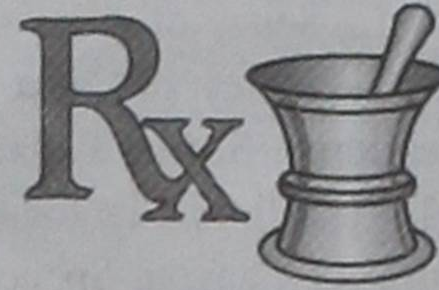

**Mike's PHARMACY**

Call 874-3554 or Toll Free 800-766-2089  
Hwy 287 West • Clarendon, Texas

## LET THE ADVENTURE BEGIN!

Check out [WonderlandPark.com](http://WonderlandPark.com) for more details



Buy ♦ Sell ♦ Trade ♦ Give Away

Joe's Flea Market  
Mon. ♦ Wed. ♦ Fri.  
at 9 a.m.

**KLSR**  
**105.3 FM**

Delivering incomparable in-home care for over 25 years

**Professional Case Management**  
Helping Nuclear Workers Live at Home

806.553.7415  
[procasemanagement.com](http://procasemanagement.com)

## BECAUSE WE SPECIALIZE IN THE NEEDS OF PANTEX WORKERS LIKE YOU

Professional Case Management has been providing in-home care for over 25 years and has been specializing in the nursing needs of former nuclear workers since the EEOICPA program began in 2001. Our local nurses assist with daily activities or extensive, continued care.

Take Advantage of the EEOICPA Benefits You've Earned:

- Largest & most experienced enrolled EEOICPA provider
- Monthly monitoring visits, daily visits, or 24/7
- In-depth knowledge of EEOICPA program

Contact us Today to See if You Qualify.

**Professional Case Management**

Helping Nuclear Workers Live at Home

806.553.7415  
[procasemanagement.com](http://procasemanagement.com)



- CLARENDON**
- AGAPÉ CHRISTIAN CHURCH**  
712 E. 2ND HWY. 287 • MINISTER: ANTHONY KNOWLES  
SUN. SCHOOL: 9:30 A.M. • SUN. SERVICE: 10:30 A.M.
- CALVARY BAPTIST CHURCH**  
US 287 E • 874-3156 • REV. ROBB SEALE  
SUN. SCHOOL: 10 A.M. • SUN. SERVICE: 11 A.M.  
SUN. EVENING: 7 P.M. • WED.: 7 P.M.
- CHURCH OF CHRIST**  
300 S. CARHART • 874-2495 • MINISTER: CHRIS MOORE  
SUN. BIBLE CLASS 9:30 A.M. • SUN. SERVICE: 10:30 A.M.  
SUN. 6 P.M. • WED.: 7 P.M.
- CHURCH OF NAZARENE**  
209 S. HAWLEY • 874-2321 • PASTOR: BILL HODGES  
SUN. SCHOOL: 9:30 A.M. • SUN. SERVICE: 10:30 A.M.  
SUN. EVENING: 6 P.M. • WED.: 7 P.M.
- COMMUNITY FELLOWSHIP CHURCH**  
12148 FM 2162 • 874-0963  
PASTOR: LARRY CAPRANICA  
SUN. SCHOOL: 10 A.M. • SUN. SERVICE: 11 A.M.  
SUN. EVENING: 6 P.M. • WED. COMMUNITY KIDZ 5:30 P.M.  
WED. ADULT BIBLE STUDY: 6 P.M.
- FIRST CHRISTIAN CHURCH**  
120 E. THIRD ST. • PASTOR: DARRELL BURTON  
SUNDAY SERVICE: 9 P.M.
- FIRST ASSEMBLY OF GOD**  
4TH ST. & HWY. 70 SOUTH • PASTOR: MATTHEW STIDHAM  
SUN. SCHOOL: 9:45 A.M. • SUN. SERVICE: 10:40 A.M.  
SUN. EVENING: 6 P.M. • WED. YOUTH: 6:15 P.M.  
WED. BIBLE STUDY: 7 P.M.
- FIRST BAPTIST CHURCH**  
300 BUGBEE AVE. • 874-3833 • REV. LANCE WOOD  
SUN. SCHOOL: 9:45 A.M. • SUN. SERVICE: 10:55 A.M.  
SUN. EVENING: 6 P.M. • KID'S ACTIVITIES: WED. 6 P.M.  
YOUTH STUDY: WED. 7 P.M.  
COLLEGE MINISTRY: WED. 9 P.M.
- FIRST PRESBYTERIAN CHURCH**  
FOURTH & PARKS • PASTOR: REV. ROBBI GANTZ  
FELLOWSHIP: 10:30 A.M.  
SUN. SERVICE: 11 A.M.
- FIRST UNITED METHODIST CHURCH**  
420 S. JEFFERSON • 874-3667 • PASTOR: LLOYD STICE  
SUN. SERVICE: 9:45 A.M. • SUN. SCHOOL: 11 A.M.
- JESUS NAME APOSTOLIC CHURCH**  
720 E. MONTGOMERY • 205-1149 • REV. 874-2078  
REV. CALVIN BURROW  
SUN. SERVICES: 3 P.M. • WED.: 7 P.M.
- BODY OF CHRIST MINISTRIES:**  
501 S. MCCLELLAND • PASTOR: R.W. ELLERBROOK  
SATURDAY: 6 P.M. • SUNDAY DISCIPLESHIP CLASS: 9:30 A.M.  
SUN.: 10:30 A.M. • SUN. LIFE GROUP: 4:30 P.M.  
WED.: 6:30 P.M.
- CHRIST'S KIDS OUTREACH MINISTRY:**  
416 S. KEARNEY • JANET & STEVE CARTER • 874-2007  
SUN. BREAKFAST 9:30 A.M. • SUN. PRAISE & WORSHIP 10 A.M.  
SUNDAY SCHOOL: 10:30 A.M. • WED.: 5 P.M.

- ST. JOHN THE BAPTIST EPISCOPAL CHURCH**  
301 S. PARKS ST. • 874-2511 • REV. JIM AVENI  
FIRST SUNDAY SERVICE: 11 A.M.
- ST. MARY'S CATHOLIC CHURCH**  
MONTGOMERY & MCCLELLAND  
FR. AROKIA RAJ SAMALA  
SUN. MASS 11 A.M.
- ST. STEPHENS BAPTIST CHURCH**  
300 N. JEFFERSON ST. • PASTOR: ROY WILLIAMS  
SUN. SCHOOL: 10 A.M. • SUN. SERVICE: 11:15 A.M.  
WED.: 7 P.M. (WEATHER PERMITTING)
- TRUE CHURCH OF GOD & CHRIST**  
301 N. JEFFERSON • ST. PASTOR: JEFF RILES  
SUN. SCHOOL: 10 A.M. • SUN. SERVICE: 11:15 A.M.  
WED.: 7 P.M.
- ARENA OF LIFE COWBOY CHURCH**  
214 S. KEARNEY • PASTORS: BUNK & AMY SKELTON  
SUN. SCHOOL: 10:30 A.M. • TUE. BIBLE STUDY: 7 P.M.

- HEDLEY**
- CHURCH OF CHRIST**  
110 E. SECOND ST. • MINISTER: BRIGHT NEWHOUSE  
SUN. BIBLE CLASS: 10 A.M. • SUN. SERVICE: 11 A.M.  
SUN. EVENING: 6 P.M. • WED.: 7:30 P.M.
- FIRST UNITED METHODIST CHURCH**  
200 N. MAIN ST. • PASTOR: STAN COSBY  
SUN. SERVICE: 4:00 P.M.
- FIRST BAPTIST CHURCH**  
210 N. MAIN ST. • 856-5980 • PASTOR: BRUCE HOWARD  
SUN. SCHOOL: 10 A.M. • SUN.: 11 A.M. & 6 P.M.  
WED.: 7 P.M.

- HOWARDWICK**
- FIRST BAPTIST CHURCH**  
235 RICK HUSBAND BLVD. • 874-3326 • REV. DAVE STOUT  
SUN. SCHOOL: 10 A.M. • SUN. SERVICE: 10:45 A.M.  
SUN. EVENING: 6 P.M. • WED.: 6 P.M.

- OLD PATHS PRIMITIVE BAPTIST CHURCH**  
HEREFORD LANE AT HWY 70 • 673-1770  
3RD SUNDAYS - DON MARTIN • 4TH SUNDAYS - DON WATSON  
SERVICES: 10:30 A.M.

- MARTIN**
- MARTIN BAPTIST CHURCH**  
US 287 W  
SUN. SCHOOL: 10 A.M. • SUN. SERVICE: 11 A.M.  
SUN. EVENING: 6 P.M. • WED.: 7 P.M.

- BRICE**
- BRICE DELIVERANCE TABERNACLE**  
PASTOR: LOUIS BENNETT  
SUNDAY: 9:45 A.M. • SUN. EVENING: 6 P.M.  
WED.: 6 P.M.

- SPONSORED BY**
- ROBERTSON FUNERAL DIRECTORS**
- COUNTRY BLOOMERS FLOWERS & GIFTS**
- WALLACE MONUMENT CO.**
- MCKINNEY MOTOR CO.**
- 3-H ALL NATURAL BEEF**
- CLARENDON FAMILY MEDICAL CENTER**
- ROLLING PLAINS AG COMPOST**
- J&W LUMBER**
- PILGRIM BANK**
- For corrections or additions, call the Enterprise at:
- 874-2259**



**Stitched with love**

Jalen Butler presents Teresa Dronzek with her prize won in the Quilt Raffle held in support of the Summer Lunch Program.

COURTESY PHOTO

**Obituaries**

**Seitz**

Willie Jo Seitz, 91, died July 27, 2014, in Canyon. Private family services were held. Arrangements were under the direction of Brooks Funeral Directors



Seitz

to John Gossett and Euna Denton. She graduated from Eldorado High School and attended Altus Community College. She married Elbert L. Seitz in Lovington, New Mexico on February 5, 1949. They have been married 65 years.

Willie Jo worked for the Texas Department of Health and Human Services for 22 years. She was a loving companion and will be fondly remembered as 'Grandma' by her grandchildren and great-grandchildren. She loved ice cream, cookies, and puppies. Willie Jo took pride in her grandchildren and did everything she could to ensure that they received a college education. She

will be greatly missed.

She preceded in death by her mother, a brother, Garland Gossett; and a sister, Bobby Miller.

She is survived by her husband, Elbert L. Seitz, of Canyon; daughter, Jo Jan Nunley, of Canyon; three grandchildren, Scarlet Estlack and husband, Russell, of Clarendon, Patrick Nunley, of Canyon, Spencer Nunley and wife, Cathy, of Canyon; three great-grandchildren, Maggie Nunley, of Canyon, Nathan and Daniel Estlack, of Clarendon; and a special cousin, Tommy Kirk, of New York.

Please sign the online guest registry at [www.brooksfuneral.com](http://www.brooksfuneral.com)

Willie Jo Seitz was born February 14, 1923, in Eldorado, Oklahoma

**POSITIVE FEED SALES**  
All-In-One 30% Supplement for Cattle  
*Brangus Heifers For Sale*  
DANNY ASKEW  
874-5001 or 874-3844

**Kenny's Barber Shop and Clarendon Auto Sales**  
3rd & Jefferson, Clarendon  
**874-9308**  
We appreciate your business!

**VEW BREAKFAST CHALLENGE**  
Eat our meal in 30 minutes or donate \$20<sup>00</sup>  
**OPEN**  
Monday - Friday 6 a.m. - 10 a.m.  
Sat. 6:30 a.m. - 10:30 a.m.

Subscribe Today. Call 874-2259.

**GLASSTECH WINDSHIELD REPAIR**  
Larry & Donna Hicks  
Call Donna at 806-874-3108 • 806-205-1501  
**SEAL THAT CHIP BEFORE IT SPLITS!**

Nita Massey, LNFA Administrator  
**Memphis Convalescent Center**  
(806) 259-3566 Phone  
(806) 259-5098 Fax  
(806) 205-2442 Cell  
Nita\_Massey@csnhc.com  
1415 N. 18th Street  
Memphis, Texas 79245  
[www.memphisconvalescent.com](http://www.memphisconvalescent.com)

*Claude Family Medical Clinic*  
JANET BILYEU, RN, FNP-C  
RANDY STEWART, M.D.  
201 PARKS STREET, CLAUDE, TX 79019  
TELEPHONE: (806) 226-5611 • FAX: (806) 226-6703  
CMEDICAL@AMAONLINE.COM  
HOURS: MON. - THURS. 8:30 - 4:30  
FRI. 8:30 - 12:00 P.M.  
APPOINTMENTS ENCOURAGED  
Accepting New Patients • Medicare & Most Insurances Accepted  
"Let Us Take Care Of All Your Family's Health Care Needs"

**2014 Property Tax Rates in Donley County**

This notice concerns 2014 property tax rates for Donley County. It presents information about three tax rates. Last year's tax rate is the actual rate the taxing unit used to determine property taxes last year. This year's effective tax rate would impose the same total taxes as last year if you compare properties taxed in both years. This year's rollback tax rate is the highest tax rate the taxing unit can set before taxpayers can start tax rollback procedures. In each case these rates are found by dividing the total amount of taxes by the tax base (the total value of taxable property) with adjustments as required by state law. The rates are given per \$100 of property value.

	General Fund	County Special
<b>Last year's tax rate:</b>		
Last year's operating taxes	927,945.65	214,186.59
Last year's debt taxes	155,432.95	0.00
Last year's total taxes	1,083,378.60	214,186.59
Last year's tax base	205,661,713	203,020,460
Last year's total tax rate	0.526777 /\$100	0.105500 /\$100
<b>This year's effective tax rate:</b>		
Last year's adjusted taxes (after subtracting taxes on lost property)	974,985.75	192,854.05
+ This year's adjusted tax base (after subtracting value of new property)	201,200,224	198,544,157
= This year's effective tax rate for each fund	0.484584 /\$100	0.097134 /\$100
Total effective tax rate	0.581718 /\$100	0.097134 /\$100
<i>(Maximum rate unless unit publishes notices and holds hearings.)</i>		
<b>This year's rollback tax rate:</b>		
Last year's adjusted operating taxes (after subtracting taxes on lost property and adjusting for any transferred function, tax increment financing, state criminal justice mandate, and/or enhanced indigent health care expenditures)	840,772	198,525
+ This year's adjusted tax base	201,200,224	198,544,157
= This year's effective rate	0.417878 /\$100	0.099990 /\$100
x 1.08 = this year's maximum operating rate	0.451308 /\$100	0.107989 /\$100
+ This year's debt rate	0.068446 /\$100	0 /\$100
= This year's rollback rate for each fund	0.519754 /\$100	0.107989 /\$100
This year's total rollback rate	0.627743 /\$100	0.107989 /\$100

**Statement of Increase/Decrease**  
If Donley County adopts a 2014 tax rate equal to the effective tax rate of \$ 0.581718 per \$100 of value, taxes would increase compared to 2013 taxes by \$ 7,517.00.

**Schedule A — Unencumbered Fund Balances**  
The following estimated balances will be left in the unit's property tax accounts at the end of the fiscal year. These balances are not encumbered by a corresponding debt obligation.

Type of Property Tax Fund:	M & O	I & S
Balance:	\$ 0.00	\$ 0.00

**Schedule B — 2014 Debt Service**  
The unit plans to pay the following amounts for long-term debts that are secured by property taxes. These amounts will be paid from property tax revenues (or additional sales tax revenues, if applicable).

Description of Debt	Principal or Contract Payment to be Paid from Property Taxes	Interest to be Paid from Property Taxes	Other Amounts to be Paid	Total Payment
Debt	\$ 135,769.52	\$ 0.00	\$ 0.00	\$ 135,769.52
	\$ 0.00	\$ 0.00	\$ 0.00	\$ 0.00
	\$ 0.00	\$ 0.00	\$ 0.00	\$ 0.00
	\$ 0.00	\$ 0.00	\$ 0.00	\$ 0.00
<i>(expand as needed)</i>				
Total required for 2014 debt service			\$	135,769.52
- Amount (if any) paid from funds listed in Schedule A			\$	0.00
- Amount (if any) paid from other resources			\$	0.00
- Excess collections last year			\$	0.00
= Total to be paid from taxes in 2014			\$	135,769.52
+ Amount added in anticipation that the unit will collect only 98 % of its taxes in 2014			\$	2,771.00
= Total Debt Levy			\$	138,540.52

**Schedule D — State Criminal Justice Mandate (For Counties)**  
The Donley County Auditor certifies that Donley County has spent \$82,840.00 in the previous 12 months beginning Oct. 1, 2013, for the maintenance and operations cost of keeping inmates sentenced to the Texas Department of Criminal Justice. County Sheriff has provided information on these costs, minus the state revenues received for reimbursement of such costs.

This notice contains a summary of actual effective and rollback tax rates' calculations. You can inspect a copy of the full calculations at 304 S Kearney St Clarendon TX

Name of person preparing this notice Paula Lowrie  
Title Chief Appraiser  
Date prepared 8/1/2014

**2014 Property Tax Rates in City of Clarendon**

This notice concerns 2014 property tax rates for City of Clarendon. It presents information about three tax rates. Last year's tax rate is the actual rate the taxing unit used to determine property taxes last year. This year's effective tax rate would impose the same total taxes as last year if you compare properties taxed in both years. This year's rollback tax rate is the highest tax rate the taxing unit can set before taxpayers can start tax rollback procedures. In each case these rates are found by dividing the total amount of taxes by the tax base (the total value of taxable property) with adjustments as required by state law. The rates are given per \$100 of property value.

	General Fund
<b>Last year's tax rate:</b>	
Last year's operating taxes	221,040.50
Last year's debt taxes	147,360.33
Last year's total taxes	368,400.83
Last year's tax base	56,677,051
Last year's total tax rate	0.650000 /\$100
<b>This year's effective tax rate:</b>	
Last year's adjusted taxes (after subtracting taxes on lost property)	305,545.89
+ This year's adjusted tax base (after subtracting value of new property)	49,207,231
= This year's effective tax rate	0.620936 /\$100
<i>(Maximum rate unless unit publishes notices and holds hearings.)</i>	
<b>This year's rollback tax rate:</b>	
Last year's adjusted operating taxes (after subtracting taxes on lost property and adjusting for any transferred function, tax increment financing, state criminal justice mandate, and/or enhanced indigent health care expenditures)	265,458
+ This year's adjusted tax base	49,207,231
= This year's effective rate	0.539469 /\$100
x 1.08 = this year's maximum operating rate	0.582626 /\$100
+ This year's debt rate	0.291674 /\$100
= This year's total rollback rate	0.8743 /\$100

A county that collects the additional sales tax to reduce property taxes, including one that collects the tax for the first time this year, must insert the following lines:

- Sales tax adjustment rate	0.165385 /\$100
= Rollback tax rate	0.708915 /\$100

**Statement of Increase/Decrease**  
If City of Clarendon adopts a 2014 tax rate equal to the effective tax rate of \$ 0.620936 per \$100 of value, taxes would increase compared to 2013 taxes by \$ 3,358.00.

**Schedule A — Unencumbered Fund Balances**  
The following estimated balances will be left in the unit's property tax accounts at the end of the fiscal year. These balances are not encumbered by a corresponding debt obligation.

Type of Property Tax Fund:	M & O	I & S
Balance:	\$ 0.00	\$ 0.00

**Schedule B — 2014 Debt Service**  
The unit plans to pay the following amounts for long-term debts that are secured by property taxes. These amounts will be paid from property tax revenues (or additional sales tax revenues, if applicable).

Description of Debt	Principal or Contract Payment to be Paid from Property Taxes	Interest to be Paid from Property Taxes	Other Amounts to be Paid	Total Payment
Tax Notes	\$ 60,000.00	\$ 9,558.00	\$ 0.00	\$ 69,558.00
Bonds	\$ 65,000.00	\$ 10,287.00	\$ 0.00	\$ 75,287.00
<b>Total required for 2014 debt service</b>				
- Amount (if any) paid from funds listed in Schedule A			\$	0.00
- Amount (if any) paid from other resources			\$	0.00
- Excess collections last year			\$	0.00
= Total to be paid from taxes in 2014			\$	144,845.00
+ Amount added in anticipation that the unit will collect only 100 % of its taxes in 2014			\$	0.00
= Total Debt Levy			\$	144,845.00

**Schedule C — Expected Revenue from Additional Sales Tax**  
(For hospital districts, cities and counties with additional sales tax to reduce property taxes)  
In calculating its effective and rollback tax rates, the unit estimated that it will receive \$ 82,130.00 in additional sales and use tax revenues. For County: The county has excluded any amount that is or will be distributed for economic development grants from this amount of expected sales tax revenue.

This notice contains a summary of actual effective and rollback tax rates' calculations. You can inspect a copy of the full calculations at 304 S Kearney Clarendon TX

Name of person preparing this notice Paula Lowrie  
Title Chief Appraiser  
Date prepared 8/1/2014

# big E classifieds

Call in your ad at  
**874-2259**

Deadline: Monday @ 5 p.m.  
Prepayment required.  
Visa / MasterCard accepted.



**MEETINGS**

**Clarendon Lodge #700 AF&AM**  
Stated meeting: Second Mondays, 7:30 p.m. Refreshments at 6:30 p.m. Practice: Fourth Mondays, 7 p.m. Jim Owens - W.M., Greff Betts - Secretary, 2 B I, ASK I

**Donley County Memorial Post**  
7782 Veterans of Foreign Wars. Meets first Tuesday at 7 p.m. 822-VETS.

**Clarendon Lions Club** Regular meeting each Tuesday at noon. Ashlee Estlack, Boss Lion, Roger Estlack, Secretary

**Clarendon Chamber of Commerce** Regular meeting 2nd Thursday each month at 5:30 p.m. at Burton Memorial Library.

**Big E Meeting Listings** only \$8.50 per month. Call 874-2259 to have your club or organization meeting listed.

**LEGAL NOTICE**

**NOTICE OF PUBLIC BUDGET HEARING CLARENDON COLLEGE**  
The Clarendon College Board of Regents will hold a public hearing on the College's proposed budget for 2014-2015 fiscal year on Thursday, August 14, 2014, at 11:30 a.m. in the VIP Room of the Bairfield Activity Center, Clarendon College Campus, Clarendon, Texas.

**NOTICE OF TAX RATE CLARENDON COLLEGE**  
The Clarendon College District will hold a meeting at 12:30 PM on August 14, 2014, in the VIP Room at the Bairfield Activity Center, Clarendon College Campus, in Clarendon, Texas, to consider adopting a proposed tax rate for tax year 2014. The proposed tax rate is 0.220802 per \$100 of value. The proposed tax rate would increase total taxes in the Clarendon College District by 8%.

**PUBLIC NOTIFICATION OF NONDISCRIMINATION IN CAREER AND TECHNICAL EDUCATION PROGRAMS**  
Clarendon Consolidated Independent School District offers career and technical education programs in vocational agriculture, business and technical preparation, and family and consumer sciences. Admission to these programs is based on interest and aptitude, age appropriateness, and class space availability. It is the policy of Clarendon CISD not to discriminate on the basis of race, color, national origin, sex or handicap as required by Title VI of the Civil Rights Act of 1964, as amended; Title IX of the Education Amendments of 1972; and Section 504 of the Rehabilitation Act of 1973, as amended. It is the policy of Clarendon CISD not to discriminate on the basis of race, color, national origin, sex, handicap, or age in its employment practices as required by Title VI of the Civil Rights Act of 1964, as amended; Title IX of the Education Amendments of 1972; the Age Discrimination Act of 1975, as amended; and Section 504 of the Rehabilitation Act of 1973, as amended. Clarendon CISD will take steps to assure that lack of English language skills will not be a barrier to admission and participation in all educational and vocational programs. For information about your rights or grievance procedures, contact the Title IX Coordinator, and/or the Section 504 Coordinator, Melinda Shadle, at 822 West 5th Street, 806-874-3232.

**HELP WANTED**

**NURSES UNLIMITED, INC.** Is seeking enthusiastic and outgoing attendants to assist clients in the home with personal care, meal prep and light housekeeping. P-T E.O.E Call 888-859-0631

**HEDLEY FEEDLOT** is hiring an Office Manager Competitive Salary, 401k & Health Insurance Please call 806.856.5441 M-F 8am-12pm to schedule an interview.

**HELP WANTED:** in the Clarendon College Cafeteria for the upcoming semester. Great Western dining service has openings for part time/ evenings/weekend shift for general workers, line servers, and cooks assistant. Experience in cooking and baking is helpful but will train. Looking for dependable and hard working individuals in a fast pace setting. Competitive pay. Please call Gina McKinney for an application at 806-336-3450 by August 18th.

**THE CLARENDON ECONOMIC** Development Corporation is seeking applications for the Director of Tourism & Economic Development. The primary function of this position is to encourage appropriate tourism and business development for the City of Clarendon, direct and manage the Clarendon EDC and Clarendon Visitor Center, and provide supervision and counsel to the Clarendon Chamber of Commerce. Estimated job start time is September 1, 2014. For a complete job description, contact Chandra Eggemeyer at tourism@cityofclarendontx.com

**HELP WANTED**

**BEST WESTERN RED RIVER INN** is taking applications for a Maintenance Assistant. Please apply in person.

**BEST WESTERN RED RIVER INN** is taking applications for a Housekeeping Attendant. Please apply in person.

**FOR RENT**

**FOR RENT:** 2 bedroom. Call 874-0043 for more information.

**FOR RENT:** 1 bedroom house. Call 359-9395 for more information.

**THANK YOU**

**WE WOULD LIKE TO THANK:** Regina Herndon and all of her volunteers, the softball teams, the horseshoe teams, Annette and Benny Osborn for announcing, and all of the ladies that made donuts, brownies, and rice krispies. Also a huge thank you to everyone for the sponsorships and donations. The Donley County Senior Citizen Center

**SERVICES**

**NEED A MINISTER?** Call 205-1015.

**ASKEW'S LAWN MOWING SERVICE** call Dale at 806-679-2738.

**SMALL ACREAGE PLANTING**, fertilizer & compost spreading, disk, and rototilling. Call Jobs at 806-205-0270 for a free estimate. 11-ctc

**ASSISTED LIVING HOME** in Clarendon has available a very large private room (15' x 15') with private bath and large walk-in closet. All meals and care. Warm and safe environment. Twenty-three years worth of excellent references. Transportation to local appointments. Good food, good care, good company. 874-5000. State License #125054

**REAL ESTATE**

**3 BEDROOM, 1 1/5 BATH, CARPORT:** 710 South Allen. Newly remodeled. Call for appointment. 806-570-8869.

**VICTORIAN STYLE TWO** story house in Hedley for sale. Four bedroom 2 bath. Lots of trees on 1.5 acres. 125 SE 6th St. \$21,500. 806-662-1095

**14 X 80 MANATEE MOBILE** home. 1983 model in good condition. 3 bedroom, 1 3/4 bath, central heat, new chain link fence in backyard, storm shelter, pole barn, shop, storage building on 6 lots. Saints Roost Edition of Clarendon. Serious enquiry's only. 20,000.00 806-202-0965

**NICE HOME FOR SALE** in Howardwick. 2000 square feet, 3 bedroom, 2 bath, large den with fireplace, central heat & air, formal dining room, breakfast nook, new paint, new carpet, new tile, 17x22 den with 14 ft ceilings, and 30x30 garage under house. Located on 4 lots, with back garden house with single garage. Call 874-9392 or 336-9131 for more information.

**ANNOUNCEMENTS**

**Saints' Roost Museum**  
610 East Harrington  
Tuesday - Saturday  
10 a.m. to 5 p.m.  
Open for appointments.  
Call 874-2746.

**COMMUNITY CARE CENTER IS NOW HIRING**  
**Experienced D.O.N.'s**  
Pay based on experience.  
Please call June Davis or Cissy Hernandez at 874-5221.

**COMMUNITY CARE CENTER IS NOW HIRING**  
**A Bussiness Office Manager**  
Pay based on experience.  
Please call 874-5221.

**COMMUNITY CARE CENTER IS NOW HIRING**  
**CNA'S & LVN'S**  
Pay based on experience.  
Please call June Davis or Cissy Hernandez at 874-5221.

**FOR SALE**  
**702 S. Gorst • Clarendon**  
Blue house, one acre,  
3 bedroom, 1 1/2 bath.  
Super neat place!  
Reduced to **\$72,500.00**  
Call Cindy at 806-677-4461.

**REAL ESTATE**

**Jim Garland Real Estate**  
806-874-3757  
• Have buyers for ranches, farms, & recreational properties.

**GARAGE SALE**

**HUGE GARAGE SALE** around back under the carport! Too many items to list! 1413 West 5th Saturday, August 9, 8:00 am - noon.

**COMMUNITY CARE CENTER IS NOW HIRING**  
**A Bussiness Office Manager**  
Pay based on experience.  
Please call 874-5221.

**HELP WANTED**

**SONIC YOU KNOW WHAT'S FUN?**  
Getting paid to be part of a team that knows everyone wins when everyone gets to be their own awesome self.  
We like your spirit and we want to see you **WORK IT** here with us!

5591 Store Number    79226 Zip Code  
SONICDRIVEIN.COM / JOBS

**REAL ESTATE**

**Joe T. Lovell Real Estate**  
202 W. 3rd St.  
Call 806-874-9318 to schedule a showing of the following listings.

**REAL ESTATE**

**Whitaker Real Estate**  
Specializing in Farm and Ranch Property  
**Lewis Whitaker, Broker**  
**Lee Whitaker, Broker**

4600 I-40 West, Suite 101 Office (806) 356-6100  
Amarillo, Texas 79106 Fax (806) 356-6517  
www.whitakerrealestate.com

**REAL ESTATE**

**LINDA M. NAYLOR REAL ESTATE**  
Providing a Personal Touch!  
Texas Licensed Real Estate Broker  
License # 604414  
Cell Phone: (806) 204-0005  
403 N. Johnson St., Hedley, Texas 79237  
e-mail: naylor@windstream.net

**Subscribe Today**  
Call 874-2259 for more information

**NOTIFICACION PUBLICA DE NO DISCRIMINACION EN PROGRAMAS VOCACIONALES (Career and Technical Education Programs)**  
Clarendon Consolidated Independent School District ofrece programas vocacionales en la agricultura, los negocios, y la preparación técnica. La admisión a estos programas se basa en el interés, la habilidad, la edad apropiada, y el espacio de clase probabilidades. Es norma de Clarendon CISD no discriminar por motivos de raza, color, origen nacional, sexo o impedimento, en sus programas, servicios o actividades vocacionales, tal como lo requieren el Título VI de la Ley de Derechos Civiles de 1964, según enmienda; el Título IX de las Enmiendas en la Educación, de 1972, y la Sección 504 de la Ley de Rehabilitación de 1973, según enmienda. Es norma de Clarendon CISD no discriminar por motivos de raza, color, origen nacional, sexo, impedimento o edad, en sus procedimientos de empleo, tal como lo requieren el Título VI de la Ley de Derechos Civiles de 1964, según enmienda; el Título IX de las Enmiendas en la Educación, de 1972, la ley de Discriminación por Edad, de 1975, según enmienda, y la Sección 504 de la Ley de Rehabilitación de 1973, según enmienda. Clarendon CISD tomará las medidas necesarias para asegurar que la falta de habilidad en el uso del inglés no sea un obstáculo para la admisión y participación en todos los programas educativos y vocacionales. Para información sobre sus derechos o procedimientos de quejas, comuníquese con el Coordinador del Título IX, y/o el Coordinador de la Sección 504, Linde Shadle, en 822 West 5th Street, 806-874-3232.

**GREENBELT LAKE**

**3 BEDROOM - 4 BATH - WITH NEW ROOF** - large tress & lots of shrubbery - deer, turkey and wild birds enjoy this place and so will you - West side of lake on Lease Lots #27 - for \$145,000. REDUCED TO 137,500.

**CLAUDE RESIDENTIAL**

**2323 SQ FT BRICK** - open den/kitchen - built in appliances - beautiful wood cabinets - built in desk - Murphy bed in den - very large living/ dining room - 2 & 1/2 baths (one private with master bedroom) - large utility room - abundant storage - attached 2-car garage - central h/a - chain link fenced b/yd - efficiency apartment built over large concrete cellar - good location at 307 Western for \$135,000.

**CLAUDE COMMERCIAL**

**CHOICE BUSINESS BUILDING SITE** - Intersection of Hwy 287 and State Hwy 207 North with frontage on both busy highways. Diagonally across Hwy 287 from new Cefco complex - survey available.

**RANCH AND FARMLAND**

**EXCEPTIONAL 2272 ACRE OPERATING AND HUNTING RANCH IN THE MIDDLE OF THE BEST DEER, TURKEY AND QUAIL HUNTING IN THE PANHANDLE** - recently remodeled ranch home - abundant well water plus lake and large pond - good corrals - modern/rustic hunting lodge plus hunter's bunk house with cooking and sleeping facilities - the ideal working and recreational ranch - (DIVIDING INTO THREE TRACTS OF 1280 ACRES - 588 ACRES AND 403 ACRES +/- A POSSIBILITY) check out the pictures on www.joelovellrealestate.com > Farms & Ranches > Collingsworth County - then call for details.

**PUBLISHER'S NOTICE:** All real estate advertising in this newspaper is subject to the Fair Housing Act which makes it illegal to advertise any preference, limitation, or discrimination based on race, color, religion, sex, handicap, familial status, or national origin, or an intention, to make any such preference, limitation, or discrimination. Familial status includes children under the age of 18 living with parents or legal custodians, pregnant women, and people securing custody of children under 18. This newspaper will not knowingly accept any advertising for real estate which is in violation of the law. Our readers are hereby informed that all dwellings advertised in this newspaper are available on an equal opportunity basis. To complain of discrimination, call HUD toll-free at 1-800-669-9777. The toll-free telephone number of the hearing impaired is 1-800-927-9275. CLASSIFIED AD RATES are \$8.00 for the first 15 words and 15¢ for each additional word. Special type-faces or boxes are extra. THANK YOU NOTES are \$10.00 for the first 40 words and 15¢ for each additional word. DEADLINES are 5:00 p.m. each Monday, subject to change for special editions and holidays. PREPAYMENT IS REQUIRED on all ads except for customers with established accounts. Visa and MasterCard accepted. ERRORS: Check your ad on its first printing. Errors not corrected within ten days of the first printing are the responsibility of the advertiser.

**Let the Big E work for you!**

**EXCEPTIONAL 2 BEDROOM - ONE BATH - BRICK IN WEST CLARENDON** - oversized attached garage includes shop with counter top and storage cabinets - like new kitchen cabinets & counter top - in-law generator - d/washer - work island/ breakfast table combo - pantry - living room includes mock fireplace with electric burner - bath with tub/shower - 2 car garage - 2 car port - covered patio - fenced back yard - landscaped - large concrete cellar under garage with inside entrance - close to school & shopping area @ 609 W. 3rd for \$69,000.

**UNDER CONTRACT**

**UNDER CONTRACT**

**UNDER CONTRACT**

**SERVICES**

**Where's Your Card?**  
Let us get you started with professional design and printing solutions for all of your marketing and promotional needs!

1000 Full-Color Business Cards Only \$91 + tax

Business Cards  
Fliers • Brochures  
Envelopes • Stationery  
Postcards • Posters  
Promotional Items

Call Today • 806-874-2259

**THE CLARENDON Enterprise**  
THE CLARENDON NEWS & THE DONLEY COUNTY LEADER

**CLAUDE COMMERCIAL**

**FOR LEASE OR SALE**  
Beautifully restored and totally renovated commercial office building. Brick with 1500 sq. ft. and a 750 sq. ft. basement New wiring, plumbing, wood floors, windows and central heat/air. Two bathrooms and one is a handicap accessible bathroom Several offices and a conference room. Handicap ramp READY TO MOVE IN AND SET UP YOUR BUSINESS.  
Owner will entertain reasonable offers. REDUCTION OF \$10,000.00 FROM \$175,000.00 TO \$165,000.00.

**REAL ESTATE**

**320 ACRES WITH HOME** AND TWO WELLS HIGHWAY 70 SOUTH. Excellent perimeter and cross fences \$1550 PER ACRE. OWNER WILL SPLIT ACREAGE INTO SMALLER TRACTS UPON REQUEST.

**Two Bedroom - 1 bath** trailer on two lots appliances included in sale. Nice carport and cellar. 357 Walleye St., Howardwick, Texas. \$19,500.00.

**COMING SOON:** Newly built duplexes. Call for details

**For Lease or Sale**  
Beautifully restored and totally renovated commercial office building. Brick with 1500 sq. ft. and a 750 sq. ft. basement New wiring, plumbing, wood floors, windows and central heat/air. Two bathrooms and one is a handicap accessible bathroom Several offices and a conference room. Handicap ramp READY TO MOVE IN AND SET UP YOUR BUSINESS.  
Owner will entertain reasonable offers. REDUCTION OF \$10,000.00 FROM \$175,000.00 TO \$165,000.00.

**REAL ESTATE**

**Brick house at 1112 West 8th** in Clarendon. 2 bedroom, 1 bath. Detached garage with studio apartment, carport, fenced backyard. Needs some TLC. Price reduction \$40,000.

**710 S. Goodnight:** 3 Bedroom/2 Bath w/ garage apartment \$59,900.00

**Pictures at lmnaylorrealestate.com**

**REAL ESTATE**

**3603 CO Rd. 29 Giles, Texas** 1888 sq.ft., 3 Bedrooms, 2 Baths, Deck, Two-car, carport, Workshop, Water well, and 1.27 acres. \$49,000.00

**303 Adamson, Hedley, Texas** Brick, 1877 sq.ft., 3 Bedrooms, 2 Baths, Attached garage, Carport, 6 lots, Water well, Two storage buildings, and Large deck. \$90,000.00

**DRASTIC PRICE REDUCTION TO \$130,000.00** Amazing Home and 1 acre of land: 2158 sq. ft., 4 bedrooms, 2 & 1/2 Baths, finished basement, city water, city sewer, water well, mature landscaping 605 S. Orpe on 70 S.

**Leased Lot #123 Howardwick** Mobile Home 2040 sq. ft. 2 Bedroom, 2 Bath, Huge sun room, Two car metal shed, 1 Car carport, Storage building, Kitchen appliances included, Golf Cart included. Price \$50,000.00

**502 E. Wood** Stucco 1456 sq.ft. 3 Bedroom, 1 Bath, Detached garage, Carport. Price \$60,000.00

**930 W. 5th** Brick 1778 sq. ft., 3 Bedrooms, 2 Baths, Finished Basement - 4th Bedroom, Detached garage, Carport, 600 sq.ft. Apartment above garage. Price \$135,000.00

**Home for Sale in Hedley:** Brick home at 420 Railroad St. Sits on 4 Lots. 1900 Sq. Ft., 3/4 Bedrooms, 2 Baths, Two-car garage, Covered patio, Carport, Huge storage building, Fenced backyard, corner Lot. Price: \$74,500.00

**702 E. Wood St:** 1716 Sq.Ft., Corner Lot, 3 Bedrooms, 2 Baths, Basement, Carport. Bargain Price: \$65,000.00.

**Charming Remodeled Two story Home** Corner Lot at 521 4th Street. 2072 Sq.Ft., 3 Bedrooms, 2 Baths. Reasonably Priced at \$69,000.00.

**4000 sq. ft. building** with a commercial overhead door in the back storage area Located on HWY 287 in the business district. \$69,900.00

**Lot at 113 Walleye** Howardwick, Texas. Price \$600.00

**REAL ESTATE**

**Charming cabin in the woods** 249 Palacio Dr., Howardwick, Texas. Two Bedrooms, one bath, mature landscape, fully furnished. Price: \$57,000.00.

**Updated cottage 420 S. Clarendon, Texas** Two bedrooms, one bath, attached one-car garage. Price: \$40,000.00



**Batting up support**

The winners of the Donley County Senior Citizens Softball fundraiser tournament held Saturday, August 2, 2014 were (Back) Patrick Shatswell, Lee Stegall, Brent Gains, Charles Harris, Dustin Shatswell, (Front) Brenna Buker, Bobby Wright, Brandon Richards, Nathan Floyd, Caitlyn Christopher, Krista McClelland.

COURTESY PHOTO

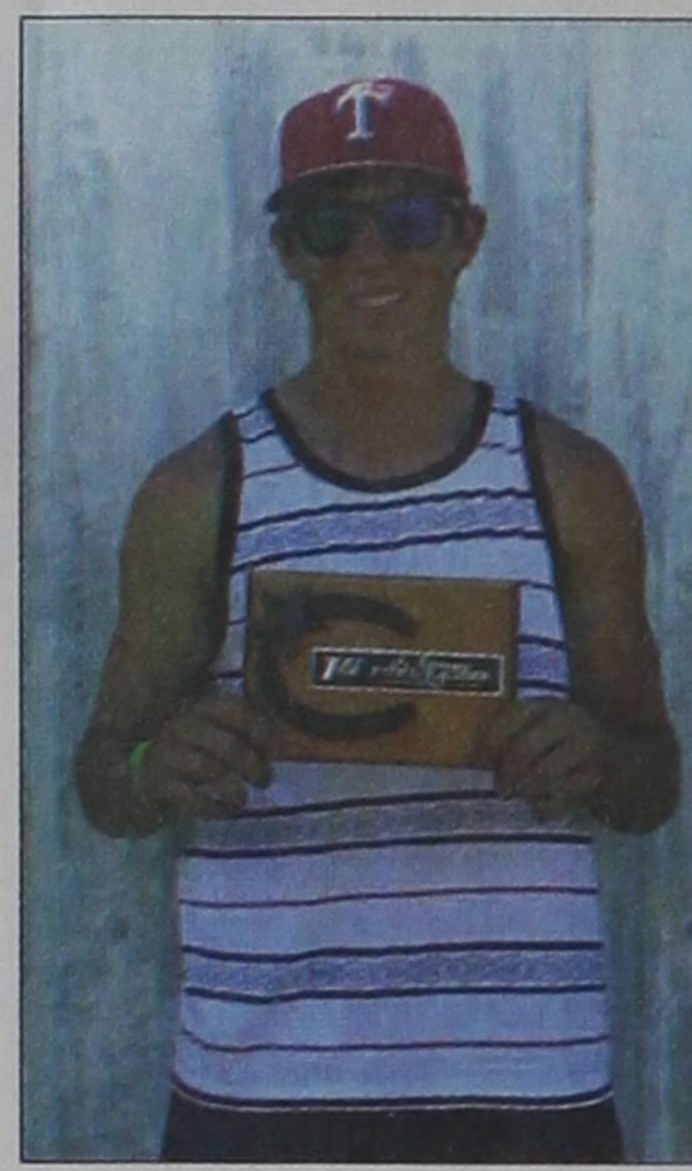

Gage Nelson and DJ Covey (not pictured) won the Horseshoe tournament held last Saturday as a fundraiser for the Donley County Senior Citizens.

COURTESY PHOTO

**Sandell Drive-In**  
**PLANES + FIRE & RESCUE**  
 All tickets \$7.00  
 Show starts at dusk.  
 Gates open at 7:30.  
 Friday, Saturday  
**August 8th & 9th**  
 Like us on facebook or check us out at [www.sandelldrivein.com](http://www.sandelldrivein.com)

**Germania INSURANCE**  
**Joey & Brenda Lee**  
 Lee's Insurance  
 PO Box 189 • Clarendon, Texas 79226  
**806.874.2130**  
 HOME • AUTO • LIFE • COMMERCIAL

*Follow us...*  
*to a website for all*  
*your local news.*  
**ClarendonLIVE.com**

**LOW BUCK STORAGE**  
**822-0442**

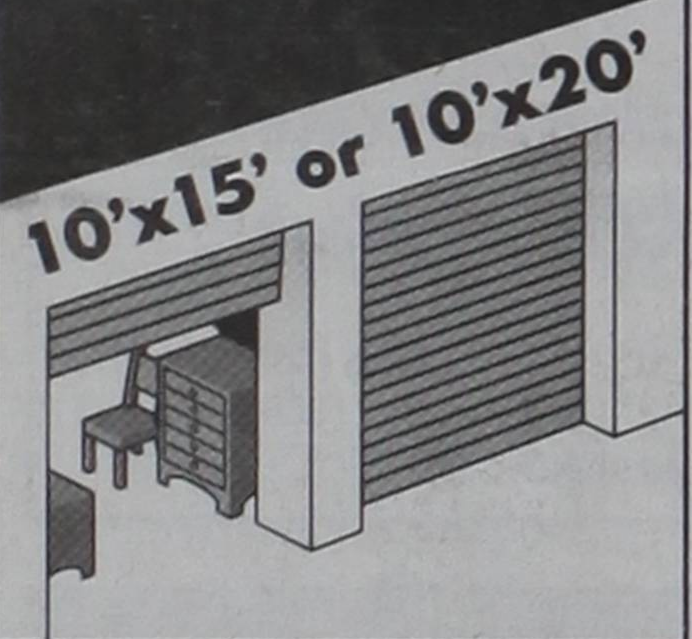

**Country BLUE BED & BREAKFAST**  
*Now Taking Reservations.*  
 3 Bedrooms  
 Max Occupancy: 7  
 Comfortable Living & Dining Room and kitchen.  
 Reasonable Rates  
**806.874.3937**  
 or **806.662.2544**  
 SUE LEEPER  
 618 S. PARKS ST.  
 CLARENDON

**weather report**

Day	Date	High	Low	Prec.
Mon	28	72°	63°	.43
Tues	29	81°	64°	.56
Wed	30	82°	60°	.03
Thur	31	79°	57°	-
Fri	1	83°	59°	-
Sat	2	89°	58°	-
Sun	3	90°	62°	-

Total precipitation this month: 4.13"  
 Total precipitation to date: 11.97"

**weekend forecast**

	Fri., August 8	Mostly Sunny	99° / 73°
	Sat., August 9	Mostly Sunny	97° / 73°
	Sun., August 10	Mostly Sunny	85° / 64°

Information provided by:  
 Lori Howard  
 National Weather Service

**FRIDAY & SATURDAY**  
  
**AUGUST 8 & 9**

**ROCK & ROLL COWGIRL or ROCK 47 JEANS**  
 BUY TWO **GET 1 FREE**

**20% OFF LADIES' TOPS**

**20% OFF GIRLS' TOPS & JEANS**

**20% OFF BOYS' SHIRTS & JEANS**

**20% OFF MEN'S SHIRTS**

**20% OFF CINCH JEANS**

**10% OFF BOOTS & SHOES**

**SHOP OUR \$10 RACK**

**CORNELL'S COUNTRY STORE**  
*So Much More Than A Feed Store.*  
**www.CornellsCountryStore.com**  
 903 E 2nd in Clarendon • 806-874-6773  
 Offers exclude sale items and baby items. Tax-free shopping applies to clothing and shoe purchases under \$100.

TEXAS STATEWIDE CLASSIFIED ADVERTISING NETWORK  
**TexSCAN**

**TexSCAN Week of August 3, 2014**

**BUSINESS OPPORTUNITY**  
 OWN YOUR OWN Medical alert company. Be the first and only distributor in your area! Unlimited \$ return. Small investment required. Call toll free, 1-844-225-1200.

**DRIVERS**  
**AVERITT EXPRESS** New Pay Increase For Regional Drivers! 40¢ to 46¢ CPM + Fuel Bonus! Also, Post-Training Pay Increase for Students! (Depending on Domicile) Get Home EVERY Week + Excellent Benefits. CDL-A required. 1-888-602-7440 Apply @ AverittCareers.com EOE - Females, minorities, protected veterans, and individuals with disabilities are encouraged to apply.

**DRIVERS SHORT HAUL** and regional/trailer jobs start now! Top pay, paid holidays, paid vacations, guaranteed hometime, and great benefits. CDL-A. 1-877-261-2101 www.schilli.com

**DRIVER TRAINEES NEEDED** now! Learn to drive for Werner Enterprises. Earn \$800 per week. No experience needed. Get your CDL and pre-hire now. 1-888-734-6710

**PARTNERS IN EXCELLENCE OTR** drivers, APU equipped, pre-pass, EZ-pass, passenger policy, 2012 and newer equipment. 100% NO touch. Butler Transport 1-800-528-7825; www.butlertransport.com

**PAID CDL Training!** No experience needed. Stevens Transport will sponsor the cost of your CDL training. Earn up to \$40K first year and \$70K third year. Excellent benefits, 1-888-726-4130, www.becomeadrivers.com. EOE

**\$2000 BONUS!** Oil field drivers. High hourly and overtime. Class A-CDL/Tanker. 1-year driving experience Home 1 week monthly. Paid travel, lodging, Relocation NOT necessary. 1-800-588-2669 www.tttransports.com

**HELP WANTED**  
**HEALTHCARE JOBS** Now hiring: RN's, LPN's/LVN's, CNAs, Med Aides \$2,000 bonus, free gas. Call AACO, 1-800-656-4414 Ext. 52

**HOME FINANCING**  
**MOBILE, MANUFACTURED, MODULAR** home financing specialists! Home and land or home only programs. No credit, bad credit No SSN!! All OK! 1-888-623-3356 LMLS ID#616308; www.MHFinancingSpecialists.com (RBI35417)

**SCHOOL/TRAINING**  
**AIRLINE CAREERS** begin here. Become an Aviation Maintenance Technician. FAA approved training. Financial aid if qualified. Housing and job placement assistance. Call Aviation Institute of Maintenance, Dallas: 1-800-475-4102 or Houston: 1-800-743-1392

**HVAC TECHNICIANS** 4 week accelerated hands-on training program. We offer 6 national certifications and lifetime job placement assistance. VA benefits eligible! 1-877-994-9904

**REAL ESTATE**  
**3 BEDROOM DOUBLEWIDE** on one acre. Financing available, cash purchase discount. The perfect location and floorplan. Call Keith at 1-830-443-9037, RBI#33557

**30-70 ACRES**, Southern Val Verde County. Hunting/recreational property. Good cover, deer, turkey, jayelina, quail. Near Lake Amistad. Starting at \$1562/down, \$285/month, 9%, 20-years. 1-800-876-9720. www.ranchenterprisesltd.com

**LOOKING TO SALE** land? Reach over 2-million readers for one low price in the Texas Statewide Advertising Network. Contact this newspaper or call 1-800-749-4793 for more detail.

**TEXAS HILL COUNTRY HUNTING** reduced for quick sale. Private wooded home site \$19,900. 18 hole golf course, lake, resort style pool, new clubhouse. Financing available. 1-877-886-7575.

**Run Your Ad In TexSCAN!**  
 Statewide Ad.....\$550  
 290 Newspapers, 871,154 Circulation  
 North Region Only.....\$250  
 93 Newspapers, 297,505 Circulation  
 South Region Only.....\$250  
 97 Newspapers, 366,627 Circulation  
 West Region Only.....\$250  
 98 Newspapers, 205,950 Circulation  
 To Order: Call this Newspaper direct, or call Texas Press Service at 1-800-749-4793 Today!

NOTICE: While most advertisers are reputable, we cannot guarantee products or services advertised. We urge readers to use caution and when in doubt, contact the Texas Attorney General at 1-800-621-0508 or the Federal Trade Commission at 1-877-FTC-HELP. The FTC web site is [www.ftc.gov/bizop](http://www.ftc.gov/bizop).  
 Extend your advertising reach with TexSCAN, your Statewide Classified Ad Network.

*We are passionate about your health.*

*Early Detection can SAVE YOUR LIFE.*

**Yearly Peace of Mind** - If you're over 35 and have been putting off your annual mammogram...call today for an appointment that could save your life.

Digital mammography Close to Home.

**APPOINTMENTS AVAILABLE FOR THIS MOBILE LOCATION**

**Lowe's Family Center** Monday, August 25  
 401 US Hwy 287, Clarendon 8:30 a.m. - 5:30 p.m.

**CALL NOW 1-800-377-4673**

Call 1-800-377-4673 to schedule your mammogram the next time our mammography coach comes to your city or for an appointment at the Harrington Breast Center in Amarillo.

Businesses, clinics and hospitals throughout the region are encouraged to invite the Mobile Mammography Coach to come to their location to offer breast screening services.

**HARRINGTON Breast Center**  
 A Department of **HBSA Hospital**

1310 Wallace Blvd. • Amarillo • [harringtonbreastcenter.org](http://harringtonbreastcenter.org)  
 806-356-1905 • 800-377-4673

Like us on Facebook! [facebook.com/HarringtonBreastCenter](https://www.facebook.com/HarringtonBreastCenter)