

Merry Christmas

# The Castro County News

70th Year—No. 37

Dimmitt, Texas, Thursday, December 22, 1994

50¢

34 Pages Plus Supplements

## More families offer greetings

Several Dimmitt and Hart families donated money to Christmas card projects in their respective communities, but were too late to have their names listed on the Community Greeting Cards published in this week's issue of the News.

Those from Dimmitt wishing their friends a Merry Christmas and Happy New Year include:

Emmett & Sue Broderson & Joylynn  
 Steve & Vicki Buckley, Dustan, Derek, Deacon & Chelsea  
 Donny & Melissa Carpenter  
 Bob and Wanda Murdock  
 Mrs. Joe Scott  
 Ruth O. Slough  
 Betty & Truman Touchstone

Hart residents who want to wish their friends Season's Greetings are:

Gerald & Joan Aalbers  
 Annie Bell  
 Paul & Irene Brooks  
 Jimmy Ray & Greta Davis  
 Carole Dyer  
 E.E. Foster  
 Wamon & Mary Foster  
 Barry & Rhonda George & Family  
 Harry & Betsy Gensburg  
 Cecil Ray & Louise Jones  
 Alan & Shane McLain  
 Nell Swopes  
 Don & Neoma Williams & Rachel Wall



**AWAY IN A MANGER**—Angels gather with Mary, Joseph and Baby Jesus in the manger scene in Holy Family Church's Christmas Pageant. The pageant was staged Sunday and Monday nights at the church, with parishioners recreating the Christmas story through acting, narrations and music. Portraying Mary in this year's pageant was Kirsten

Verkamp, (center, seated) and her husband (with staff), Harold, portrayed Joseph. Angels included (left side, from bottom) Susan Kern, Lesley Brockman, Susan Lange and Laura Birkenfeld; and (right side, from bottom) Kimberly Brockman, Jessica Kern, Kira Ball and Vanessa Wilhelm. Photo by Anne Acker

## Charges filed in theft of Christmas tree

The Grinch hasn't stolen Christmas yet, but a woman was charged Tuesday by Dimmitt police, alleged to have stolen a Christmas tree.

A 42-year-old Dimmitt woman is alleged to have sent her children into a convenience store to distract the clerk while she took a Christmas tree from in front of the store. The clerk told police she saw the woman take the tree despite the action of the children, whom the clerk alleged were trying to distract her on purpose.

The woman was charged with a Class B misdemeanor of theft over \$20 and under \$500. That is subject to a fine of up to \$1,000.

Police said the clerk told them that if the woman had asked, she might have given the woman the tree. Police said the woman told authorities she could not afford a tree.

Police were busy Thursday with two injury accidents in less than an hour.

The first occurred at 2:54 p.m. Thursday when a 1983 Chevrolet Celebrity station wagon driven by Bessie Lynn Andrada, 22, of Dimmitt, was struck by a 1993 Chevrolet pickup driven by Laura Bradford, 14, of Dimmitt. Bradford was cited for running the yield sign as she went east through the intersection of SW Fourth and Grand; Andrada was ticketed for no liability insurance.

One person in each vehicle was slightly injured.

About 50 minutes later, 14-year-old Joel Townsend was injured when the motorcycle he was riding on private property near the "Y" in south Dimmitt flipped.

Townsend was riding his cycle and crossed an alley. The motorcycle hit a small rise on the south side of the alley and went airborne, throwing Townsend off the motorcycle.

He was treated for injuries here and transferred to another hospital for an MRI. When no other serious

(Continued on Page 14)

## County ups assistant CEA's vehicle stipend

Castro County is in the market for a new assistant county Extension agent to replace Bryan Reynolds, who recently left to accept a job as county Extension agent in Tahoka, and commissioners will meet a prospective candidate for the job Tuesday afternoon.

Dr. Bob Robinson met with commissioners in a special called meeting Monday and told commissioners he has 60 qualified candidates for an assistant county agent's position, and he has one individual in mind for Castro County.

The county pays its assistant agents a salary of \$4,326, with additional amounts for a car allowance, association dues, show expenses, etc. The agents are actually state employees, so the majority of the agents' salaries comes from the state, along with insurance,

worker's compensation premiums, etc.

Robinson explained to commissioners that Castro County has the "lowest funded travel position" in the area and he presented commissioners with figures from Reynolds' last 12 months of service to Castro County. During a year's time, Reynolds traveled 24,430 miles, and 80% of those miles were traveled in his personal vehicle. The county paid Reynolds \$250 per month for a vehicle allowance since he used his own vehicle.

Robinson said Castro County is the only county in this district that does not furnish its assistant agent with a vehicle. He said if the county would raise its reimbursement rate to agents using their own vehicle for business travel, more applicants would consider the job.

After discussing how an increase would affect the county's budget, commissioners decided the county could swing an extra \$100 per month for the assistant agent's car allowance, and agreed to raise it to \$350 per month.

Robinson also told commissioners he had one candidate he thought

would be a good assistant agent for Castro County and told commissioners he would like to introduce the individual to them. Commissioners agreed to schedule a special meeting Tuesday at 1 p.m. to meet the prospective agent, who Robinson said is a Texas Tech graduate and hails from the Robert Lee area.

## News changes deadlines

Deadlines have been changed for the Dec. 29 issue of the *Castro County News*.

The News office will be closed Friday and Monday for the holidays. Persons with non-breaking news items, especially weddings and engagements and news about showers, must have those items submitted by 2 p.m. today (Thursday).

Other items which have a normal Monday deadline should be submitted by 9 a.m. Tuesday, including news from community correspondents.

The deadline for all advertising is noon Tuesday. Advertisers who have not been contacted will be contacted today (Thursday) or Tuesday morning.

## 1:1

By Don Nelson

We lost a great lady last week. I'll never forget what Jack Howell said about Juanita Bruegel once during a Junior Livestock Show sale. He was auctioning one of her grandchildren's show animals and teased her into going higher and higher on her "grandma bid."

After she had won the bid, he complimented her on being a good sport, then remarked, "You know, I liked and respected a lot of my friends' parents when I was growing up, and I still do. But Juanita Bruegel has always been my friend."

He spoke for a lot of us.

To those of us who grew up with the Bruegel kids, Juanita was a hard-working, forthright, down-to-earth, level-headed friend who shared our lives with a genuine interest and concern. She always seemed glad to see us, and would usually stop what she was doing and take the time to visit with us. She never talked down to us. Every one of us seemed to have value in her eyes, and she was generous with her compliments and encouragement.

She had a good life. It wasn't an

(Continued on Page 14)



**SEARCHING FOR SPEEDERS**—Dimmitt Police Chief Dewayne Haney checks out the city's new radar system on Monday. The new system replaces a unit that was over 20 years old that Haney had not allowed officers to use for several months. The unit is already at work around town. Photo by John Brooks

## New radar system ready for speeders

The white car and black pickup come whipping around the curve and go hurtling through the school zone on West SH 86 at a good 45-50 mph.

Suddenly the pickup's brake lights flash, although there are no police cars in sight.

The pickup probably has a radar detector. The car doesn't, and is subject to getting a speeding ticket thanks to the city's new radar unit.

Unlike the city's old radar gun, which is 20 years old, this unit is easily calibrated and very accurate, according to Police Chief Dewayne Haney.

"This is the first new radar equipment we have had in 20 years," Haney said. "The old one was so out of date I didn't even want the officers using it."

All of the officers can use the new unit, which Haney was able to buy for half of what was budgeted. It came through at the state bid price, which was half of the going retail rate. The savings was enough

so the city will buy another next month.

The new unit has a special switch that a patrolman can flick on in an instant. That means the radar doesn't have to be sending out a steady beam that might alert speeding motorists.

Haney showed off the unit on Monday, going north on US Highway 385. Truckers were caught unaware, coming through the city at 50 mph and better.

"The department's goal is to slow traffic in the school zones for our children who have to walk to and from school," Haney said. "We also want to slow traffic down on 385 and 86. We have received numerous complaints on trucks speeding through town. I hope we use this radar system to accomplish that goal."

"Since I took over as chief 13 months ago I have worked to get the department up to the level of professionalism that it ought to be. This is one step toward that level."

**Dreaming of a White Christmas? Keep dreaming!**

Readings taken every day at 7 a.m. at KDHN, official National Weather Service recording station for Dimmitt.

Thursday	..... 57	..... 20
Friday	..... 52	..... 24
Saturday	..... 54	..... 21
Sunday	..... 61	..... 17
Monday	..... 61	..... 19
Tuesday	..... 68	..... 21
Wednesday	..... 67	..... 20
December moisture	.....	..... .03
1994 moisture	.....	..... 19.89



# Op-Ed

Letters

Opinions

Columns

Features



## A View From the Hill

By Congressman BILL SARPALIUS

### Eternally grateful

I have been in public service for 14 years—eight years as a State Senator and six years as a Member of Congress. I will be eternally grateful for the opportunity that you have given me to try to make a difference in our state and country.

I am proud of the accomplishments that we have achieved together. Those accomplishments have not been easy to obtain—the struggles to pass a strong DWI bill which has saved thousands of lives across Texas, creating the Texas Commission on Alcohol and Drug Abuse which set up hundreds of alcohol and drug treatment facilities across Texas, setting up farm and ranch loan programs to help beginning farmers and passing di-

saster assistance for those farmers in their time of need were all battles I was privileged to fight. None were easy, but they were extremely rewarding. I am proud of our successes and seeing this district grow and prosper with unemployment currently at the lowest rate ever and opportunities for growth have never been higher.

I have worked hard in this job, giving up countless weekends and holidays and working long hours, but to help a constituent in their time of need has been most gratifying. You gave me that opportunity to serve and I will never forget it.

I cannot help but reflect back to when I was 10 years old and my mother, two brothers and I were basically homeless. The only food

and clothing we received were given to us by churches. Now, I am leaving the office of United States Congressman. Only in this country can a person who has nothing become something. As a child, I had lofty dreams and you gave me the opportunity to make those dreams come true.

I have always believed that when the Lord closes one door, he opens another. I don't know what the future holds, but I know who holds the future and if it is His will, I may be in public service again someday.

Thank you, again, for bestowing upon me the highest honor that I could have achieved—to work for the people of the 13th Congressional District of Texas.

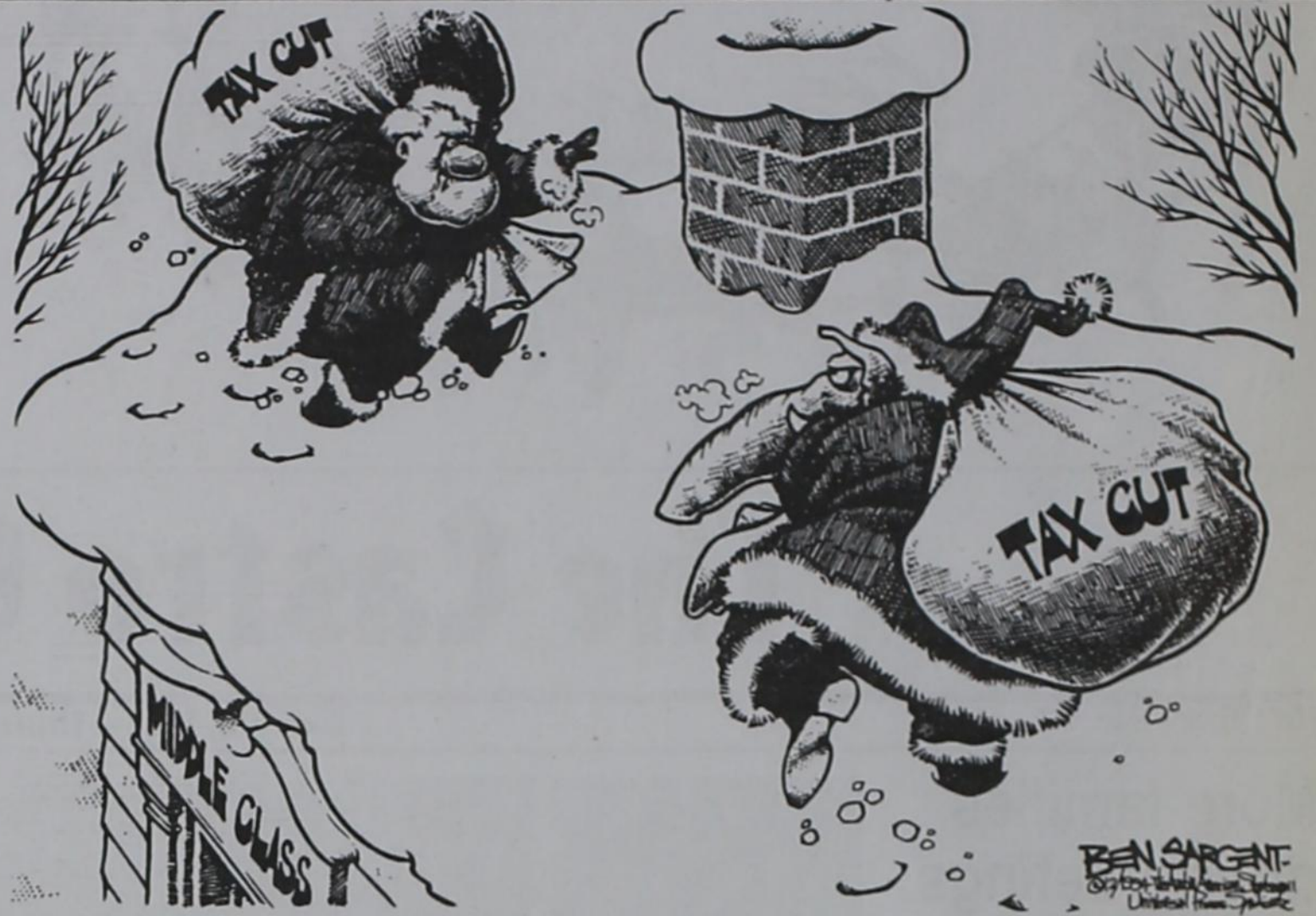

## Taxpayer relief coming?

By PHILIP C. CLARKE

Some welcome relief may be coming for the overburdened taxpayer. The new Republican-controlled Congress promises to re-examine the tax code with an eye to providing a break for savings and investments.

Among industrialized countries, the US ranks near the bottom in personal savings rates. Using data from the Organization for Economic Cooperation and Development, the US savings rate is 4.3% of personal disposable income, down from 8.1% in 1980. That's compared with current double digit

rates in Japan, Germany, France, Italy and Canada.

According to *Investor's Business Daily*, part of the reason for America's low savings rate is our relative wealth. Because Americans have a greater personal income than citizens of most other countries, their savings as a percentage of income naturally tend to be lower. But another factor that needs changing is the way our government taxes savings and investment.

When individuals save money, for instance, they must pay taxes on any income earned as interest. If the individual sells that investment for a profit, that profit is also subject to capital gains taxation. Moreover, all of these taxes come on top of the regular income taxes that individuals must pay when they earn the money they want to invest. In other words, this money is double- and sometimes triple-taxed.

And that's just the negative side. Consider the tax breaks for Individual Retirement Accounts that Congress took away in 1986. To encourage savings, the government used to allow anyone to put away \$2,000 per year and deduct that amount from income. But the 1986 Tax Reform Act severely limited who could claim the deduction. For example, any individual earning more than \$25,000 a year could not take the IRA deductions. Nor could anyone who worked at a company with a pension or other retirement plan.

But Republicans, particularly those in the House of Representatives, are talking about changing these disincentives to savings by changing the tax code. For instance, Congressman Dick Arney of Texas has proposed a "flat tax" plan that would exempt dividend and interest income as well as capital gains. And Congressman Bill Archer, another Republican from Texas, has offered his own tax reform proposals. Archer, who's in line to head the House Ways & Means Committee, wants first off to reduce the tax on capital gains and index them to inflation. More importantly, he wants to

move away from taxes on income altogether to a tax on consumption—a sort of national sales tax.

Such reforms aim at reducing taxes on productive activities like work and savings. In addition to reducing such taxes, simplifying the tax code—whether by introducing a flat tax or a national sales tax—would greatly reduce the costs associated with complying with current tax laws.

For example, according to the government's own figures, people spend more than 4 billion hours a year just filling out their tax forms. If you estimated that people's time is worth \$20 an hour, that means that our society spends some \$80 billion a year wrestling with tax forms. And while a national sales tax might involve more paperwork than a flat tax, it still would be much simpler than the current system with all its dozens and dozens of thick instruction and rule books.

Whatever the new Congress comes up with, it's heartening that at least some of our lawmakers are now willing to consider changing the rules to reward savings and investment.

### Letter

## Against

Dear Editor:

I usually enjoy reading the local paper on a weekly basis, but last week I read a story the *News* covered on the school nursery and I felt that the public read only part of the story. While the school board approved the purchase of the nursery as a unit, there was a vote taken and it was not unanimous.

Now I was elected to the position of school trustee by a group of people that trusts me to vote for them and to represent their interests as best as I can. I am trying to do that but I don't think they realize this if they only get part of a story or incomplete reporting.

You very carefully reported the cost of the nursery and other negative aspects but you failed to report the vote taken. So I know I would appreciate it, and I think the public would also, if these facts were not lost in the printing.

Again, I enjoy the effort you take in printing the *Castro County News*, but I just believe that this was something that needed to be said.

EARL BEHRENDIS  
(Editor's note: Mr. Behrendis voted against purchasing the building for the nursery.)

### Letter

## Memories

Dear Editor:

Christmas tends to bring on old memories that are especially dear. As I try to raise my children, I am reminded of Dimmitt and the love that was showered on me as a child.

The kids love to hear stories about when mom and Uncle Jeff were little and I have lots to share.

The stories include playing with Deannea's and Judith's do-do curls in church to stopping and parking a tractor in the middle of the road because I had a flat and water was going everywhere.

The dearest memories always include friends and parents who took time to share their lives with me: Mrs. Dennis bringing potholders over before my marriage and telling me stories about when she and Mr. Dennis first married; learning how to ski with the Merritts; and sports with my parents in tow. How could anyone have any better memories.

Dimmitt is not "home" anymore yet it will always have a very special place in my heart. I love you all and wish you the merriest of holidays. May God bless your homes with laughter and joy as we celebrate His son's birth.

With all my love,  
KIM WATTS POND

State Capital

**HIGHLIGHTS**  
By Lyndell Williams & Ed Sterling  
TEXAS PRESS ASSOCIATION

**AUSTIN** — Lt. Gov. Bob Bullock, who vowed to foster more bipartisan cooperation in the upcoming 74th Texas Legislature, knocked off the task of naming Senate committee appointments a solid month before the session convenes Jan. 10.

Bullock, a Democrat, named five Republicans as committee chairmen — three more than last session. New appointments include Sen. Teel Bivins of Amarillo, Nominations; Sen. David Sibley of Waco, Economic Development; and Sen. Chris Harris of Arlington, Administration.

Reappointed as chairmen were Republican Sens. Bill Ratliff of Mount Pleasant, Education, and Don Henderson, of Houston, Jurisprudence.

As Nominations chairman, Bivins will lead the committee that will consider Republican Gov.-elect George W. Bush's 3,000 appointments to state boards and commissions. Bivins' committee will also be charged with confirming some 600 appointments that the outgoing Democratic administration has made.

Bush's communications director Karen Hughes told the *Austin American-Statesman*, "The lieutenant governor said he wants to run the Senate in a bipartisan way, and this is evidence of that spirit of bipartisan cooperation."

Sibley takes over the Economic Development chairmanship formerly held by the powerful Sen.

Carl Parker, D-Port Arthur, who was defeated in his bid for reelection. The committee considers bills related to business.

Democrats still hold the edge in the Senate, with 17 members to the Republicans' 14.

### Run on TexPool

In a matter of a few days last week, state and local officials withdrew more than \$1.5 billion from TexPool, an investment pool managed by the Texas Treasury.

Many depositors reportedly are taking their money out because interest rates offered by the Treasury Department are lower than those offered by investment funds elsewhere and the Orange County debacle provided an additional kick.

To counteract the massive pull-out, the Treasury has begun using state funds to buy investment securities and paying depositors who wish to withdraw funds at the original price they paid, rather than the present market value, which is lower.

Although finance experts maintain that the TexPool is a safe place to invest tax dollars, state and local government officials continue to make withdrawals, in part due to the highly publicized bankruptcy of Orange County, Calif.

State Treasurer Martha Whitehead said depositors can withdraw any or all of their money and the interest due them from TexPool. "I am confident we will weather this storm and calm any concern raised due to the irresponsible and unjust comparisons to the Orange County situation," she said.

### Child Support Bill Resurfaces

Rep. Toby Goodman, R-Arlington, co-chair of the Joint Interim Committee on the Family Code, is carrying a bill proposed by Attorney General Dan Morales to bolster efforts to collect support from deadbeat parents.

A similar bill failed in the 1993 legislative session, but chances are improved that such a bill will pass in 1995 with the support of Gov.-elect Bush and the endorsement of Comptroller John Sharp.

The bill would allow the state to revoke driver's, professional and

other state licenses and permits from residents who don't pay or are late in paying court-ordered child support.

### New Insurance Commissioner

Outgoing Gov. Ann Richards has appointed Rebecca Lightsey, executive director of a state health insurance pool, to replace J. Robert Hunter, who resigned as Texas insurance commissioner.

As head of the Texas Department of Insurance, Lightsey will serve the remainder of Hunter's term, which expires Feb. 1. That's all the time she needs to approve a change in the state benchmark for automobile insurance.

Lightsey told the Associated Press she would honor Hunter's commitment to Gov.-elect Bush not to start rate hearings until after Jan. 1.

### Budget Watchdogs Named

Gov.-elect Bush last week appointed a three-man budget team that he says will help serve as a taxpayers' watchdog on state spending.

Bush, who takes office Jan. 17, appointed Lubbock accountant Mike Weiss to serve as director of fiscal policy.

Wise, 50, named Albert Hawkins, currently deputy director of the Legislative Budget Board, as budget director and said Jim Oliver, former budget director, would serve as senior budget advisor.

"This budget team combines the very best of the public and private sector, and brings together the brightest budgetary minds in the state of Texas," Bush said.

### Other Highlights

■ San Antonio's hopes of bringing the 1996 Republican National Convention to the Alamo city received a setback last week as a party committee opened negotiations with San Diego. The convention would be the GOP's first in California in 30 years.

■ U.S. District Judge Filemon Vela of Brownsville says he is leaning toward throwing out a state lawsuit that seeks more than \$5 billion from the federal government for the costs associated with illegal immigration.

## The Castro County News

647-3123 [FAX 647-3112] PO Box 67, Dimmitt, Texas 79027

Published each Thursday in Dimmitt, Texas, by the News Publishing Co., 108 W. Bedford. Second Class Postage Paid at Dimmitt, Texas. Publication Number 092980.

Subscription Rates—One year \$16.00; school year \$13.50; six months \$9.00.

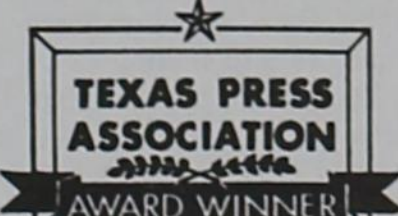

Member of the Texas Press Association, West Texas Press Association, Panhandle Press Association and National Newspaper Association.

### DEADLINES

Display and Classified Advertising.....Tuesday Noon  
Agriculture, Business & Industry News.....10 a.m. Monday  
Sports, Social and Church News.....Monday Noon  
Community Correspondence.....Monday Noon  
Personal Items.....5 p.m. Monday  
General News, City and County.....Tuesday Noon

Editor and Publisher.....Don Nelson  
News Department.....Anne Acker, John Brooks  
Advertising Composition.....Paula Portwood  
Page Composition and Photo Lab.....Linda Maxwell  
Bookkeeping.....Anne Acker, Paula Portwood  
Community Correspondents.....Mary Edna Hendrix, Dimmitt;  
Virgie Gerber, Nazareth; Teeny Bowden, Sunnyside



Last Puzzle Solution

WAGS, TIGOT, TIRE, HOSE, OUTLAND, TROPHY, UNO, HORSETHIEF, TD, MARY, CHITAL, SAHARA, TERM, JOEL, RO, AMT, NEFFIELD, CIARR, PLOD, PLAT, GARRET, HANO, HLOD, ESOS, YORE, LURE, LETUIS, LOW, UP, ONLY, HELLEN, ANN, UNPA, SEALED, ROSSPEROT, SKI, TIME, ROD, TIN

**ACROSS**

- TXism: "an ornery old \_\_\_" (mean)
- 5 fed. safety agency
- 6 chicken fried steak, fried okra & tea
- 7 in Van Zandt Co. on 80: \_\_\_ wood
- 8 rater of TX TV: \_\_\_ Nielsen Co.
- 9 TXism: "brave \_\_\_ rodeo clown"
- 12 TXism: "faster than a prairie fire with \_\_\_ wind"
- 17 TX Tommy Lee Jones film: "\_\_\_ Born Killers" ('94)
- 20 TXism: "it's \_\_\_ than Texas" (large)
- 22 TXism: "duster"
- 23 prenatal status of rare TX bird (2 wds.)
- 24 TXism: "\_\_\_ red handed"
- 29 TX has \_\_\_ belt law
- 30 TX cafe: "Good \_\_\_"
- 31 TX wildflower
- 32 TX Willie Nelson wrote "Hello \_\_\_"
- 36 TXism: "hard \_\_\_ keeps the fences up"
- 37 former Rangers pitcher Scott
- 43 Wursthfest is TX's biggest \_\_\_
- 45 TX Eatherly flew scout plane for \_\_\_ Gay bomber
- 47 half of TX mohair goes to this continent
- 48 "How 'bout \_\_\_ Cowboy?" rebukes
- 51 Galveston blesses the shrimp fleet in \_\_\_ June
- 52 mechanical bull: El \_\_\_
- 53 TXism: "don't cotton \_\_\_" (dislike)
- 54 this Premier directed TX Tierney in "Laura"
- 55 honorary TX Ranger: \_\_\_ Stanley Gardner
- 56 TXism: "\_\_\_ snake can still bite" (beware)
- 58 Finke, TX hosts National \_\_\_ Day
- 59 TXism: "I'm \_\_\_ up!"
- 60 Sam Rayburn served 48 of 'em in Cong. (abbr.)

**DOWN**

- 1 tapt on Gonzales flag in 1835 (4 wds.)
- 2 previously owned auto (2 wds.)
- 3 carpet type
- 4 Foley's "Red Apple" \_\_\_
- 9 Abilene's \_\_\_ code is 915
- 10 it sticks to your teeth (3 wds.)
- 11 San Antonio won \_\_\_ American city Award in '83
- 12 "Honest \_\_\_"
- 13 Wichita Falls paper: \_\_\_ News
- 14 in Nueces Co. on 44: \_\_\_ Dulce
- 15 TXism: "\_\_\_ your drift" (understand)
- 16 TXism: "could talk the \_\_\_ off an iron stove" (talkative)
- 18 Texans Detmer and Murray
- 19 Mavericks '85 draft pick: \_\_\_ Blab
- 21 a TX Gatlin (init.)
- 24 Gov. \_\_\_ Culbertson
- 25 this Zapruder shot film of JFK assassination (init.)
- 26 union at GM plant in Arlington
- 27 Waco hosts "\_\_\_ Fest" in spring
- 28 Travis Tritt's \_\_\_ a Quarter..."
- 33 TX Pride's "\_\_\_ I Losing You?"
- 34 TX Willie platter
- 35 TX-based \_\_\_ Quinta
- 37 TX Burnett (init.)
- 38 in Williamson Co. on hwy. 79
- 39 TXism: "strike while the iron \_\_\_"
- 40 TXism: "worth his weight \_\_\_ (valuable)"
- 41 this Nick and TX JoBeth Williams were in "Teachers"
- 42 TXism: "dull as week-\_\_\_ soda pop"
- 44 TX Meredith Mac
- 46 TXism: "ugly \_\_\_ sin"
- 49 more morose
- 50 chicken fried \_\_\_
- 57 TXism: "tie up the loose \_\_\_"

**The Original TEXAS CROSSWORD**  
by Charley & Guy Orbison  
Copyright 1994 by Orbison Bros.



# On the Go

With Mary Edna Hendrix, 647-3343

Merry Christmas to all! The Christmas parties have been in full swing and it is so exciting. Castro County elected officials, county employees and their spouses enjoyed a Christmas dinner of turkey and dressing and all the trimmings Dec. 14. About 85 people attended the luncheon at the Senior Citizens Center. Mary Cluck catered the dinner.

The outgoing elected officials were recognized and plaques were given to Commissioners Dale Winders, Pct. 2, Jeff Robertson, Pct. 3, Joy Jones, county-and-district clerk, and Polly Simpson, county judge, in appreciation for their years of dedicated service to the county. Bill Sava wrote a poem in behalf of Polly, entitled *An Angel's Work is Never Done*. Jeff and Karen Robertson read the poem. Karen was dressed as an angel. Jonalyn

Jones of Hart did a portion of the poem in calligraphy. It was framed and presented to Polly from the commissioner's court.

New elected officials for 1995 will be Larry Gonzales, Pct. 2 commissioner; Bay Baldrige, Pct. 3 commissioner; Joyce Thomas, county-and-district clerk; and Irene Miller, county judge.

Over 30 Pine St. neighbors attended the Pine St. Christmas party and home tour Thursday night.

They congregated at Randy Morgan's house for caroling, then viewed the homes of Dawn Goolsby, Sara and W.J. Hill and Shirley and Bill Newland before finishing the evening with refreshments at Diane and Glenn Halla's. Many agreed that this should become an annual event.

Saturday night the members of the First Baptist Church choir practiced for an hour and then went to the home of Bill and Shirley Newland for fun and fellowship. They had a table loaded with good food, chips and dips, candy and cookies. Another table held egg nog, coffee and soft drinks. The Newlands' daughter, Tonya, was home from college.

On Sunday the choir presented its cantata, *Come Celebrate Jesus*, a Christmas invitation led by Bill Newland. Soloists were Sandra Bagwell, *I Heard the Bells on Christmas Day*; Nikki Kenley, *Peace, Peace*; Alexis Proffitt, *Good Things Come in Small Packages*; Sue Achley, *Bethlehem Morning*; Debra Ball, *Silent Celebration*; Laura Wheelless, *What Wise Men Still Do*. Leslie and Frances Davis

were the narrators, Walter Maynard was pianist and Ronda Wise was organist. The Fifth Generation Boothe Granddaughters sang a special, *Heirloom*, to their grandmother, Johnnie Boothe, for her 80th birthday.

The Boothe family hosted a birthday reception for Johnnie on Sunday afternoon at the Senior Citizens Center. Aundrea and George Frye and their family of Friona; Mike and Prissy Boothe and family from Levelland; and Kim (George and Aundrea's daughter) served a pretty birthday cake and punch.

Christmas open house in honor of Mary Lou Frazier on her 90th birthday was held in the pretty home of Alvin and Frances Frazier. Cara Dearing, Alvin and Frances' daughter, was serving a pretty birthday cake and punch and the patio had a table loaded with cookies, candy, and a cheeseball with crackers.

Paul and Barbara Kenley held Christmas open house in their home on Sunday afternoon, assisted by the deacons' wives. Sue Summers and Debbie Annon served cookies, candy and fruit punch, and a table in the den held a delicious cheese log and crackers. Nikki Kenley and her roommate, Laura Wheelless, were home from college at Hardin-Simmons University.

The hospital auxiliary members met on Dec. 14 with Jackie McLeroy presiding. Gerald Hensley explained the coagulation instrumentation that the hospital needs. Members attending were McLeroy, Betty Freeman, Bea Hardy, Florene Leinen, Mattie Seale, Irene Carpenter, Gertie Waggoner, Mary Blackwood, Edna Reinart and Mary Edna Hendrix.

Lorann Hamilton was the hostess to the Thursday Bridge Club that met at the Senior Citizens Center. She served nuts, chips and dips for snacks and cake for dessert. Virginia Crider won high score and Alma Kenmore won second high. Others playing were Johnnie Vannoy, Emily Clingingsmith, Dugan Butler, Dude McLauren, Helen Braafladt, Elizabeth Huckabay, Edith Graef, Neva Hickey, Susie Reeves, Ina Rac Cates, Bernice Hill and Fernie Dickey.

Geneva Justice enjoyed a short visit from her granddaughter and her husband, Jennifer and Tucey Rankin of Amarillo. Jennifer teaches at Will Rogers Elementary and Tucey is a football and baseball coach at Tascosa High School. Jennifer is the daughter of the late Kenn Justice.

The Junior High Youth of First United Methodist Church met in the home of Garland and Susan Coleman. Eight youngsters read and talked about the Christmas story and enjoyed the fellowship and refreshments.

Jennifer Elms met with the Senior High Youth of FUMC. They played a Christmas game and enjoyed dips, chips and vegetable sticks.

Golden Acres Senior Citizens had its monthly birthday dinner combined with Christmas, on Dec. 13. There were 26 persons present, including three visitors. Visiting were Alrikia Moor and Gary J. Moore of Hart and Trudy Derrick.

Celebrating birthdays in December are Alrikia Moore, Cleo Parks, Lois Hollingsworth and Gladys Hampton. They were all treated to the singing of *Happy Birthday*.

Residents exchanged Christmas gifts.

Residents attending were Jettie Sheffy, Mary Cox, Mavis Tittle, Wreathel Green, Adell Clark, Inez Lee, Susie Reeves, Fern Morgan, Nora Buchanan, Alene Lilley, Una

Ward, Faye Ethridge, Ray Ethridge, Johnye Davis, Edith Richardson, Neva Hickey, Patsy Hudman, Grace Anderson, Opal Thomas, Bishop Woolbright, Helen Wilmoth, Rhea Killion, Lorene Beach and Ida Moore.

A good time was had by all.



### FIND "NEWSY"

We've hidden "Newsy" somewhere in the CASTRO COUNTY NEWS.

If you find him (and he may be any size, anywhere), come to the Castro County News office, 108 W. Bedford St., during business hours, 8-5 Monday through Friday.

The first two to come in and show us where they found "Newsy" in this issue will win a 2-liter bottle of soft drink. (One win per month, per family. No phone calls, please.)

Last week's winner:  
Saul Medrano  
Linda Martinez



THE SOLDIERS' SEARCH—Herod's soldiers, portrayed by Dwight Acker (left) and Micky Hochstein (right) discover two mothers (Carolyn Wilhelm and Kim Birkenfeld) attempting to hide their children during a scene from the Christmas

pageant staged by Holy Family Church in Nazareth Sunday and Monday evening. Other soldiers were played by Virgil Huseman and Mark Kleman and Dianne Huseman was cast as another mother with a child. Photo by Anne Acker

# Nazareth

WITH VIRGIE GERBER, 945-2669

Holy Family Church held its Christmas pageant Sunday and Monday evening in Holy Family Church with a good crowd enjoying the music and presentation.

Father Neal Dee, pastor of Holy Family Church, gave the welcome.

Thanks to the 90-plus parishioners who gave of their time and talent to present this pageant which has always meant a lot to the parish since it was started.

Bev Hill and Virgie Gerber enjoyed a Christmas program at Gene Howe Elementary School in Amarillo. It was presented by the first grade class, of which Eric Rose is a member. Tricia and Andrea Rose and Ed and Ruth Rose also attended and enjoyed the program.

Prayers are asked for Mary Acker, who is in High Plains Baptist Hospital being treated for a

stroke.

Supt. N. Dean Johnson was honored on his 50th birthday with a party at the Nazareth school. It was hosted by the teachers and other personnel.

An elementary Christmas program was enjoyed by many at the Nazareth school cafeteria last Thursday night. Kindergarten through third-grade students sang Christmas carols and the fourth graders presented a play, which was very entertaining. Thanks to Band Director Roger Myers for his work with these children.

A large group of Nazareth people enjoyed the "Tree of Life" Christmas pageant Sunday afternoon at the Civic Center in Amarillo, presented by Paramount Terrace Christian Church in Amarillo.

Many friends and relatives attended the wedding ceremony of Brant Baca and Michelle Berends at St. Anthony's Catholic Church in Hereford Saturday evening. A reception and dance were held at the parish hall.

The Christmas brunch held at the home of Jimmie Schulte Saturday morning was enjoyed by a group of Senior Citizen ladies. Delicious food, fellowship and lots of fun was enjoyed by all. The brunch was hosted by Jimmie Schulte, Norma Schacher, Betty Wilhelm, Florine Brockman, Nellie Wilhelm, Evelyn Rossi and Georgie Kleman.

Terrell Bogle and his friend, Loni Wert of Centre, Colo., spent a couple of days here with Terrell's grandparents, Leroy and Dorothy Pohlmeier.



THREE WISE MEN, WISE MEN THREE—Holy Family Church staged its Christmas pageant Sunday and Monday nights and portraying the Three Wise Men were (from left) Dwayne Acker, John Hochstein and Norman Gerber. More than 90

parishioners from Holy Family Church were involved in the production of the pageant, either as actors, narrators, makeup artists, choir members or acolytes. Photo by Anne Acker

**GET THE ALCO Advantage**

Store Hours: 9-7 Monday-Saturday, 1-5 Sunday

**FREE EVERY TUESDAY!**

SECOND SET OF PRINTS

Receive a second set of 3" prints FREE with any exposure roll of 35mm, disc, 110 or 126 color print film left for developing and printing at our everyday prices! C-41 process only. Excludes larger 4" size prints, and photo galaxy.

803 N. Broadway Dimmitt, TX

**We are**

Gary R. Hardee, M.D., P.A.

103 Front & Bedford Dimmitt, Tx. 79027 (806) 647-5162

FAMILY MEDICINE AND RURAL HEALTH CLINIC

**MERRY CHRISTMAS AND A HEALTHY, HAPPY NEW YEAR**

We will continue to do our best to serve you and your family throughout the New Year. Thank you for your continued support.

Dr. Hardee, Cenci, Beth Schulte, Carole Hopson, Suzan Sanders, Phyllis Mooney and Liz Murphy.



# People



STUDENTS OF THE MONTH at Dimmitt Middle School for December are (seated, from left) Jaci Bishop and Felicia Sanchez; (kneeling, from left) Lori Schulte, Olga Diaz, Victor Delgado and Coby Martinez; and (standing, from left) Jeannette Sanchez, Raymond Powers, Frederick Traylor and Emanuel Jaramillo. Photo by Anne Acker

## Calvert earns top position as A&M legislation director

Dr. Stanton Calvert, a Dimmitt native, has been named chief of legislation for the Texas A&M University System effective Jan. 2. Calvert has been executive director of the Texas Association of Community Colleges. He was named to the new position on Dec. 13.

All A&M system employees on the legislative team will report to Calvert, who will be the primary advocate for the TAMUS legislative program. Calvert will report directly to Dr. Barry Thompson, TAMUS chancellor, and will be based at the TAMUS office in Austin.

"Dr. Calvert has a long and

distinguished career in Texas higher education," said Thompson. "He has been involved in almost every facet of higher education in our state in his 25-year career, from the halls of academia to the halls of the state capitol. The A&M System is fortunate to have Dr. Calvert at the helm of our legislative effort."

Calvert, 51, has served in his current position since 1986. As executive director of TACC, he coordinates and represents community and junior college interests before the Texas Legislature and state agencies. He has been successful in developing a community college legislative constituency base by consistently organizing a cooperative legislative agenda for the 50 Texas community colleges.

Previously, he served as community college director and assistant to the commissioner of higher education at the Texas Higher Education Coordinating Board for seven years and as dean of the College of the Mainland in Galveston County for five years.

"Over the years, the legislative and executive leaders of this state

have committed themselves to a vision of excellence in Texas higher education," Calvert said. "I appreciate their vision and abiding financial support through the good times and, more recently, the lean times."

"I am honored to join with the Texas A&M University Board of Regents, chancellor, member agency directors and university presidents to continue to pursue this vision of excellence in teaching, research and public service."

Calvert, a graduate of Dimmitt High School and Abilene Christian University, pursued graduate studies in business and public administration and earned his PhD in higher education administration from the University of Texas at Austin.

He has served as a consultant, workshop leader and adjunct professor in higher education and finance at UT, the University of Houston and Baylor University.

He worked on the family farm (which his father, Carlos, still manages) while growing up. He and his wife, Ann, have three college-age sons.

## Sunnyside

WITH TEENY BOWDEN

Larry and Lori Duke and girls and friends, and Mike and Linda Bourland and boys of Lubbock visited Saturday with Robert and Frances Duke. Larry and Mike got in some pheasant hunting. Several friends visited with Robert and Frances on Saturday to hunt pheasants. They were from Canyon and Lubbock.

Myles and Gregory Sadler hunted pheasants with Embree Roy and Willie Mac Sadler on Saturday and spent Saturday night with them.

### Flagg 4-H holds meeting

Flagg 4-H Club held its Christmas party at Darrell Buckley's barn on Dec. 11 and each member brought a canned food and \$1 to purchase groceries to share with a family in the community.

Members attending enjoyed several games and refreshments. Each year the club does a Community Service project as part of its Christmas party.

Sherri Matthews, club manager, delivered a Brown Bag surprise on Monday, Dec. 12.

### Blood drive set Tuesday

Coffee Memorial Blood Center of Amarillo will hold a special blood drive Tuesday from 2 p.m. to 7 p.m. at the Dimmitt City Hall meeting room.

All eligible persons are urged to donate blood. Blood supplies are extremely low this year. Many persons are apparently fearful of donating blood, but giving blood is safe and simple. It can also assure a lifetime for a person with the same blood type.

Persons donating blood during the drive here will receive a "Holiday Hero" t-shirt.

Matt and Kristen, children of Laura Sadler, were baptized at New Covenant Church at Muleshoe. Tex and Norma Conard attended services with the Larry Sadler family. After church they all had dinner together with Ezell and Verba Sadler in the big house. Others attending were Anthony and Lori Sisemore and girls and Stacy Norman and boys.

Joan Durbin and LaWanda Wilson and girls, Gwyn and LaGlenda, attended the Christmas pageant at Nazareth on Sunday night. Joan played the part of Elizabeth in the pageant.

Gay and Verba Sadler went to the lake at Breckenridge on Wednesday to gather pecans and check on things. They came back Thursday in time to attend a laundry shower for Sharon Bradley near Hale Center in the home of Maurice Carson.

Joan Durbin attended the church service at Sunnyside on Sunday morning.

Clara Vick visited Saturday night

with Teeny Bowden and Andrea Hinojosa.

Bess Bills started chemo treatments Wednesday in Plainview and is doing better this time. She is still weak.

Anthony and Lori Sisemore and girls, Ezell and Verba Sadler and Lee and Louise Bradley attended the Christmas cantata at Springlake-Earth High School on Sunday night.

Sunday afternoon, a Christmas fellowship was held at the church honoring Anthony Sisemore and his family. He was back in the pulpit Sunday morning following his surgery.

Lyle and Rosie Louder and Lencie visited with Teeny Bowden and Joan Durbin on Sunday afternoon. Verba and Sharon Sadler visited earlier. Rosie and Lencie Louder visited in Amarillo with her mother Wednesday.

Dorothy Gilbreath entertained in her home Dec. 17 with the Gilbreath Christmas supper. Those present were Colby and Connie Gilbreath, Chauncey, Cailee and Carly; Matt and Ronda Gilbreath, Dustin and Tanner; Hal and Richelle Gilbreath, Cody and Colt; Peggy and Jimmy Curtis, Scott, Bridget and Samantha from Hobbs, N.M.

James Norrell shut down the Sunnyside Gin in the middle of last week after ginning a bountiful harvest.

### Reyes finishes basic training

Air Force Airman Rosemary Reyes has completed Air Force basic training at Lackland Air Force Base.

During the six weeks of training, the airman studied the Air Force mission, organization and customs and received special training in human relations.

In addition, airmen who complete basic training earn credits toward an associate degree through the Community College of the Air Force.

Reyes, daughter of Leo L. and Maria I. Reyes of Dimmitt, is a 1994 graduate of Dimmitt High School.

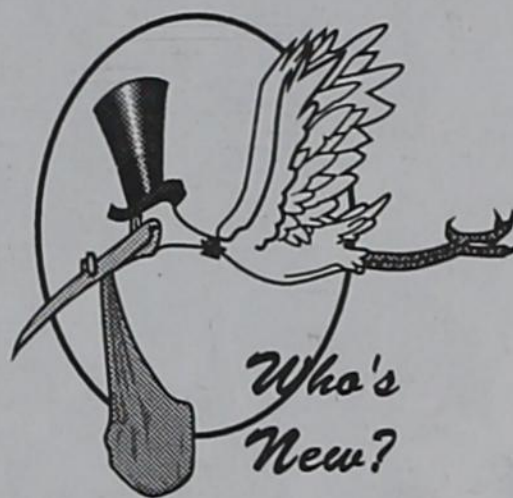

**PLAINS MEMORIAL HOSPITAL**  
Conrado and Arseli Saucedo are the parents of a boy, Gino Jared Saucedo, born Nov. 22 at Plains Memorial Hospital in Dimmitt. He weighed 7 lbs., 5 ozs., and was 20 inches long.

He has an older brother, Conrado Jr., and a sister, Dianey. His maternal grandparents are Julio and Lucia Gamez of Dimmitt. His paternal grandparents are Pedro and Sara Saucedo of Mexico.

Jaime Puente and Ramona Saucedo of Dimmitt are the parents of a daughter, Gabrielle Nicole Puente, born at 12:15 p.m. Dec. 13 at Plains Memorial Hospital in Dimmitt. She weighed 7 lbs., 8 ozs., and was 20 inches long.

She has an older sister, Persephanie Marie Puente, 13 months old. Paternal grandparents are Enrique and Janie Puente of Dimmitt. Maternal grandparents are Domingo and Victoria Saucedo of Dimmitt. Great-grandparents are Ramona Saucedo of Seminole and Gabino Puente of Sabin.

**OUT OF TOWN**  
Jeff and Suzan Collins Headrick of Phoenix are the parents of a daughter, Katy Elizabeth, born Dec. 9 at 11:09 p.m. at Phoenix Baptist Hospital. She weighed 6 lbs., 4 ozs., and was 20 inches long.

Maternal grandparents are Wayne and Darlene Collins of Dimmitt. Paternal grandparents are Robert and Vera Headrick of Sweetwater. Maternal great-grandmothers are Katy Collins and Gwen Patterson, both of Dimmitt.

**OUT-OF-TOWN**  
Daniel and Bobbi McGregor of Amarillo are the parents of a boy, Quinlin Keith, born Dec. 1 at Northwest Texas Hospital in Amarillo. He weighed 8 lbs., 13 ozs., and was 22 inches long.

His maternal grandparents are William and Catherine Hochstein of Nazareth. His paternal grandparents are Herb and Vondean McGregor of Amarillo. His great-grandparents include Florence and Lucille Schacher of Nazareth.

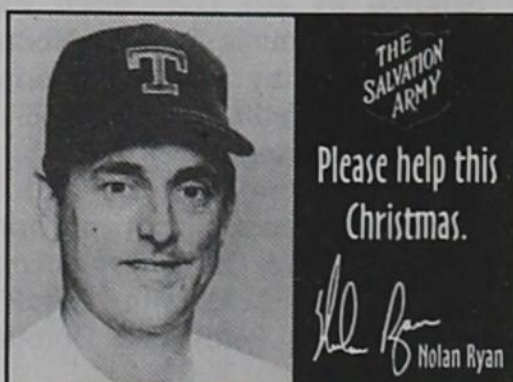

## STARLIGHT... SO RIGHT!

Send the FTD® Starlight™ Bouquet

This star-topped centerpiece makes a perfectly elegant gift for home or office!

Our Hands Move Hearts™

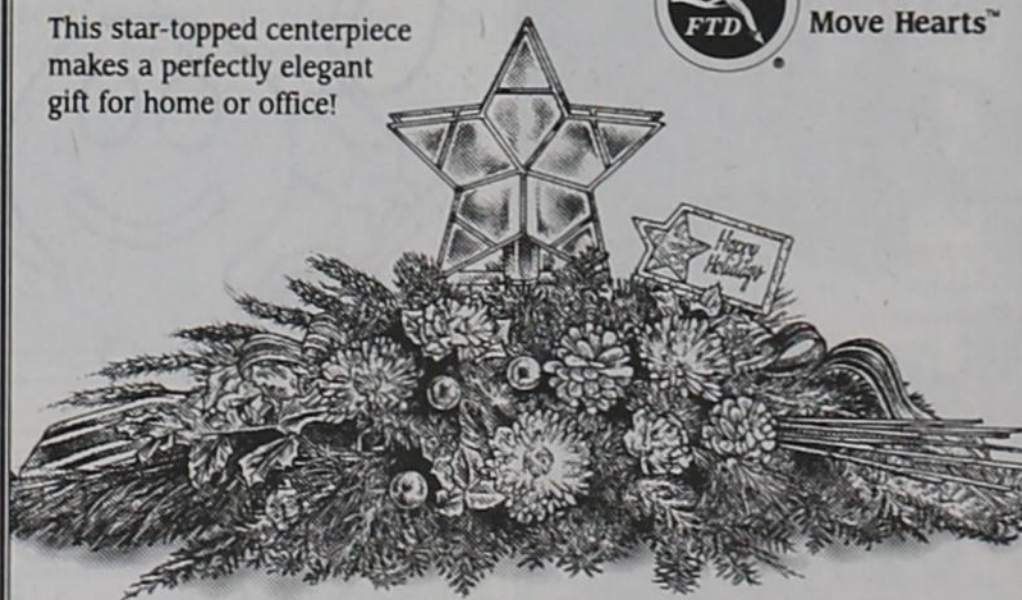

POINSETTIAS • UNIQUE GIFTS

Seale Florist

310 N. Broadway, Dimmitt

647-3554

© A Registered Trademark of Florists' Transworld Delivery Assn.™ A Trademark of Florists' Transworld Delivery Assn. © 1994 F.T.D.A.

## The beauty of Merle Norman holiday gifts.

Our affordably priced collection of elegant holiday gifts for Eyes, Lips and Nails will make everyone jolly this season. Come in today and experience the beautiful feeling at your nearest Merle Norman Cosmetic Studio.

**MERLE NORMAN** COSMETIC STUDIOS

The place for the beautiful face.™

TAMMY BLACK

647-5773  
115 E. Bedford, Dimmitt

\$18

\$15

\$18



## Nominations being taken for citizen honors

Nominations are being accepted for the Chamber of Commerce's *Citizen of the Year*, *Teacher of the Year* and *Citizen Through the Year* awards, which will be presented at the annual Chamber banquet. The banquet will be held Saturday, Jan. 21, 1995. Deadline for nominations is Jan. 13, 1995. Nomination forms may be picked up at the Chamber of Commerce office in Dimmitt.

## Two receive TSTC honors

Two county residents have received honors for the fall quarter at Texas State Technical College-Amarillo. Tom D. Cameron was named to the President's Honor Roll with a 4.0 grade point average for the fall quarter. Scott Heck was named to the Dean of Instruction's Honor Roll with a 3.5 or greater grade point average for the fall quarter.



**SCOUTS SORT STAPLES**—Members of Boy Scout Troop 266 in Dimmitt sort through hundreds of cans of food Monday to help prepare for the annual distribution of goods for the Brown Bag Project sponsored by the Castro County Ministerial Alliance. Food was collected at county churches the past three Sundays to give to county families in need on Wednesday. Also distributed were toys and other goods to county families. *Photo by John Brooks*



## Church Happenings

**First Baptist Church**  
First Baptist Church of Dimmitt will host a Christmas Eve service Saturday at 6 p.m. The service will feature an eye-witness monologue by a Bethlehem shepherd and a special candlelighting service. The public is invited to attend. The only Sunday activities will be a Christmas Day morning service at 10 a.m.

**Presbyterian Church**  
There will be a Christmas Eve candlelight service with carols and lessons at the Presbyterian Church and it will be open to the public Saturday at 7 p.m. There will be no Sunday School on Christmas Day, but there will be a Christmas Day worship service at 11 a.m. Steven Hoggard will preach

the sermon and Joan Craig will sing a Christmas lullaby written by her mother, Mrs. L.C. Braafladt.

### Dr. Milton Adams OPTOMETRIST

Office Hours:  
Monday-Friday, 8:30-5  
364-2255  
335 Miles, Hereford

### BAGGETT CHIROPRACTIC

Tuesday & Thursday  
10-1 and 2-6  
647-2664

M-W-F  
364-2222

**Shop Dimmitt first!**

Happy Birthday Happy Birthday Happy Birthday

**Becky Stovall**

turned

**40**

on Dec. 20th!

Happy Birthday  
Happy Birthday  
Happy Birthday

Happy Birthday  
Happy Birthday  
Happy Birthday

Happy Birthday Happy Birthday Happy Birthday Happy Birthday

## Social Security in Castro County

I read a sobering statistic the other day: a person dies every six minutes in the US as a result of an accident. And accidents are the leading cause of death among young men and women in the 25-44 age group.

These statistics represent real tragedies in life—the loss of a wife or husband, mother or father, son or daughter. Families grieve and try to pick up the pieces of their lives.

The personal grief is too often accompanied by considerations of how to replace the loss of income caused by the worker's death. Insurance helps in about two-thirds of the deaths of young workers, but only as a lump-sum payment and usually in a much smaller amount than many would suppose.

Social Security is a bulwark that most survivors can rely on, though. This fact is seldom thought of when people think about the Social Security program.

The Social Security taxes you pay also go toward providing survivors insurance. In fact, the value of the survivors insurance you have under Social Security is probably more than the value of your commercial life insurance.

When someone who has worked and paid into Social Security dies, survivor benefits can be paid to certain family members. These include widows, widowers (and divorced widows and widowers), children and dependent parents. Right now, 98 out of every 100 children could get benefits if a working parent should die. In fact, Social Security pays more benefits to children than any other federal program.

I know that many young workers in their early 20s haven't started their families yet. Some still live with their parents. In cases where a young worker provides one-half or more of the support for aged

parents (age 62 or over), if the young worker dies his or her parents may be eligible for Social Security survivors benefits based on the son's or daughter's work record.

For more information on Social

Security survivors benefits, call Social Security's toll free number—1-800-772-1213 — between 7 a.m. and 7 p.m. any business day. Our lines are busiest early in the week and early in the month, so it's best to call at other times.

## Church Directory

**New Hope Memorial Baptist**  
300 NE 7th, Dimmitt  
Rev. Claude Mullins

**Sunnyside Baptist**  
Sunnyside  
Anthony Sisemore.....647-5712

**First United Methodist Hart**  
Lillith Ardhuerumly.....938-2462

**La Asamblea Cristiana**  
400 NW 5th, Dimmitt  
Ruben Velasquez

**First United Methodist**  
110 SW 3rd, Dimmitt  
Johnny Robertson.....647-4106

**Iglesia De Cristo**  
E. Lee & SE 3rd, Dimmitt  
Pedro A. Gonzalez

**Immaculate Conception Catholic**  
1001 W. Halsell, Dimmitt  
Guillermo Morales.....647-4219

**Primera Iglesia Bautista Mexicana**  
301 NE 7th, Dimmitt  
Antonio Rocha.....647-4373

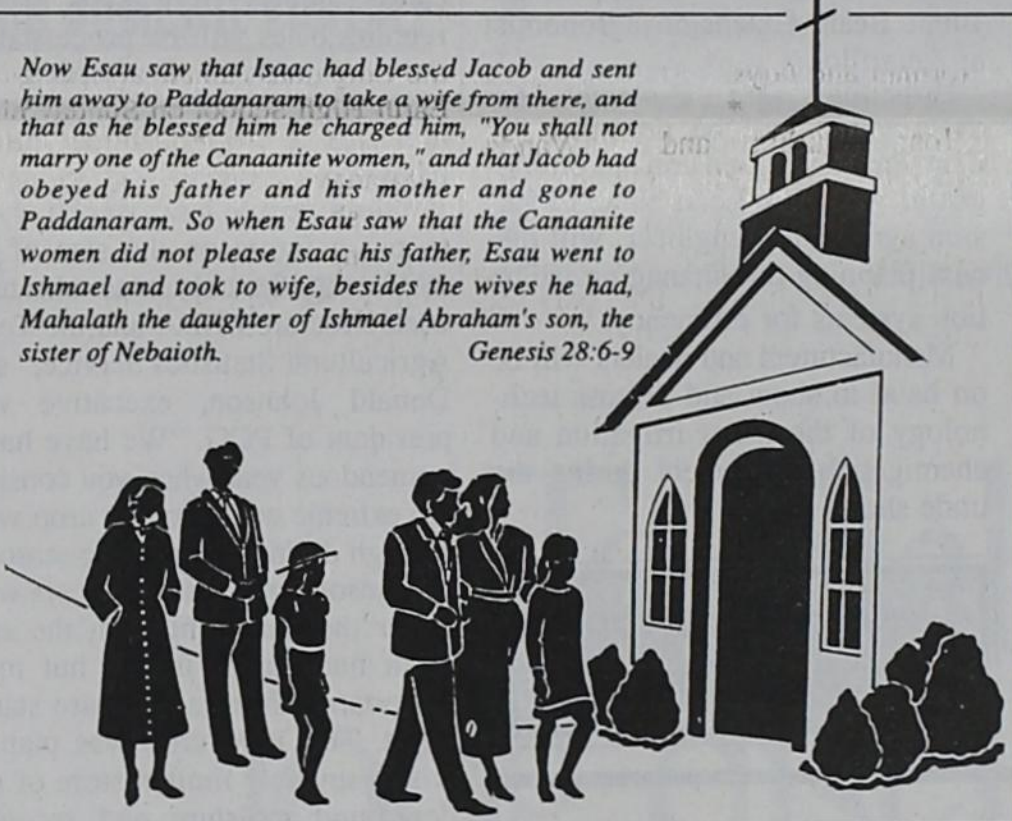

*Now Esau saw that Isaac had blessed Jacob and sent him away to Paddanaram, to take a wife from there, and that as he blessed him he charged him, "You shall not marry one of the Canaanite women," and that Jacob had obeyed his father and his mother and gone to Paddanaram. So when Esau saw that the Canaanite women did not please Isaac his father, Esau went to Ishmael and took to wife, besides the wives he had, Mahalath the daughter of Ishmael Abraham's son, the sister of Nebaioth.*  
Genesis 28:6-9

**Church of God of the First Born**  
611 E. Halsell, Dimmitt

**Immanuel Baptist**  
501 SE 3rd, Dimmitt

**Rosa De Saron**  
411 NE 6th, Dimmitt  
Maria Castaneda.....647-5598

**St. John's Catholic Hart**  
Guillermo Morales.....647-4219

**Church of Christ**  
SW 4th at Bedford, Dimmitt  
Harry Riggs.....647-4435

**Rose of Sharon Temple**  
407 NE 4th, Dimmitt

**First Baptist**  
302 Ave. G, Hart  
Gerald Aalbers.....938-2316

**Grace Fellowship**  
508 S. Broadway, Dimmitt  
Curtis Wood.....647-2801

**First Assembly of God**  
300 SE 2nd, Dimmitt  
Claude Hendricks.....647-5662

**First Baptist**  
1201 Western Circle Drive, Dimmitt  
Paul Kenley.....647-3115

**Lee Street Baptist**  
401 SW 2nd, Dimmitt  
Ronald Redding.....647-5474

**First Christian**  
600 Western Circle Drive, Dimmitt  
Jim Hardwick.....647-5478

**La Iglesia De Dios Del Promojenito**  
East Halsell Street, Dimmitt

**Presbyterian**  
1510 Western Circle Drive, Dimmitt  
Rev. Edward D. Freeman.....647-3214

**Holy Family Catholic**  
Nazareth  
Neal Dec.....945-2616

### This directory is sponsored by these businesses:

Compliments of:  
**Agri-Plex Transport**  
945-2225

**American Maize-Products Company**  
"Attend the Church of Your Choice"  
647-4141

Compliments of:  
**B & W Aerial Spray**  
N. Hwy. 385, Dimmitt • 647-2550

**C&S Battery & Electric**  
301 SE 2nd, Dimmitt  
647-3531

**Dale's Auto & Salvage**  
200 N. Hwy. 168, Nazareth  
945-2223

**Dimmitt Consumers**  
"Your Co-op Supplier"  
217 E. Bedford • 647-4134

**Dimmitt Equipment Co.**  
White Farm Equipment Irrigation Engines  
411 SE 2nd • 647-4197

**Dimmitt Medical Clinic**  
405 NW 3rd Street, Dimmitt  
647-5255

**Dimmitt Printing & Office Supply**  
200 E. Bedford • 647-3286

**Dimmitt Ready Mix**  
Commercial, Residential Concrete  
Backhoe & Ditching Service  
718 E. Bedford • 647-3171

**Farm Bureau Insurance**  
304 N. Broadway, Dimmitt  
647-5106

**Flagg Fertilizer Co.**  
Farm Chemicals  
Stark Bros. Trees & Shrubs  
Flagg Intersection • 647-2241

**Foskey Funeral Home**  
Mike Foskey, Jerrye Lilley, Tom McGill  
208 W. Halsell, Dimmitt • 647-5171

**Hart Producers Co-op Gin**  
Monty Phillips, Manger  
938-2189

**Higginbotham-Bartlett Co.**  
Lumber, Hardware, Housewares,  
Flooring, Garden Supplies  
109 N. Broadway, Dimmitt • 647-3161

**J&H Equipment Co.**  
Hwy. 385, Dimmitt  
647-3324

**La Coiffures**  
"Family Full Service Salon"  
118 S. Broadway, Dimmitt • 647-5501

**Lockhart Pharmacy**  
107 E. Bedford, Dimmitt  
647-3392

**Lowe's Pay & Save Foods**  
410 Broadway, Hart • 938-2312  
"Proud to Support the Community Churches"

**Sunnyside Farm Store**  
HCR 1, Box 69, Dimmitt  
647-2522

**Wright & Sons Produce**  
"Attend the Church of Your Choice"  
Dimmitt • 647-4361



**CONGRATULATIONS!** Plains Memorial Hospital Administrator Steve Goode (left) presents Santos Mireles with a certificate of appreciation and a check for \$200 last Thursday during an appreciation luncheon at the hospital. Mireles was named the hospital's "Employee of the Year" and the cash and certificate were part of her reward. She is a nurse's aide and works with the hospital's home health care division. *Photo by Anne Acker*

### December 1994

Sunday	Monday	Tuesday	Wednesday	Thursday	Friday	Saturday
<b>Troy's Sweet Shop</b>						
4	5	6	7	8	9	10
<b>will be OPEN</b>						
<b>Tuesday through Friday, Dec. 27-30</b>						
5:30 a.m. to noon						
<b>Closed Saturday, Dec. 24 through Monday, Dec. 26</b>						
<b>Closed Saturday, Dec. 31 through Monday, Jan. 2</b>						
25	26	27	28	29	30	31
116 W. Jones, Dimmitt			647-2645			



# ABI Agriculture Business Industry



## MINDING YOUR OWN BUSINESS



By DON TAYLOR

### A Christmas Story

The story of "Unlucky Jimmy" has become a Christmas tradition for this column. Because we have added thousands of new readers this year, I'd like to share it again.

Unlucky Jimmy is a sad little story my mother often read to me when I was small. It's about a little boy named Jimmy whose family was very poor. His little sister was an invalid and spent most of her days in bed. Christmas held no hope or joy for either of the children.

As he trudged home from school each day, Jimmy would stop to look at the toys in the bright store windows. More than anything, he wanted a little red fire engine. Jimmy knew he would never be lucky enough to get one. In fact, his only marble had rolled down a storm drain the previous week. He felt that he was the unluckiest

boy alive. He even called himself Unlucky Jimmy.

Then, one night just before Christmas, Jimmy received an invitation to a Christmas party for the poor children in the neighborhood. A nice lady from a nearby church mission promised Jimmy a special gift. Jimmy grew excited as he drew near the mission. He couldn't believe his eyes when he saw the Christmas tree. It was covered with lights and surrounded by toys. Jimmy saw a bright red fire engine just like the one in the store window.

When it came time for each child to pick out a gift, Jimmy's heart nearly stopped. He was afraid that someone else would pick the fire engine. Fortunately, when his turn came, the little truck was still under the tree. As Jimmy reached for the engine, he thought of his frail little sister at home in bed. He stopped and turned to the mission lady. He asked softly if he might pick two gifts, one for himself and one for his sister at home. The lady

shook her head sadly and told Jimmy there were only enough presents for one per child.

Jimmy looked longingly at the little fire engine. Then he picked out the prettiest doll under the tree. It had blue eyes and curly blond hair just like his little sister. As he returned to his seat with the doll, the other children began to laugh and make fun of him. Unlucky Jimmy clutched the little doll and ran from the mission. He stopped crying by the time he reached home.

Jimmy began to feel better when he saw the look of surprise and delight on his sister's face. As she hugged the doll and cried with joy, Jimmy didn't feel so unlucky after all.

Later, as Jimmy sat by his little sister's bed, someone knocked on the door. When he opened it, the mission lady was there. She gave him the red fire engine and explained to Jimmy that the children were sorry they had laughed at him. They had not known about his sick little sister. After she told them

why Jimmy had chosen the doll, the children asked her to bring the fire engine to Jimmy.

### The true meaning

I often think of Jimmy at Christmas time, usually when I'm feeling selfish. Would you join me this Christmas season in beginning a "Jimmy" tradition? We can make the coming year a joyous occasion for all people by giving of ourselves.

Volunteer time to your favorite church or charity. Make or bake something for someone less fortunate. Take time to listen to someone who needs you. Let's make this year a year of giving.

Remember the real reason we celebrate Christmas is Christ's birth. It is his life of giving, sharing and caring we should emulate.

Don Taylor is the co-author of *Up Against the Wall-Maris*. You may write to Don Taylor in care of *Minding Your Own Business*, PO Box 67, Amarillo, TX 79105.

## Growers to share success stories at irrigation meeting

Three area growers who possess the ability to succeed in irrigated farming will share their management techniques at the annual High Plains Irrigation Conference and trade show Jan. 5 at the Amarillo Civic Center.

Registration and the trade show begin at 8:25 a.m. and the conference program will begin at 9:25 a.m. Three continuing education units (CEUs) will be offered to those attending. A \$5 registration fee will include a catered lunch.

Harold Grall of Moore County, Rex McCloy of Hutchison County and Randy Hensley of O'Donnell will be the featured growers at the meeting.

Grall will discuss why and how he is using ridge till farming to

conserve and manage irrigation water and rainfall.

McCloy will share how he utilizes irrigation systems and current technology to cut crop production costs.

Hensley will discuss how he uses drip irrigation to boost cotton yields with limited irrigation water.

Freddie Lamm, a researcher at Colby, Kan., will present data on irrigating corn with drip irrigation and his view of the economic feasibility.

Other topics to be aired are the influence of 1994 weather on corn yields and the yield potential and economic comparison of short and full season corn and grain sorghum to match irrigation capacity. These will be discussed by Brad Lance, field agronomist with Pioneer Hi-Bred International at Lubbock, and Brent Bean, Extension agronomist at Amarillo.

Effective, safe strategies for chemigation will be presented by Carl Patrick, Extension entomologist at Amarillo. Leon New, Extension agricultural engineer, will discuss planning and managing irrigation systems for efficiency.

Manufacturers and dealers will be on hand to show and discuss technology of the latest irrigation and chemigation equipment during the trade show.

## Cotton Talks

Producers have finally made it to the "short-rows" in terms of the 1994 harvest season with many areas either close to or finished ginning.

The crop that just kept growing will likely top out very close to US Dept. of Agriculture's (USDA) December crop estimate, according to Plains Cotton Growers, Inc. of Lubbock. USDA puts upland cotton production in Texas crop reporting districts 1-N and 1-S at 3.03 million bales, a 100,000 bale increase from the 2.93 million bales projected since early September.

Backing up the three million bale figure are estimates from the Lubbock and Lamesa Classing offices which class the lion's share of the production in the 25-county area. A combination of these figures indicates samples from 2.88 million running bales will be processed by the two offices. Converting this figure to 480-pound statistical bales indicates a crop of three million bales.

"Since people have started trying to put a figure on the size of the 1994 crop, the only ones who have been close are USDA and the Texas Agricultural Statistics Service," said Donald Johnson, executive vice president of PCG. "We have had a tremendous year when you consider the extreme adversity the crop went through during the growing season."

Johnson notes that producers were under the gun right from the start on a number of fronts, but most importantly from a moisture standpoint. The 1994 crop was planted with a severely limited store of underground moisture and received little or no supplemental rainfall during the season to help bring the crop along.

Currently it is estimated that 95% of the area crop has been harvested and the remaining acreage will be off the stalk by Christmas. Ginning will also be mostly complete by Christmas, except for a few gins that will operate into the new year because they either have large backlogs or are located in areas that got started late.

So far the 1994 crop has continued the pattern of high quality across the board seen in last year's crop. Adverse weather during the harvest season that delayed some harvesting activity helped contribute to a slight fall in quality from 1993. So far the 1994 crop continues to have most bales fall into Color Grades 11, 21 and 31 (Good Mid-

dling, Strict Middling and Middling, respectively) and Leaf grades 2-4. All other quality factors have maintained very high levels on average throughout the season.

Wendell Wilbanks, director of the Lubbock Classing Office, estimates as much as 80 to 90% of the bales classed at his facility were stripped following the use of harvest aid chemicals. He notes that this has been a big contributor to the high quality exhibited by the crop.

Marketings continue to show a strong demand for High Plains cotton with some compresses reporting that as much as 40% of the crop has been shipped already. Prices also have been a pleasant surprise reversing their normal downward trend during the harvest period because of the increase in demand for West Texas cotton built on back-to-back years of high quality and outstanding delivery service by the area's warehouse industry.

## Compare Before You Buy Your Next Pivot System.

Zimmatic manufactures and sells more pivot systems than any other pivot company.

*The New World Leader!*  
Why?

*Unequaled Quality and Dependability*  
A Better Product At A Better Price

**Irrigation Pumps & Power, Inc.**  
West Highway 84, Muleshoe 272-5597

Call Wes Conway at 893-2540 or 272-5703 residence.

The offices of SWISHER ELECTRIC COOPERATIVE will be closed Friday, Dec. 23 and Monday, Dec. 26 for Christmas.

Emergency personnel will be on call at 995-3567 or 1-800-530-4344.

Happy Holidays from the Employees and Directors of Swisher Electric Cooperative!

Thank you for shopping Dimmitt!

TO ALL INTERESTED PERSONS AND PARTIES:

**SUNNYSIDE FEEDYARD** has made application with the Texas Natural Resource Conservation Commission for Air Quality Permit No. 26639 to expand a **Cattle Feedyard** in **Springlake, Castro County, Texas**. The location of the existing facility is **14 miles south of Dimmitt on State Highway 385**. Additional information concerning this application is contained in the public notice section of this newspaper. This notice is to be published on Dec. 15, 1994 and Dec. 22, 1994.

Hart Banking Center Offers You Competitive CD Rates

CD	APY
30 Day.....	5.15%
60 Day.....	5.20%
90 Day.....	5.39%
180 Day.....	5.86%
One Year.....	6.04%

For more information Call 938-2111.

The minimum balance to open an account and obtain the Annual Percentage Yield is \$50,000. APYs are offered on accounts opened from 12/20/94 through 12/26/94. A penalty may be imposed for early withdrawal.

**HCSB**  
**HALE COUNTY STATE BANK**  
Where Your Community Comes First  
Member E.D.I.C.

The 62nd Annual Meeting of the Stockholders of **Dimmitt Consumers** will be held at the **DIMMITT CITY HALL MEETING ROOM** Thursday, Dec. 22 at 7:30 p.m.

The purpose of the meeting is to hear the audit report, elect two directors, and transact any business that may come before the board. Door prizes will be awarded.

PLEASE TRY TO COME

**Dimmitt Consumers, Inc.**

Danny Rice, Manager

217 E. Bedford

647-4134

Happy Holidays!

Enjoy our Holiday Party!  
FRIDAY, 9 p.m. to midnight

Featuring the live music of Renegade!  
CASH BAR ONLY  
Members and Guests Welcome

Country Club of Dimmitt



# Birkenfeld to address soil convention Jan. 14

Bob Birkenfeld of Nazareth, a partner in KBG Composters, will sit on a panel which will discuss the ability of agriculture to protect and enhance our nation's soil and whether sustainable farming is possible in the region during the Southern Plains Conference.

The conference will be held Jan. 14 at the Amarillo Civic Center in the North Meeting Hall. The conference will begin with registration at 9 a.m. and will conclude at 4 p.m. Lunch will be catered by O.H.M.S. Restaurant, and the \$10 registration fee includes lunch. Registration should be made payable to Southern Plains Conference, and sent to P.O. Box 5644, Amarillo 79117-5644.

Theme for the conference is "Gift of Good Soil," and the meeting is being sponsored by the Promised Land Network in cooperation with Great Plains Composters Association and Arrowhead Mills, Inc.

An exploration of the history of soils in this region and the attempt to rediscover soil as a living organism with dynamic relationships that are not fully known will be featured during the conference.

Included will be presentations, an art exhibit and exhibition booths by a wide range of organizations.

"Soil is the matrix of all things living on the land," said Darryl Birkenfeld, organizer of the event. "Though it is a thin membrane covering the Earth's crust, all life

depends on it. With the wondrous accomplishments of modern agriculture, we tend to take soil for granted."

According to the Soil Conservation Service, three billion tons of precious topsoil are lost in this country each year to wind and water erosion.

Joining Bob Birkenfeld on the panel will be Peggy Prather Sechrist of Holistic Resource Management of Texas, Inc.; Dr. Bob Stewart of the West Texas A&M Institute of Dryland Agriculture; and John Husmann, Magnagro soil amendment representative.

Those people are working to fashion an agriculture that reverses the depletion of Southern Plains soils.

Among the speakers at the conference will be Jon Piper, a plant ecologist at the Land Institute in Salina, Kan., who will describe the 500 million year process that produced the soils first touched by farmers near the turn of this century. He will discuss modern agriculture's relationship with the soils. Piper, along with Judith D. Soule, has written a book, *Farming in Nature's Image*, earning a Ph.D. in botany from Washington State University. His research is geared toward developing a perennial agriculture that mimics the diversity and resilience of the Great Plains prairie.

Dr. P.I. Ittycheriah, in a presentation titled "Beyond N, P and K: The Essentials of Soil

Nutrition," will offer valuable information to gardeners and farmers, outlining the 13 elements soil must contain to provide healthy plant growth. Ittycheriah, who came to the US from India in the 1960s, holds Ph.D.s in chemistry and biology, farms in Curry County, N.M. and consults with dozens of West Texas and Eastern New Mexico farmers on soil nutrition.

Visual artists exhibiting works that convey a sense of soil's beauty and worth are Amy Winton, landscape painter and co-author of *Canyon Visions*; Gordon Darrow, landscape photographer; Trish Neusch, family farm photo documentary on "Our Life, Our Land, Our Future" and Dale Wilburforce, a wildlife photographer.

More than a dozen organizations and agencies are expected to provide information booths and exhibits.

## Cotton conference is planned Jan. 18

Cotton producers in Castro County can get a jump on the 1995 growing season by attending a conference on Jan. 18 at Olton.

The Jan. 18 conference is one of three regional meetings planned on the South Plains.

The first meeting will be held Jan. 16 in Lamesa and the second will be held Jan. 17-18 at Floydada.

Each meeting targets needs of growers in specific counties.

The Llano Estacado Conference will be held Jan. 18 at the Olton Ag Pavilion, located on US Highway 70 at Avenue D. The meeting will be tailored to concerns of growers in Lamb, Castro, Parmer and Bailey counties.

It will include updates on crop insurance reform by Dr. Jackie Smith, an Extension economist; worker protection standards by James Esty of TDA; farm bill update by Dr. Ed Smith; value-added cotton marketing by Bedford Forrest with TDA; a 1994 crop review by Dr. Kater Hake, Extension cotton specialist; 1995 pest outlook by Dr. James Lesser, Extension entomologist; and a boll weevil update from Roger Haldenby with Plains Cotton Growers.

The series opens with the Southern Mesa Cotton Conference at the Dawson County Annex Building in Lamesa. It will focus upon concerns for growers in Dawson, Borden, Gaines, Garza, Scurry, Terry and Yoakum counties.

The Caprock Cotton Conference will be Jan. 17-18 at the Plains Baptist Assembly seven miles south of Floydada on US Highway 62. It will address needs of growers in Crosby, Floyd, Hale, Briscoe and Lubbock counties.

"The conferences are a direct result of educational programming requested by producers," said Dr. Bob Robinson, Extension Service district director.

Robinson said the series of conferences was devised to allow more growers to take part and to fully address specific concerns in different growing regions of the South Plains.

Each conference will provide continuing education units which growers need to comply with state environmental regulations. Registration fees include meals and advance registration is desired. Growers may register with their county Extension office.

At each conference, Paulette Zakrzewski, legislative analyst and lobbyist for the National Cotton Council in Washington, D.C., will provide a legislative update and Adam Ballinger, publisher of *Fiber* magazine, will present an historical perspective on cotton production.

Mark Lange, director of economic services for the Cotton Council at Memphis, will describe the world cotton economic outlook and status of US farm bill deliberations at the Southern Mesa and Caprock programs. At both the Caprock and Llano Estacado programs, Nicholas Hahn, president of Cotton Incorporated in New York City, will report on its activities.

US Rep. Charles Stenholm (D-Texas) will provide a Congressional update at the Llano Estacado conference. Other featured speakers at the program will include Dr. Ed Smith of College Station, an Extension Service economist who will discuss present and future farm policy and Woody Anderson, chairman of the Texas Boll Weevil Foundation, who will talk on eradication efforts.



GLENN EHLY (LEFT) AND SCOTTY ABBOTT  
...Ehly won \$100 gift certificate at Amarillo show

Photo by John Brooks

## Ehly wins \$100 gift certificate

Glenn Ehly of Nazareth won a \$100 gift certificate at the Amarillo Farm Show recently.

Ehly registered at the booth occupied by Consolidated Farm Service Agency (formerly Agricultural Stabilization Conservation Service). The gift certificate was donated by West Texas Western Stores of Canyon and Amarillo, and Consolidated Farm Service Agency employees in the Texas Panhandle.

**FOR YOUR EYE SURGERY**  
CALL HERFORD REGIONAL MEDICAL CENTER

- Small Incision Outpatient Cataract Surgery
- Board Certified Eye Surgeon **Dr. Dik S. Cheung, M.D.**
- Accept Medicare, Medicaid Assignment

**FOR APPOINTMENT CALL 364-2141**

## Vegetable conference to focus on production and marketing

Strategies to assure profitable production and marketing of crops will share the spotlight with the latest information on safety and vegetable research during the annual High Plains Vegetable Conference in Hereford on Jan. 17.

Theme for this year's conference is "Opportunity Knocks." The meeting will begin at 8:30 a.m. at the Hereford Community Center, located at 100 Avenue C at Park Avenue. It is being sponsored by the Texas Agricultural Extension Service, High Plains Vegetable Growers and Shippers Council, Texas Agricultural Experiment Station, Texas Tech University, Deaf Smith County Extension Vegetable Development Committee, Deaf Smith County Chamber of Commerce and Texas Dept. of Agriculture (TDA).

The program has been approved by TDA for five continuing education units for restricted use and private pesticide applicators. Applicators are required to obtain five CEUs of training each year to retain certification. The \$25 registration fee includes lunch.

"The conference goal is to improve the competitive position of

Texas vegetables and to increase family farm profitability and sustainability," said Dr. Roland E. Roberts, Extension Service vegetable specialist at Lubbock who has coordinated the conferences since 1971.

"Speakers will present research-based information which will help growers and shippers enhance productivity, comply with laws and provide a safe working place for themselves and their workers," he said.

A special focus this year will be environmentally conservative practices which increase grower profits. Other sessions will stress worker protection standards for labor-intensive vegetable crops, how irrigation scheduling influences crop diseases, and current and pending legislation.

The luncheon will include a report from the South Plains Food Bank on its new Breedlove Dehydration Plant, which will go into full operation this spring and will process an estimated 20 million pounds of High Plains vegetables to supply food banks across Texas and the nation.

# Attention Farmers!

You need to comply with the new **WORKER PROTECTION STANDARD** regarding pesticide safety for you and your employees before Jan. 1. In order to help you comply, First United Bank has made available a video cassette that you and your employees may view at First United Bank. Upon completion of this tape, you will have completed your certification. You may view this tape at your convenience!

**FIRST UNITED BANK**  
DIMMITT-LUBBOCK-EARTH-SEAGRAVES

Call Joe Josselet today to reserve your time. Call 647-4151!

Member FDIC

**THERE'S NO EXCUSE FOR DOMESTIC VIOLENCE.**

For information on how you can help stop domestic violence, call us.

**1-800-777-1960**

Family Violence Prevention Fund

Happy Birthday Happy Birthday Happy Birthday

**Happy Birthday, Teresa!**

If you think turning 39 is funny, wait 'til you turn 40. It's hilarious.

Your friends

Happy Birthday Happy Birthday Happy Birthday

# To dial long distance within your area code, simply add your area code.

**1 + (your area code) + the number**

With so many new telephones, cellular phones, fax machines, modems and pagers, quite frankly, we need more phone numbers. So here's how GTE is freeing up a slew of new ones: Instead of dialing '1' plus a seven-digit number for long distance within your home area code, now simply dial '1' plus your area code, then the number. Easy, huh? Oh, and don't forget to reprogram any auto dialing equipment you may have. Speaking of auto dialers, GTE offers "Speed Calling-8," a time-saving feature that stores up to eight frequently called numbers. To order, call 1-800-346-4300. Then, whether you're dialing long distance or not, it's even easier.



It's amazing what we can do together.™



# Sports



## Nazareth, Dimmitt split Saturday doubleheader

Castro County basketball players, especially from Dimmitt and Nazareth, gather several dozen times during the year to play basketball.

Hence, it was no big deal Saturday when the Nazareth girls beat the Bobbies, 45-37, and the Dimmitt boys beat the Swifts, 62-55, at Kenneth Cleveland Gymnasium.

Yeah, right. "I am so tight right now," said Dimmitt girls coach Richard Wood, a veteran of about 600 basketball games.

Both teams came out tight in the girls game, which, like the boys contest, was played before a full house for the rare Saturday night encounter between the four county teams.

Dimmitt used a man-to-man defense most of the game, rare for the Bobbies. They used the matchup defense to help contain Melinda Schmucker, and Amy Ethridge played her most of the night. Schmucker had just 11 points, but still led the Swiftettes' balanced attack. Carie Wethington and Kelley Boyd each had seven points, while K'Lynn Gerber, Amy Pohlmeier and Jill Ramaekers each had four points.

Kim Thomas had 20 of Dimmitt's 37 points. The Dimmitt girls, hampered by Nazareth's tough man defense and problems shooting the ball, hit just 16 of 59 shots, 32%. The Bobbies had a slow start, hitting just one of 10 field goal tries in the first quarter, and never really recovered.

The Bobbies made four free throws in the first 3:16 of the game for a 6-5 lead, but Nazareth took the lead for good on a basket by Schmucker with 1:53 to go in the first period. Schmucker hit a trey with 1:02 left, then Ramaekers made a basket with eight seconds left to give the Swiftettes a 12-6 advantage at the end of the period.

Dimmitt got within two early in the third quarter on a basket by Kim Thomas to make it 22-20, but that was as close as the Bobbies got in the second half. Dimmitt also made just one more free throw in the game after the first quarter, and the Bobbies never shot a one-and-one in the second half.

Dimmitt scored two straight baskets in the middle of the second quarter, one by Ethridge off a Thomas steal, and another by Thomas to make it 16-14 with 3:25 to play in the first half. Gerber nailed a trey with 3:01 left to end

that rally, and the teams traded baskets the rest of the half. Naz led 22-18 at the break.

Each team missed its first three shots of the second half before Thomas found the hoop with 5:28 to go in the third to make it 22-20. Nazareth ran its lead from two to eight points with a three-pointer by Carie Wethington from the top of the key with 1:08 to go in the third for a 31-23 lead. Kara Josselet scored with 45 seconds to go in the quarter to make it 31-25 after 24 minutes.

Both teams missed their first two shots before Schmucker hit a shake-and-bake layup with 6:50 to play to re-establish an eight-point advantage. Dimmitt cut it to three, 38-35, with 3:11 to go on a basket by Thomas. Naz regained a seven-point lead in the next 40 seconds when Denia Durbin got behind the defense for a basket with 3:01 to go, and Ramaekers nailed two free throws with 2:31 to play for a 42-35 lead.

Dimmitt had a slight lead on rebounds, 29-25. Nazareth had 16 turnovers and Dimmitt had just 12.

In the boys game, Brandon Smith converted a three-point play with 5:01 to go in the second quarter for a 26-23 Dimmitt lead, and the Bobcats held on the rest of the way for the seven-point lead.

An error in the third quarter credited the Swifts with three extra points, but the mistake didn't make a difference in the game's outcome, other than making the official score three points closer than the actual score. Scott Brockman was the recipient of the "extra" three pointer.

Brockman had 17 to lead the Swifts.

Derrick Thomas led all scorers with 18 points. The Bobcats had remarkably balanced scoring: Justin Newman, Joey Martinez and Chad Ellis each scored eight points; Smith and Joe Larra both had seven points; and Fernando Ontiveros had six points.

Thomas, in just his third game of the year and coming off playing 37 minutes against Tulia the night before, just missed a triple- or quadruple-double. He had eight rebounds, eight steals and eight assists to go with his 18 points. He had just one mistake and committed only two fouls.

"When Derrick plays and plays well, the whole team plays well," Dimmitt coach Alan Steinle said. "I thought our kids played awful well, especially coming off the game against Tulia the night before. They played good defense all night and just got after it real well."

The Swifts were obviously missing Gaylon Schilling, who injured his hand two weeks ago and may be out for a while longer.

Dimmitt got its record to .500 (7-7) for the first time this year thanks to making 10-of-12 field goals in the second period. The hot shooting Bobcats went from a 19-17 deficit after a basket by Robby Schmucker with 7:42 to go in the first half to a 13-point lead, 36-23, on a Thomas trey with 3:02 to go in the quarter. The Bobcats had a 40-31 lead at halftime.

The Bobcats posted their biggest lead of the night on a trey by Martinez to make it 47-35 with 3:44 to go in the third quarter. The Swifts, officially, got within five at 51-46 with 5:55 to go in the game, but Ontiveros hit back to back baskets to give Dimmitt a nine point margin, and the Bobcats weren't pressed the rest of the game.

Dimmitt teams also won the JV games, with the JV Bobcats downing the JV Swifts 84-61. The JV Swiftettes fell to the JV Bobbies, 50-36.

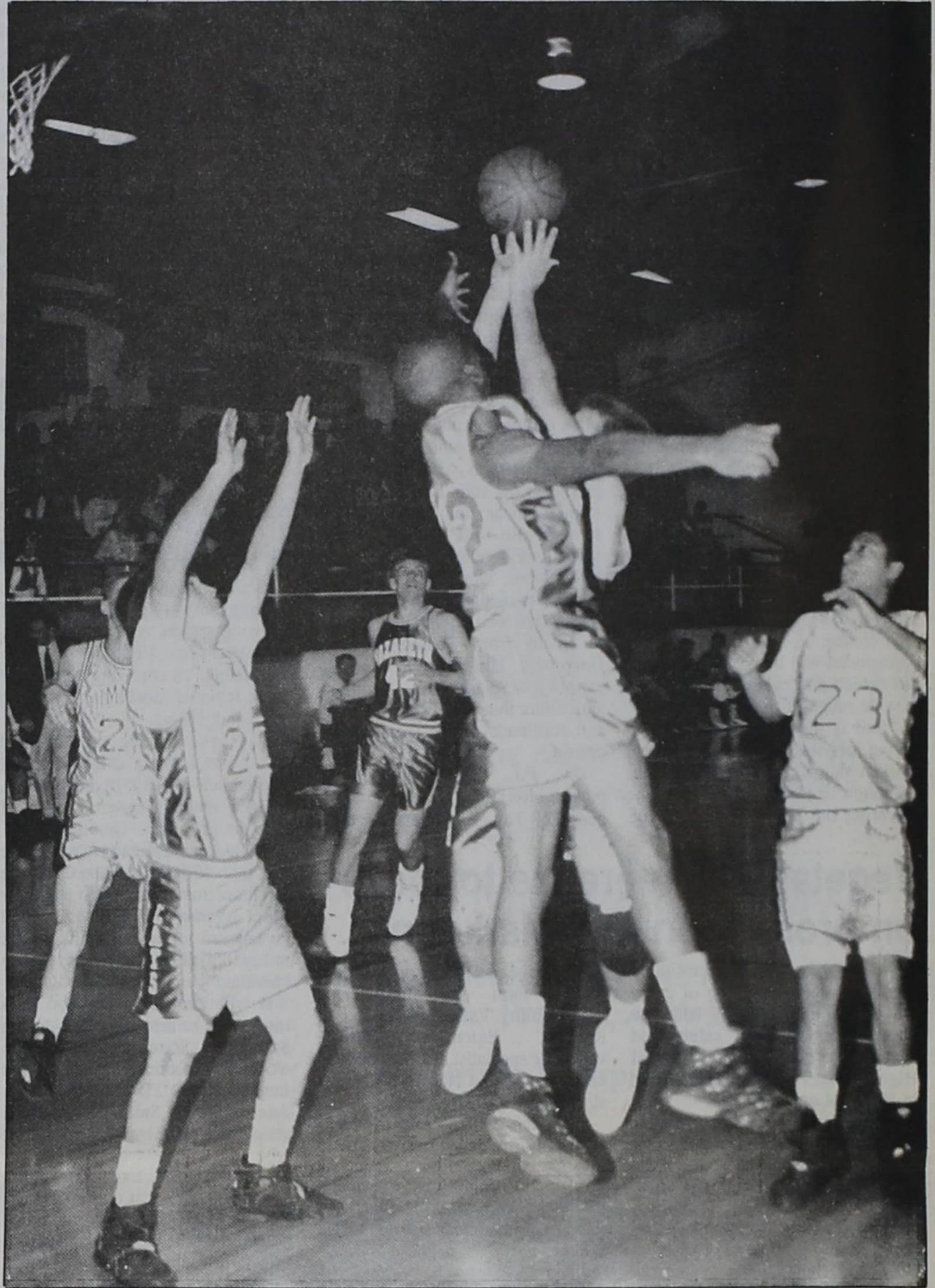

DIMMITT'S BRANDON SMITH (12) gets in front of Nazareth's Scott Brockman and foils Brockman's scoring hopes during first-half action Saturday in Dimmitt. Smith gets help from teammates Justin Newman (24), Joe Larra (20) and Joey Martinez (23) on the play. Also pictured is Nazareth's Coby Schacher (42). The Bobcats controlled the tempo throughout most of the second half and reached the .500 mark on the season with a 62-55 win over the Swifts.

Photo by Anne Ackler



IN POSITION for a rebound is Nazareth's Kelley Boyd (42), who nabs the carom over Dimmitt's Tiffany Wilcox and Amy Ethridge while teammate Amy Pohlmeier (34) gets in position for the outlet pass during action Saturday night between the county rivals. The Swiftettes won the close battle, 45-37. Boyd and Wilcox each had seven points in the game. Dimmitt's Kim Thomas was the leading scorer with 20 points and Nazareth's top individual was Melinda Schmucker with 11.

Photo by Anne Ackler

### KDHN "Your Sports Station"

#### CATCH THESE LIVE SPORTSCASTS!

- Daily, M-F:  
 7:05 a.m. .... Texas State Network Sports  
 12:25 p.m. .... Texas Sports Page with Ray Stone  
 4:50 p.m. .... Dallas Cowboys Report
- Thursday:  
 9 p.m. .... Dallas Mavericks vs. Seattle
- Friday:  
 9 p.m. .... Dallas Mavericks vs. Portland
- Monday:  
 8 p.m. .... Dallas Mavericks vs. Phoenix
- Tuesday:  
 7:30 p.m. .... Dallas Mavericks vs. Phoenix

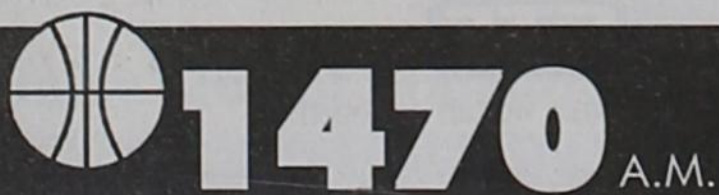

#### Together We Can

The Crucial Shoppes  
 Hereford Travel Center

This week we have  
 4,898 CRUISES FOR SALE

DISCOUNTS  
 Available on Most Cruises

806-364-6813 800-225-0190  
 119 East 4th Street, Suite 2  
 Hereford, TX

## Good Luck, Longhorns

### in the SUNDOWN TOURNAMENT

Monday, Tuesday and Wednesday



KIM GROSSMAN, Sr. W

## Good Luck, Ladyhorns

### in the LITTLEFIELD TOURNAMENT

Tuesday, Wednesday and Thursday

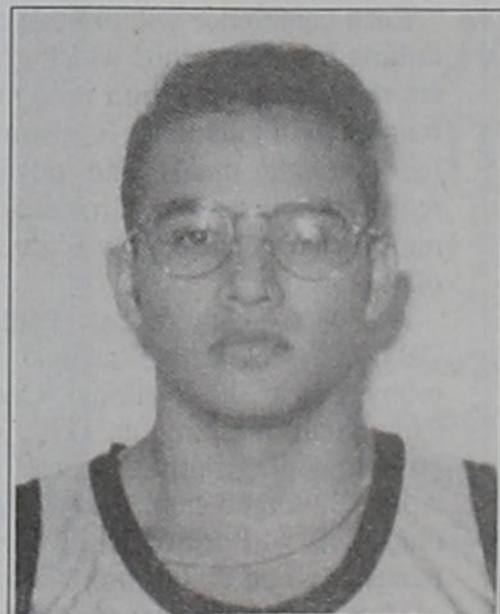

ERASMO CASTILLO, Sr. G

WE'RE ALL PROUD OF OUR LONGHORNS!

- Bennett Grain & Fertilizer  
 Cargill Grain Division  
 Castro County News  
 Dimmitt Agri Industries, Inc.  
 Dimmitt IGA/Thriftway  
 First United Bank  
 Kittrell Electronics  
 Pay & Save Foods  
 Schaeffer, Sutton & Schaeffer, C.P.A.  
 Wilbur-Ellis Tide Division  
 Whit's End Flowers & Gifts





# Hoop it up!

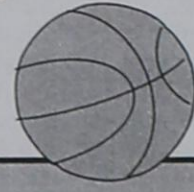

## Good Luck, Bobbies and Bobcats

in the  
**Lubbock Caprock Holiday Tournament**  
Thursday, Friday and Saturday (Dec. 29, 30 and 31)



### GIRLS' BRACKET

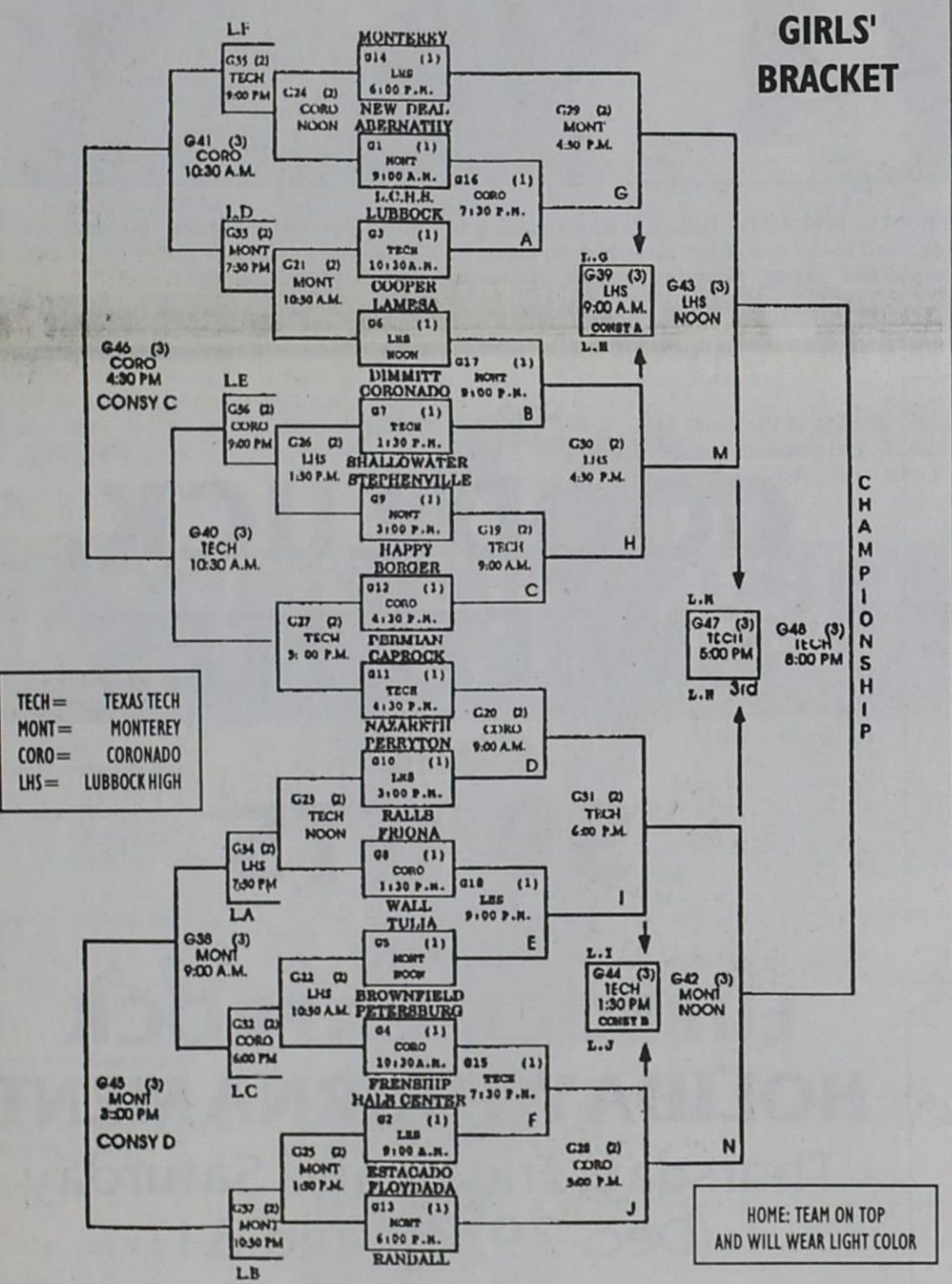

### BOYS' BRACKET

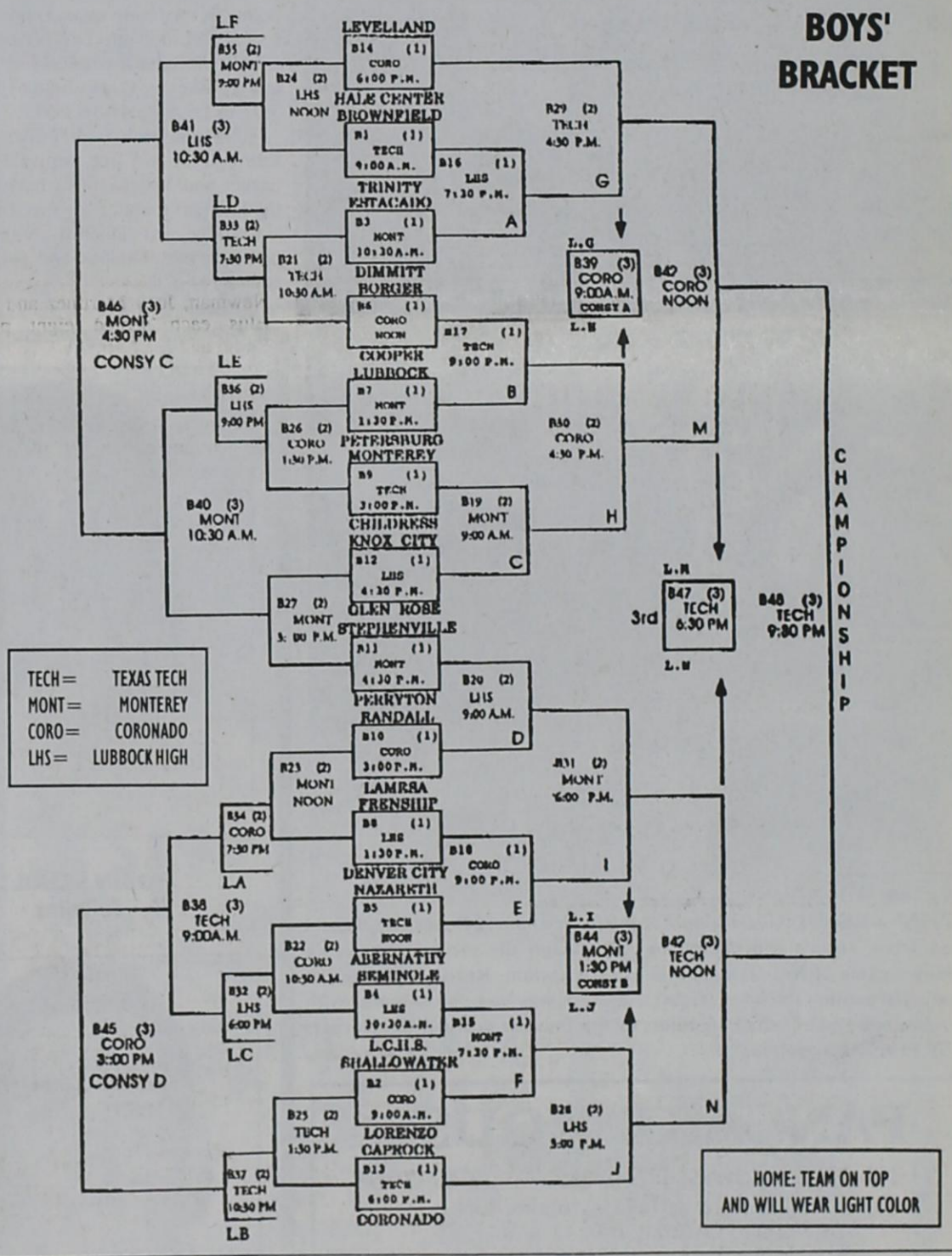

*Support the merchants who support our athletic teams!*

- |  |   |   |  |
|--|---|---|--|
| <ul style="list-style-type: none"> <li>American Maize-Products Co.</li> <li>B&amp;W Aerial Spray</li> <li>C&amp;S Battery &amp; Electric</li> <li>Canterbury Villa</li> <li>Castro Co-op Gin, Inc.</li> <li>Castro Oil &amp; Gas, Inc.</li> <li>Circle M Irrigation</li> <li>Dimmitt Agri Industries, Inc.</li> <li>Dimmitt Consumers</li> <li>Dimmitt Equipment/NAPA</li> <li>Dimmitt Feed Yards</li> <li>Dimmitt Printing &amp; Office Supply</li> </ul> | <ul style="list-style-type: none"> <li>Dimmitt Ready Mix</li> <li>Don's Wrecker Service &amp; Body Shop</li> <li>El Sombrero Restaurant</li> <li>Farm Bureau Insurance</li> <li>First United Bank</li> <li>Flagg Fertilizer Co.</li> <li>Gary's Engine &amp; Machine</li> <li>George's Exxon Station</li> <li>George Real Estate</li> <li>Dr. Gary R. Hardee &amp; Staff</li> <li>Don Hargrove, Contractor</li> <li>The Headhunter</li> </ul> | <ul style="list-style-type: none"> <li>Hereford Texas Federal Credit Union</li> <li>Higginbotham-Bartlett Co.</li> <li>Hi-Plains Oil Co.</li> <li>J&amp;H Equipment Co.</li> <li>E.M. Jones Ditching</li> <li>Jones-Rawlings Insurance Agency</li> <li>K-Bob's Steak House</li> <li>Kittrell Electronics</li> <li>Lockhart Pharmacy</li> <li>Look Cattle Feeders</li> <li>Dr. B.D. Murphy &amp; Staff</li> <li>Nelson Well Service</li> </ul> | <ul style="list-style-type: none"> <li>The North Gin of Dimmitt, Inc.</li> <li>Paxton Tire &amp; Service</li> <li>Pro-Ag, Inc.</li> <li>Schaeffer, Sutton &amp; Schaeffer</li> <li>Stanford's Body Works</li> <li>Terra International</li> <li>Dimmitt IGA/Thriftway</li> <li>Tidwell Spraying Service</li> <li>Dr. Morris Webb</li> <li>Westex Federal Land Bank Association</li> <li>Westway Trading Corp.</li> <li>Wright &amp; Sons Produce</li> </ul> |
|--|---|---|--|



# Bobcats outlast Hornets in triple overtime thriller

Dimmitt coach Alan Steinle has been blessed with a deep bench this year.

If you had told him before Friday's game against Tulia at Kenneth Cleveland Gymnasium that he would be playing at the end of the contest with Joey Martinez, Joe Larra, Chad Ellis and Fernando Ontiveros on the bench, he would have thought he was either kicking the Hornets or getting kicked.

"Boy, I never would have dreamed it," Steinle said after his Bobcats escaped with a 74-70 win over Tulia.

The Dimmitt girls also won, a 55-46 over the tough Lady Hornets.

"Hey, that was a great win for our team," Steinle said. "We had some kids who were exposed to some pressure and that's going to be good for them and for us in the long run. That's a game I would have hated to lose, and I'm glad we didn't."

"We lost, but that game still helped us a lot," said Tulia coach Tommy Miller. "We have a very young team and a game like that is going to help us on down the line. We had a bunch of sophomores out there at the end, and we played pretty well and had a few chances to win it."

The boys game was marred by fouls and slowed by constant free-throw shooting. Dimmitt had 27 fouls, Tulia 32; Dimmitt made 29 of 44 free throws, while Tulia made 17 of 30.

Zach Bell hit the only field goal by Dimmitt in 12 minutes of overtime, but the Bobcats hit five of eight free throws in the third overtime to finally turn off the lights.

Tulia led early in the game with four treys and jumped to a 16-8 lead, but Dimmitt had four treys in the first quarter, too, and came back to take the lead on a Brandon Smith free throw with 1:20 left in the first period, 19-18. Tulia never led the rest of the way, and bounded back from a 31-21 deficit in the second quarter to 35-31 at halftime. The Hornets didn't score a field goal in the first 5:52 of the second quarter until Tim Marshall scored off an offensive rebound to make it 31-24.

Dimmitt went on a 10-2 run early in the third quarter for a 50-38 lead before Tulia stormed back to 50-46 late in the period. Dimmitt led by seven at the end of three, and was up 55-46 after a Chad Ellis basket early in the fourth quarter.

Tulia outscored the Bobcats 14-5 in a 2:30 stretch in the fourth quarter to tie the score at 60 with 3:20 to play. Dimmitt had a pair of three-point leads in the last two minutes, but Tulia fought back to tie it at 65 on a three-pointer with 27 seconds left.

The Bobcats missed two front ends on one-and-one chances in the last minute that could have won the game.

In the first overtime, both teams had chances to win it from the free throw line, but Dimmitt missed the front end twice and Tulia once on one-and-one opportunities.

Bell and Tulia's Tim Marshall had the only two points in the second overtime. In the third four-minute extra period, Thomas hit both ends of a two-shot foul with 2:48 to play, then Omar Rascon hit the front end of a one-and-one 10 seconds later for a 72-69 Bobcat advantage. Rascon hit both ends of a one-and-one with 18 seconds to play for the final four-point margin.

Thomas led Dimmitt with 19 points. Newman had 15, Larra 14 and Smith 12 for the Bobcats.

The Dimmitt girls apparently lulled the Tulia girls into thinking it was going to be an off night for the Bobbies as the Lady Hornets ran to a six-point lead in the first quarter and led by three at halftime, 28-25.

Dimmitt had rebounded from the six point disadvantage to claim a 19-17 lead on a pair of free throws by Dolores Dimas with 4:15 to go in the first half and 21-18 on a Tiffany Wilcox basket with 3:18 to play. Tulia came back with three straight steals and eight points for a 26-21 lead in the next two minutes.

In the third, Dimmitt came back to finally tie the score at 34, then cashed in a trey by Amy Ethridge, two free throws by Wilcox and a basket by Kim Thomas for a 41-34 lead at the end of three. The score might have been more, but neither team scored in the last 2:12 of the period.

The Bobbies ran their lead to 11 points in the fourth quarter, once on a steal and snowbird by Thomas for a 45-34 advantage with 6:43 to play and a basket by Carrie Bradley with 5:01 to go for a 47-36 lead.

Tulia got back within five, but Ethridge hit two free throws and a basket and Wilcox hit a basket in the last two minutes for the win.

Ethridge led Dimmitt with 14 points, while Thomas and Wilcox added 11.



THOMAS FOR TWO—Dimmitt's Kim Thomas gets open and scores two of her game-high 20 points in second-half action Saturday against Nazareth.

Swiftettes defending on the play are Melinda Schmucker (12) and Kelley Boyd (42). Nazareth went on to win the game, 45-37.

Photo by Anne Acker



RIPPIN' A REBOUND—Dimmitt's Justin Newman (24) tears a rebound away from Tulia's Tim Marshall (40) during the second quarter of Friday's game at Kenneth Cleveland Gymnasium. Ready for an outlet pass is Fernando Ontiveros (right). Newman was high for Dimmitt with 13 rebounds and also had 15 points as the Bobcats downed the Hornets 74-70 in triple overtime.

Photo by John Brooks

**PANCAKE HOUSE**  
 313-A N. Broadway, Dimmitt 647-2065  
 Open Sunday through Friday 6 a.m. to 1 p.m.  
 Open Saturday 6 to 11 a.m.  
 Luncheon Special Served Daily  
 Breakfast Special Weekly  
 Meeting Room Available (Capacity 16)  
 Take-Out Plates • Free Delivery  
 Closed Dec. 24, 25, 26, 31 and Jan. 1

**Sands Motel**  
**DIMMITT'S BEST VALUE MOTEL**  
 Newly Remodeled • Ample Parking  
 Direct-Dial, Touch-Tone Phones  
 Free Local Calls  
 647-3178 or 647-2345



ROBIN SCHULTE  
 Jr. Point

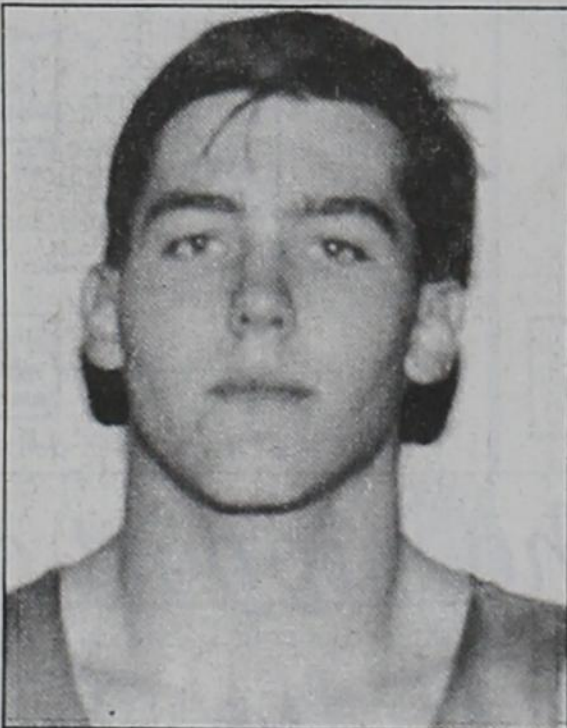

JARET SCHULTE  
 Sr. Post

**GOOD LUCK,  
 SWIFTETTES**  
 and  
**SWIFTS**  
 in the  
**LUBBOCK CAPROCK  
 HOLIDAY TOURNAMENT**  
 Thursday, Friday and Saturday  
 (Dec. 29, 30 and 31)

**FIRST GAME: SWIFTS vs. ABERNATHY,**  
 Thursday, Dec. 29, 12 noon at Texas Tech

**FIRST GAME: SWIFTETTES vs. CAPROCK,**  
 Thursday, Dec. 29, 4:30 p.m. at Texas Tech

NAZARETH, TEXAS ★ HOME OF CHAMPIONS!

American Maize-Products Co.  
 Kent Birkenfeld Seed Co.  
 Castro County News  
 Dale's Auto & Salvage  
 Deaf Smith Electric Cooperative  
 Dimmitt Agri Industries, Inc.  
 Dimmitt IGA/Thriftway  
 First United Bank  
 Gerber Welding  
 Higginbotham-Bartlett Co.

Kern Supply  
 Dr. B.D. Murphy & Staff  
 Nazareth Booster Club  
 George Nelson Trucking, Inc.  
 The 19th Hole  
 Oasis Package Store  
 Pro-Ag, Inc.  
 Schaeffer, Sutton & Schaeffer  
 Terra International  
 Westex Federal Land Bank



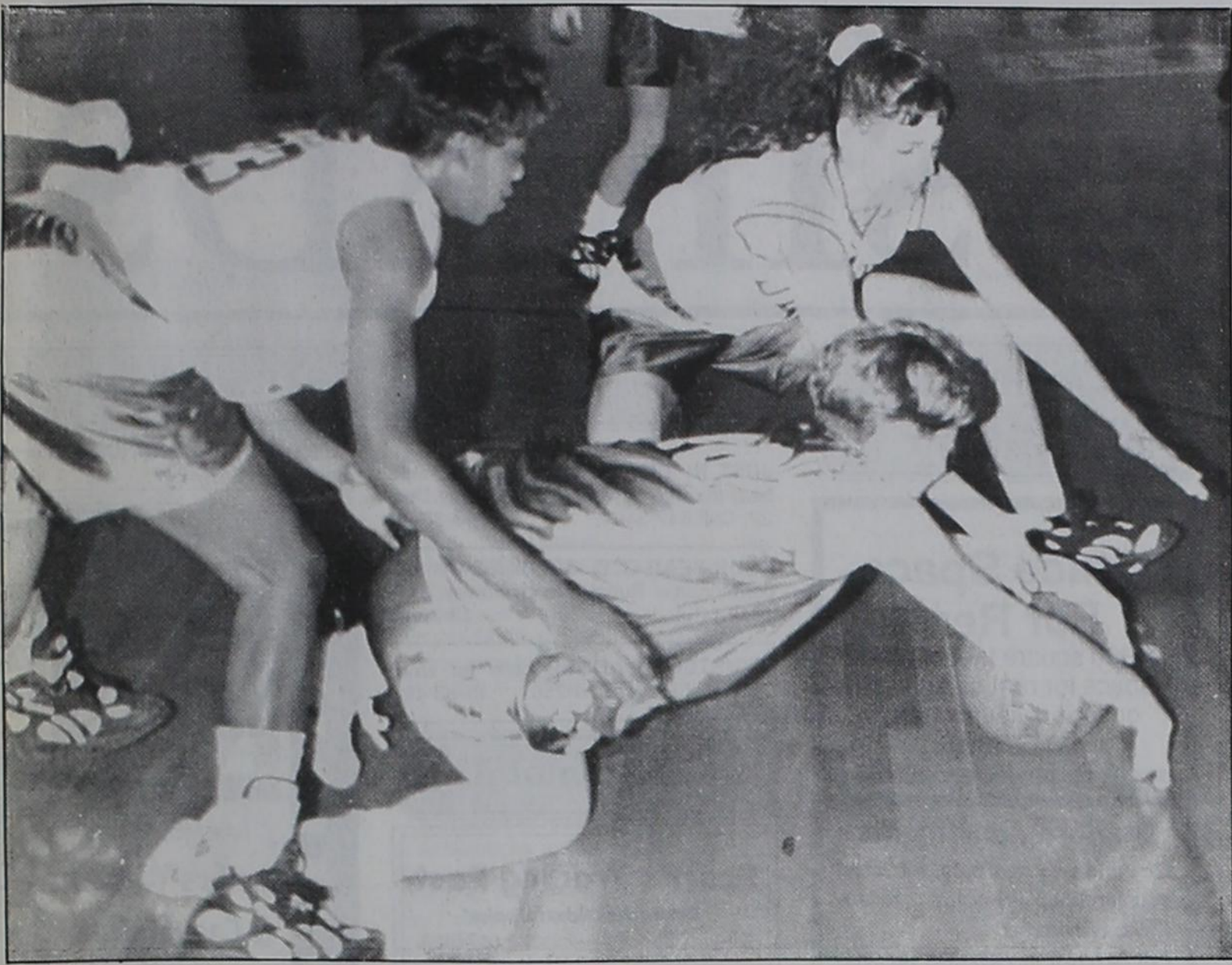

**LOOSE BALL SCRAMBLE**—Nazareth's Jill Ramaekers dives after a loose ball as Dimmitt's Kim Thomas and Carrie Bradley rush in from behind. Ramaekers can't get a handle on the ball, but neither can Thomas or Bradley and it rolls out

of bounds, off of Ramaekers' fingertips and Dimmitt gets possession. The two teams met in a regular season game Saturday evening in Dimmitt with the Swiftettes winning, 45-37. *Photo by Anne Acker*

# Naz splits contests at Vega, Levelland

Nazareth survived a potentially bad situation Friday and rallied to beat the Vega Longhorns 68-65 Friday at Vega.

In the early game, the Swiftettes had a six-point lead slip away in the last two minutes of regulation, then fell in overtime, 45-44.

Nazareth had come back from a 33-all tie at halftime in the boys' game to lead after three quarters, 49-46. The game was a one-point affair in the fourth quarter when the scoreboard was accidentally disconnected by children playing under the stands.

Words were exchanged after the scoreboard was fixed, according to Nazareth fans, but the game continued and the Swifts stayed off the Longhorns in the final period. Swifts fans said Vega fans apologized for the incident after the game.

Scott Brockman and Colby

Pohlmeier each scored 17 for the Swifts.

In the girls' contest, Nazareth led by 38-32 late in the fourth quarter when the Vega girls came back to tie the score at 38 at the end of regulation. In the overtime, Vega scored late again for the one-point win.

Melinda Schmucker led the Swiftettes with 25 points, while Amy Pohlmeier added 7.

Tuesday, the Swiftettes ran into a buzzsaw at Levelland as the Lady Lobos dumped the Naz girls, 32-14. Nazareth made every shot attempted in the first quarter. Problem was, they were able to get just one shot against the Levelland defense as the Lady Lobos took a 12-2 lead.

By halftime the Swiftettes had eight points, but Levelland scored another nine for a 21-8 lead.

Nazareth scored just three points

in each of the last two quarters as Levelland, the No. 1 team in Class 4A, scored just 11 for the low-scoring win.

Schmucker had eight points and Pohlmeier four for the Nazareth girls.

In the boys' game, the Swifts overcame a slow start to take a 56-51 win over the Lobo JV.

Levelland led 11-9 after one quarter, but the Swifts turned the tables on Levelland in the second period for a 20-16 lead at the half.

Both teams revved up their offense in the third quarter as the Swifts took a 41-34 lead after three. Nazareth had three players in double figures: Pohlmeier with 15, Brockman with 14 and Coby Schacher with 11.

Both teams will be off until Dec. 29, when they open play in the Caprock ABC Holiday Tournament in Lubbock.

# Lee explodes for 42 as 'Horns rout Lions

J.R. Lee exploded for 42 points Friday as the Hart Longhorns rebounded from a district-opening

loss to Springlake-Earth for a 90-68 pasting at New Deal.

The Hart girls ran their district record to 2-0 with a 75-49 rout of the Lady Lions in the early game Friday.

## Bobbies bounce Lady Harvesters

Christmas is coming just at the wrong time for the Dimmitt Bobbies, who won their sixth game in their last eight Tuesday with a 65-48 win at Pampa.

The Bobbies put a suffocating defense on the Lady Harvesters, and ran away to a 19-2 lead at the end of the first quarter. At halftime, the Bobbies led 31-14 over the Class 4A squad. Dimmitt extended its lead to 22 points, 52-30, after three periods.

Kim Thomas led Dimmitt with 17 points, while Halley Bradley added 12.

Pampa returned the defensive favor in the boys' game, holding the Bobcats to just five points in the second quarter to cruise to a 75-50 win.

Pampa led by just one, 20-19, after one quarter, but the Harvesters outscored Dimmitt 15-5 in the second stanza for a 35-24 halftime lead.

Pampa outscored Dimmitt by 13, 27-14, in the third quarter for a 62-38 lead.

Justin Newman led Dimmitt with 10 points. Joey Martinez added 8.

Both Dimmitt teams are off until the Caprock ABC Holiday Tournament Dec. 29-31 in Lubbock.

Lee's explosion was aided by 14 points from Mano Valderaz and 12 points by Raynea Garcia. Hart led by 10, 23-13, at the end of the first quarter. The Longhorns extended their lead to 16, 42-26, at halftime.

Hart's lead was sliced to nine, 60-51, after three, but the 'Horns came on in the fourth quarter for a 22-point win.

In the girls' contest, it was no contest as Brandi Key had her most productive night of the year, scoring 21 points to lead the Lady 'Horns to the 26-point win.

Hart led by 13, 22-9, by the end of the first quarter. The Lady 'Horns ran their lead to 16 at the half, 36-20, and led by 24 after three periods, 57-33.

Traci Knox had 12 points and Shea Bennett had 10 for the Lady 'Horns, 2-0 in district.

Monday, Hart took a break from district play with a pair of wins against Lazbuddie at the HHS gym.

The girls won big, 77-29, with four players in double figures, while the 'Horns dumped Lazbuddie, 82-60.

Shea Bennett had 19, Sandra Lopez had 18, Trinette Finch 12 and Jodi Card 10 for the Hart girls. They led 21-8 at the end of the first quarter and by 16 at the half, 32-16. The Lady 'Horns jumped out big in

the second half, outscoring Lazbuddie 45-13 over the last two quarters.

In the boys' matchup, five Longhorns were in double figures in the 22-point win. Lee had 22 points, Valderaz and Garcia 14, Jeremy Card 11 and Dusty Ortiz 10.

Hart led by six, 21-15, after one period and 40-29 at halftime. Hart outscored Lazbuddie by 10 in the third quarter to extend the lead to 66-45 after the period.

Hart teams will be in tournaments next week after taking the mandatory five days off for the holidays. The Lady 'Horns will be in the Littlefield Tournament while the boys will play in the Sundown tournament.

Both teams get back into District 3-AA action Jan. 3 when they host Hale Center. League-leading Abernathy will host Hart on Jan. 6.

## Correction

In last week's cutline information with a photograph of a man injured in an accident at the Burlington Northern crossing on SH 86 in Dimmitt, the *News* reported the man had been treated and released from Plains Memorial Hospital, then was re-hospitalized later for treatment of injuries. That information was obtained from a telephone call to the hospital.

Linda Rasor, director of nursing at PMH, told the *News* Monday that the man was not released but was transferred to another hospital.

The *News* regrets the error.

# SCOREBOARD

**FRIDAY**  
Bobcats 74, Tulla 70 (3OT)  
Tulia— 20 11 15 19 2 2 1—70  
Dimmitt—21 14 18 12 2 2 5—74  
Dimmitt: Derrick Thomas 19, Justin Newman 15, Joe Larra 14, Brandon Smith 12.

Bobbies 55, Tulla 46  
Tulia— 14 14 6 12— 46  
Dimmitt—8 17 16 14— 55  
Dimmitt: Amy Ethridge 14, Kim Thomas 11, Tiffany Wilcox 11.

Longhorns 90, New Deal 68  
Hart— 23 19 18 30— 90  
New Deal—13 13 25 17— 68  
Hart: J.R. Lee, 42, Mano Valderaz 14, Raynea Garcia 12.

New Deal 49, JV Longhorns 42  
Lady 'Horns 75, New Deal 49  
Hart— 22 14 21 18— 75  
New Deal—9 11 13 16— 49  
Hart: Brandi Key 21, Traci Knox 12, Shea Bennett 10.

JV Lady 'Horns 36, New Deal 16  
Vega 45, Swiftettes 44 (OT)  
Naz— 9 9 10 10 6— 44  
Vega— 7 11 12 8 7— 45  
Nazareth: Melinda Schmucker 25, Amy Pohlmeier 7.

Vega 28, JV Swiftettes 23  
Swifts 68, Vega 65  
Naz— 18 15 16 19— 68  
Vega— 16 17 13 19— 65  
Nazareth: Scott Brockman 17, Colby Pohlmeier 17.

JV Swifts 60, Vega 41  
**SATURDAY**  
Swiftettes 45, Bobbies 37  
Nazareth— 12 10 9 14— 45  
Dimmitt— 6 12 7 12— 37  
Nazareth: Melinda Schmucker 11, Kelley Boyd 7, Dimmitt: Kim Thomas 20, Tiffany Wilcox 7.  
JV Bobbies 50, JV Swiftettes 36

Bobcats 62, Swifts 55  
Nazareth— 16 15 14 10— 55  
Dimmitt— 17 23 9 13— 62  
Nazareth: Scott Brockman 21, Robby Schmucker 9, Dimmitt: Derrick Thomas 18, Justin Newman 8, Joey Martinez 8, Chad Ellis 8.  
JV Bobcats 84, JV Swifts 61

**MONDAY**  
Lady 'Horns 77, Lazbuddie 29  
Lazbuddie— 8 8 8 5— 29  
Hart— 21 11 25 20— 77  
Hart—Shea Bennett 19, Sandra Lopez 18, Trinette Finch 12, Jodi Card 10.  
JV Lady 'Horns 40, Lazbuddie 21

Longhorns 82, Lazbuddie 60  
Lazbuddie— 15 14 16 15— 60  
Hart— 21 19 26 16— 82  
Hart—J.R. Lee 22, Mano Valderaz 14, Raynea Garcia 14, Jeremy Card 11, Dusty Ortiz 10.

JV Longhorns 60, Lazbuddie 52  
Levelland 32, Swiftettes 14  
Nazareth— 2 6 3 3— 14  
Levelland— 12 9 4 7— 32  
Nazareth: Melinda Schmucker 8, Amy Pohlmeier 4.

Levelland 51, JV Swiftettes 14  
Swifts 56, Levelland JV 51  
Nazareth— 9 11 21 15— 56  
Levelland—11 5 18 17— 51  
Nazareth: Colby Pohlmeier 15, Scott Brockman 14, Coby Schacher 11.

Levelland Sophs 53, JV Swifts 46  
Bobbies 65, Pampa 48  
Dimmitt— 19 12 21 13— 65  
Pampa— 2 12 16 18— 48  
Dimmitt: Kim Thomas 17, Carrie Bradley 12.

Pampa 56, JV Bobbies 45  
Pampa 75, Bobcats 50  
Dimmitt— 19 5 14 12— 50  
Pampa— 20 15 27 13— 75  
Dimmitt: Justin Newman 10, Joey Martinez 8.  
Pampa 68, JV Bobcats 65

**TO ALL OUR FRIENDS & CUSTOMERS...**  
"We Wish You a Merry Christmas and the Best for the New Year!"  
Your Allsup's Employees

**ALLSUP'S**  
PRICES EFFECTIVE THROUGH DECEMBER 24, 1994  
DIMMITT

**Christmas Trees**  
AS LOW AS \$10<sup>99</sup>  
• New Mexico Mountain Trees 'Fir, Balsam & White Fir'  
• Northern Michigan 'Scotch Pine'

SAVE ON COCA-COLA 12 OZ. CAN, 6 PK. \$1<sup>99</sup>

ALLSUP'S BREAKFAST BURRITOS FOR ONLY 99¢

SAUSAGE EGG & CHEESE OR HAM, EGG & CHEESE

ALLSUP'S CORN DOG FOR ONLY 79¢

60% FREE CONTACT COLD MEDICINE 12 HOUR CAPLETS \$4<sup>59</sup>

WILSON'S TURKEY BREAST & COOKED HAM 4" X 6" 10 OZ. PKG. \$1<sup>99</sup>

CORN KING CHOPPED HAM 4" X 6" 10 OZ. PKG. \$1<sup>29</sup>

30 MED. OR 20 LG. SHURFINE DIAPERS PKG. \$4<sup>49</sup>

NEW AJAX LAUNDRY DETERGENT 32 OZ. BOX \$1<sup>29</sup>

BRAWNY PAPER TOWELS JUMBO ROLL 99¢

REG. OR THINS DORITOS® TORTILLA CHIPS ALL VARIETIES \$2.09 SIZE \$1<sup>49</sup>

ALLSUP'S SANDWICH BREAD 1.5 LB. LOAF 60¢ EACH OR 2 FOR \$1

SAVE ON GOLD MEDAL FLOUR 5 LB. BAG 99¢

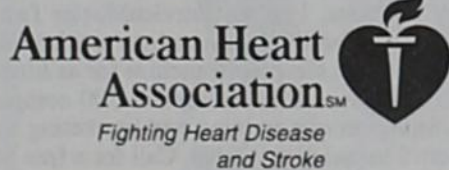

# DON'T GIVE MONEY TO STRANGERS

Trust your heart: The American Heart Association. Since 1924 we've sponsored lifesaving education programs and funded more than \$1.2 billion in research. Other organizations may copy us, but they can't hold a candle to our heart and torch. To learn more, call 1-800-AHA-USA1.



Call before noon Tuesday to place your classified ad:

647-3123



**WHAT IT COSTS:**

If you pay cash, the first time your ad runs it will cost you at least \$3 (20 cents a word with a \$3 minimum). Every consecutive time after that you run your ad with NO CHANGES in the ad, it is 15 cents a word with no minimum. If you want us to bill you, the first time your ad runs it will cost you at least \$5 (20 cents a word with a \$5 minimum). Every consecutive time after that that you run your ad with NO CHANGES in the ad, it is 15 cents a word with no minimum.

**Where to find ads**

- Homes and land for sale.
- Farms for sale
- Homes and apartments for rent.
- Things people want to rent.
- Miscellaneous items for rent.
- Miscellaneous items for sale.
- Garage sales.
- Household goods for sale.
- Farm equipment and supplies.
- Agricultural services.
- Feed, seed and grain for sale.
- Farm produce for sale.
- Livestock and pets.
- Automobiles for sale.
- Recreational vehicles.
- Auto parts and supplies.
- Business opportunities.
- Services.
- Students seeking work.
- Help wanted.
- Miscellaneous wanted.
- Notices.
- Lost and found items.
- Cards of thanks.
- Legal notices.

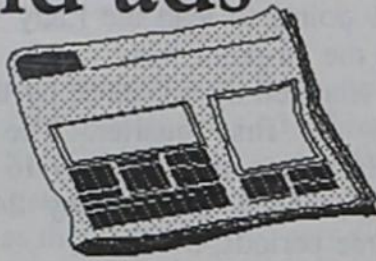

**Make your own ad!**

You CAN write your own classified! Just put down the essentials, what you think people will be interested in. You can count the words and send a check with your ad to PO Box 67, Dimmitt 79027, or bring it by 108 W. Bedford. (The cost is up there in the box with the dollar sign). Here's an example of an ad, and how to count words: Classified advertising for sale. Big bargains for advertisers. 647-3123, 108 W. Bedford. That ad has 12 words. Phone numbers are one word. Addresses are usually three words. If it's paid in cash, it's \$3 the first week and \$1.80 for each week after that. Now, you can write your ad:

Name: \_\_\_\_\_  
 Address: \_\_\_\_\_  
 City \_\_\_\_\_ State \_\_\_\_\_ Zip: \_\_\_\_\_  
 Daytime phone number: \_\_\_\_\_

**Publisher's notice**

All real estate advertised in this newspaper is subject to the Fair Housing Act of 1968 which makes it illegal to advertise "any preference, limitation or discrimination based on race, color, religion, sex or national origin, or any intention to make any such preference, limitation or discrimination. This newspaper will not knowingly accept any advertising for real estate which is in violation of the law. Our readers are informed that the dwellings advertised in the newspaper are available on an equal opportunity basis.

**1-Real Estate, Homes and Land**

Excellent location—1616 Sunset Circle. Completely re-decorated, three bedrooms, 2-1/2 baths, office, central heat/air, double garage with openers, storage shed, lots of extras, great neighborhood. Call Mike at 647-4151 or 647-3601 (leave message) for appointment.

**1-Real Estate, Homes and Land**

FOR SALE: 3-2-2 house located near school. Possible owner finance. Call 817-379-0016. 1-36-5tc

1995 OAKWOOD, 3 bedroom, 2 bath for as little as \$1,080 down and \$267 per month. Buy in December and enjoy no payment till March! Only 2 left at this price! Call Scott today at 1-800-372-1491. 1-36-3tc

DOUBLE WIDES! Too many to list! 1994 model close-out. Prices already reduced thousands! Enjoy no payments till March with home purchased in December! Discount for cash buyers! No reasonable offer refused. 14 to choose from! Call Scott for an appointment to save a bundle! 1-800-372-1491. 1-36-3tc

**3-Real Estate For Rent**

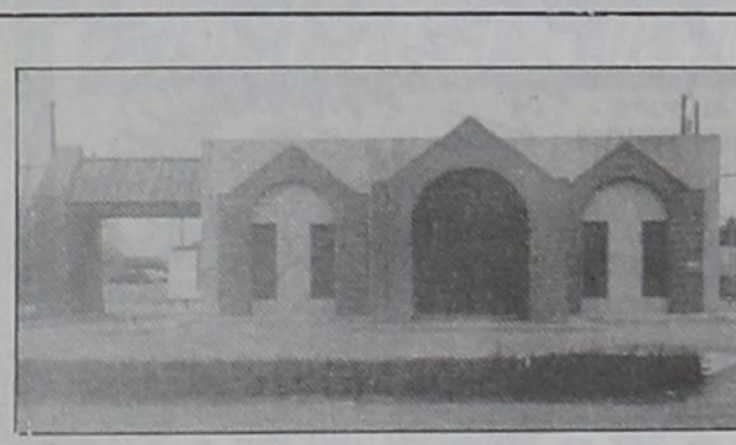

**CRAMPED FOR ROOM?**  
 We have LOTS of room for you! Two offices, reception area and plenty of parking! Call us today for all the details!  
**647-4652**

**3-Real Estate For Rent**

**CLASSIFIEDS**

**1-Real Estate, Homes and Land**

**DON'T BE A RENT SLAVE.** Very nice three bedroom stucco. \$35,000.

**LOCATION, CHARM AND VALUE.** Three bedrooms, 1-3/4 baths, built-ins, storage and more for only \$57,000.

**HEREFORD MILLER BUILDING.**

**THE TIME TO BUY IS NOW.** Three bedrooms, 1-1/2 baths, two living areas, built-ins. In good shape with a good price. \$48,000.

**SUPREME LIVING** in this well built home. Everything you could want from sunroom and double fireplace to guest quarters. \$225,000.

**PRICED RIGHT** for quick sale in Hart. Three large bedrooms with 1-3/4 baths, two car garage and storm cellar in good location. \$42,000.

**SENSIBLY PRICED**, this three bedroom is located on three lots. In good shape both inside and out. New listing at \$25,000.

**INEXPENSIVE—NOT CHEAP.** Three bedroom with lovely basement, large extra room and great patio. \$35,000.

**CHOICE LOCATION ON CORNER LOT.** This three bedroom, 2-1/2 bath is for you. Brick fireplace, sunny kitchen, basement, sunroom and more. Owner ready.

**FARM DRastically REDUCED.** 360 acres joining city limits. Four irrigation wells, one sprinkler. Extra clean.

**GEORGE REAL ESTATE**  
 S. Hwy 385 647-4174

Jimmie R. George, Broker  
 647-3274

Mary Lou Schmucker.....945-2679  
 Reta Welch.....647-5647

**HOUSE FOR SALE BY OWNER:** Carpenter's dream! 3 bedroom brick house, double-car garage, wood deck, large shop on large lot outside the city limits. Other amenities. Fire damaged, but structurally sound. Call 647-2655 after 5 p.m. 1-34-4tc

**SALE**

16x80 stock reduction. Must reduce all inventory NOW! Payments \$256\* monthly. Down payment \$1250.\*\* Buy now and save. FREE DELIVERY AND SETUP. FREE SKIRTING.

**BELL MOBILE HOMES**  
 806-894-7212

\*10% Dn \*5% Dn \*\*12% Dn/APR 240 months

**HOUSE FOR SALE:** 2 bedroom, 1 bath, 1-car garage, located at 205 SW 3rd. For more information contact Hubert Edwards at 647-4244 or Darla Rice in Canyon at 806/655-4304. 1-26-1tc

**\*DOUBLEWIDES\***

Many to choose from. Must reduce inventory. Buy now for best price. Payments \$265 monthly. FREE DELIVERY AND SETUP. FREE SKIRTING.

**BELL MOBILE HOMES**  
 806-894-7212

10% Dn \*12% APR 240 months

**2-Farms For Sale**

Please call & talk to me about a pre-con yard with nice 3 bed, 2 bath home & the chance to rent 4 choice quarters; and 276 acres of choice land for sale south of Dimmitt.

**SCOTT LAND CO.**  
 Ben G. Scott, 647-4375 day or night

**3-Real Estate For Rent**

**DIMMITT SENIOR CITIZENS APARTMENTS**  
 622 N.W. 5th  
 ONE AND TWO BEDROOM APARTMENTS FOR RENT  
 Call 647-2638  
 S&S Properties Equal Opportunity Housing

**3-Real Estate For Rent**

**Office Space For Rent**  
 1,900 square feet of office space for rent as one unit or six individual offices.  
 647-5384

**Stafford Apartments**  
 One and two bedroom, furnished or unfurnished. Privacy yard, microwave, dishwasher.  
 Call 647-2631 or 647-3696 evenings

FOR RENT: Three-bedroom house. 505/763-1944. 3-33-1tc

**4-Want to Rent**

WANTED! Three bedroom, two bath house to lease or lease purchase in Dimmitt. 806/764-3528. 4-37-4tc

**5-For Rent, Misc.**

**RENT TO OWN**  
 NEW TV'S, VCR'S & APPLIANCES  
 No credit checks.  
**KITRELL ELECTRONICS**  
 647-2197 Dimmitt

STORAGE SPACES for rent. Call 647-3447 or 647-2577. 5-1-1tc

**6-For Sale, Misc.**

MAGIC DIET! Leave your fat behind. Ask me how. 1-800-636-6999. 6-35-12tc

**SANI WAX** cleaners and polishes. Recommended by cabinetmakers for all furniture finishes, including Formica. Available at Higginbotham-Bartlett Co., 109 N. Broadway, 647-3161. 6-26-1tc

IF YOUR CARPET is stain resistant, then you need HOST, the Dry Extraction Carpet Cleaning System. Don't void your carpet's warranty with improper cleaning. Some methods can actually destroy your carpet's protective coating. But the makers of StainMaster, Wear-Dated and Worry-Free carpet say the HOST System won't void their warranties. HOST was rated #1 by a leading consumer magazine. Available at Higginbotham-Bartlett Co., 109 N. Broadway, Dimmitt, 647-3161. 6-27-1tc

CONKLIN products for sale. Robert Duke, 647-5517. 6-30-1tc

**Trash & Treasures**  
 143 N. Main, Hereford

Use our financing or lay-a-way for great deals on elegant metal or wood furniture.  
 364-8022 or 1-800-647-8022

**9-Farm Equipment**

FOR SALE: 16' King offset disc; 24' 485 IHC tandem disc; 28' Hamby sweep plow; 14' IHC drill d.t. 806/276-5678. 9-24-1tc

**10-Agricultural Services**

CUSTOM SWATHING and hay baling. Custom livestock hauling. Tommy Kellar, 647-4614 or 647-2712 (mobile). 10-27-1tc

WILHELM CUSTOM FARMING. Lavern, 945-2518; Henry, 647-5425. Subsoil and conventional plowing. 10-51-1tc

CUSTOM SWATHING and baling. Call Roy Schilling, 647-2401. 10-36-1tc

ROUND BALE HAULING. Donald Shelton, 647-3558; 647-7568, mobile. 10-31-1tc

**BUY IT. SELL IT. FIND IT.**  
**CLASSIFIED**

**13-Livestock, Pets**

JUST IN TIME for Christmas, a child's best friend, puppies. Will be ready Dec. 22. Call 647-3491. 13-36-2tc

FOUR-YEAR-OLD GELDING with papers for sale. Puppies to give away. 647-4674. 13-35-1tc

REGISTERED ANGUS bulls for sale. Call 647-5220 or 938-2561. 13-33-4tc

**14-Automobiles**

**Scott's Trading Post**  
 Dimmitt's Oldest Dealer  
 S. Hwy. 385 647-3414

1992 CHEV. SILVERADO 4X4  
 1/2 Ton, loaded, white

1989 GMC SLE 1/2 TON  
 Loaded, 43,000 miles, real cream puff

1988 OLDSMOBILE 98  
 4-door, white, loaded

1991 CHEV. DIESEL SILVERADO  
 4x4, loaded, 53,000 miles

1981 BUICK LESABRE LIMITED CPE.  
 One owner, 54,000 miles

**Our everyday prices are lower than their sale prices!**

For a QUICK QUOTE CALL  
**STEVENS CHEVY-OLDS**  
 Hereford, Texas  
 1-800-299-CHEV

**15-Recreational Vehicles**

MOTORCYCLE for sale. Tour bike. \$9,000. 647-5120. 15-35-3tp

**16-Automotive Parts & Supplies**

BARGAIN! Camper top for short-wide pickup. 647-3286. 16-35-4tp

**18A-Insurance**

NEED CAR INSURANCE? Low payments. 806/647-4247. 6-46-1tc

**18-Services**

**KIS**  
 1-hour photo service  
**Sheffy's Western & Casual Wear**  
 119 SE 2nd, Dimmitt

ALCOHOLICS ANONYMOUS, 647-2577. 18-34-5tc

**Dimmitt Ready Mix & Construction**  
 Commercial & Residential  
 ■ Septic Systems  
 ■ Plumbing  
 Licensed, Bonded and Insured  
 Call 647-3171

**George's Exxon EXON FULL SERVICE**  
 Oil Changes  
 Car Washes  
 647-4641  
 George Lopez 402 N. Broadway

WANT TO LOSE WEIGHT? Or feel better? 30 days, \$30. Call 647-2242. 18-40-1tc

**Texas SCAN**  
 Statewide Classified Advertising Network

More than 300 Texas newspapers for \$250. Call this newspaper for details.

COMPLICATIONS FROM NORPLANT implants or breast lactation drug, Parlodel, or failed back fusion (Pedicule Screws)? Call 1-800-833-9121, free legal consultation. Carl Waldman, Board Certified Personal Injury Trial Lawyer.

NORPLANT: FREE LEGAL consultation. 1-800-933-9121. Carl Waldman, Board Certified Personal Injury Trial Lawyer.

BIRTH CONTROL IMPLANT health problems? Norplant? Call 1-800-833-9121. Free legal consultation. Carl Waldman, Board Certified Personal Injury Trial Law, helping injured Texans since 1957.

SERIOUS CHILDBIRTH INJURY? Child impacted in birth canal? Dystocia? Call 1-800-833-9121. Free legal consultation. Carl Waldman, since 1957, Board Certified Personal Injury Trial Law Texas.

GM TRUCK FIRES, Bronco II, Jeep, ATV, Minivan & pickup rollovers. Serious injuries & death. Free consultation 1-800-883-9858 David P. Willis, Houston, Texas \*\*\*\* Board Certified Personal Injury Trial Lawyer.

CAREER INFORMATION: COMPLETE information guide/workbook for postal & government jobs. Includes sample exam & applications. Scott Career Systems, 1-800-489-1170, 24hrs.

CLEANING FRANCHISE, BUILD a family business. Let the ServiceMaster family help your family start your own residential or commercial cleaning franchise for as little as \$5,955 down. Fortune service 500 company offering unique training and marketing support. Financing available. Call for a free brochure: 1-800-230-2360.

HAPPY JACK FLEABEAACON: latest technology in home flea control without chemicals. Works night & day on dog & cat fleas. Distributed by WALCO International 1-800-234-1375.

136.81 ACRES, WEST of Del Rio. West Texas brush, hills, canyons. Beautiful view of mountains of Mexico. Rio Grande River access. \$1,700 down, \$166/month (10%-15 yrs.). 210-257-5564.

CALL TODAY - START tomorrow, ECK Miller expanding! Need flatbed drivers. All miles paid (new scale) life/health, rider/bonus program. 1-800-395-3510, owner/operators also welcomed!

DRIVER-BETTER RESPECT and a bigger paycheck! Get home often. Starting pay up to \$30/mile plus bonuses, assigned trucks benefits. Call anytime - Burlington Motor Carriers. 1-800-JOIN-BMC. EOE.

DRIVER/OTR TRACTOR/trailer 32e/MI guaranteed w/yds OTR experienced, out of last 6. Great benefits, Volvo/White assigned tractors, TSL 1-800-527-9568. EOE.

HAROLD IVES TRUCKING hiring drivers. Free driver training. Students welcome. Experience pay up to 28¢ per mile. 1995 conventional KW's here. Excellent benefits: 1-800-842-0853.

DRIVERS: FLATBED 48 state OTR. Assigned new conventionals, competitive pay, benefits. \$1,000 sign on bonus, rider program, flexible time off. Call Roadrunner Trucking 1-800-876-7784.

DRIVERS/0/0-LEASE program - no money down. Must meet company/DOT requirements. Late model walk-in conventionals. We're on the move (Texas div.) call 1-800-927-0431.

TRUCK DRIVERS DRIVE to own!! \$0 down or company drivers. Here's our new program. 78¢ all miles. Tractor ownership 30-42 months! Average 10,000+ miles/month! Company training program for students available. New Apple Lines, Inc. 1-800-843-8308/1-800-843-3384, Madison, SD.

ATTENTION DRIVER TEAMS \$15,000 in bonus. Paid monthly, quarterly & yearly plus top mileage pay, 401(K) plan. \$500 sign-on bonus. Other paid benefits \*vacation \*health & life \*dead head \*motel/layover \*loading & unloading. Covenant Transport, solos and teams call: 1-800-441-4394/915-852-3357. Students and driving school grads call: 1-800-338-6428.

WE BUY NOTES secured by real estate. Have you sold property and financed the sale for the buyer? Turn your note into cash. 1-800-969-1200.

CASH FOR REAL estate notes sell directly to First National and avoid payment commissions and points! Highest prices anywhere. Free quote Monday through Saturday. 1-800-501-FNAC.

FREEDebt CONSOLIDATION. Immediate relief! Too many debts? Overdue bills? Reduce monthly payment 30%-50%. Eliminate interest. Stop collection calls. Restore credit. NCCS, nonprofit. 1-800-955-0412.

CASH NOW! WE buy mortgages, trust deeds, land contracts. Sold property? Receiving payments? Get the cash you need now! Best prices! National Mortgage Buyers, Inc. 1-800-222-5199.

SUNQUEST WOLFF TANNING beds new commercial-home units from \$199. Lamps, lotions, accessories. Monthly payments low as \$18. Call today, free new color catalog, 1-800-462-9197.

STOP STRUGGLING WITH your weight. Specializing in difficult cases. \*Burns stubborn fat. \* Stops hunger. \* Increase energy. Call United Pharmaceuticals now. Save 20%, 1-800-733-3288, C.O.D.'s accepted.

20/20 WITHOUT GLASSES! Safe, rapid, non-surgical, permanent restoration in 6-8 weeks. Airline pilot developed, doctor approved. Free information by mail: 1-800-422-7320, 406-961-5570, FAX 406-961-5577. Satisfaction guaranteed.

PROSTATE; ARTHRITIS; DIABETES; and circulatory disorders discussed in Doctor's report on case studies of European food supplement. All natural. Call for free report copy, 1-800-310-3381.

CHILD SEXUAL ABUSE prevention in almost all areas, homes, schools, daycares and churches. Handbook \$19.99: SOCIO Info Resources, 15610 Empanda Dr., Houston, Texas 77083.

ADOPTION: YOUNG, HAPPILY married couple desires to give newborn the advantages of a loving home/family. Confidential. Allowed expenses paid. Call Leslie & Alan 1-800-557-9855. It's illegal to be paid for anything beyond Legal/Medical expenses.



**18--Services**

**AMARILLO-AREA PREGNANCY** Crisis Center Hotline. Call collect, 0-354-2244. Also Methodist Mission Home, 24 hours, toll-free, 1-800-842-5433. 18-4-tfc

**NEED YOUR TENNIS RACQUET RESTRUNG?**  
Call Brent or Bryan Portwood at 647-2541.

**25--Legal Notices**

**LEGAL NOTICE**  
Hart Independent School District is accepting bids for a 1995 two-wheel drive pickup. Bids will be opened in the office of the Superintendent Jan. 5, 1995, at 3 p.m. Bid specifications are available by calling 806/938-2143 or fax 806/938-2610 or writing Hart ISD, P.O. Box 490, Hart, Texas 79043.

MICHAEL T. SMITH  
Superintendent  
25-36-2tc

**LEGAL NOTICE**  
TO ALL INTERESTED PERSONS AND PARTIES:

You are hereby notified that SUNNYSIDE FEEDYARD has applied for Texas Natural Resource Conservation Commission (TNRCC) Air Quality Permit No. 26639. This permit, if approved, will authorize expansion of an existing Cattle Feedyard in Springlake, Castro County, Texas. The location of the existing facility is 14 miles south of Dimmitt on State Highway 385. This facility will emit the following air contaminants: odors and particulate matter.

A copy of all materials in the public file is available for inspection and reproduction at the TNRCC Amarillo Regional Office, Air Program, located at 3918 Canyon Drive, Amarillo, Texas 79109-4996, telephone 806/353-9251, and at the TNRCC Central Office, 12124 Park 35 Circle, Austin, Texas 78753, telephone 512/239-1000. The facility's compliance file, if any exists, is available for public review in the regional office of the TNRCC. Inquires about the permit application and any information concerning any technical aspect of this application can be obtained by writing Mr. Eric S. Chasteen, TNRCC Office of Air Quality, New Source Review Program, P.O. Box 13087, Austin, Texas 78711-3087 or the TNRCC Amarillo Regional Office.

You may submit written comments concerning the permit application to the Office of Air Quality, New Source Review Program in Austin. All written comments received within 30 days after the second publication of this notice shall be considered by the Executive Director in determining whether to issue or not issue the permit. All written comments will be made available for public inspection at the TNRCC Central Office in Austin. This notice is to be published on Dec. 15 and Dec. 22, 1994.

Any person who may be affected by emissions of air contaminants from the proposed facility may request the Commission to hold an informal public meeting and/or contested case hearing on the permit application pursuant to Section 382.056 (d) of the Texas Health and Safety Code. The Commission is not required to hold a contested case hearing if the basis of a request is determined to be unreasonable. All requests for a contested case hearing must be received in writing within the 30-day comment period regardless of whether an informal public meeting has been held or scheduled on this matter. If you wish to request a public hearing, you must submit your request in writing. You must state (1) your name, mailing address and daytime phone number; (2) the permit number or other recognizable reference to this application; (3) the statement "I/we request a public hearing"; (4) a brief description of how you, or the persons you represent, would be adversely affected by the granting of the application; (5) a description of the location of your property relative to the applicant's operations; and (6) your proposed adjustment to the application/permit which would satisfy your concerns and cause you to withdraw your request for hearing. Requests for a public hearing on this application should be submitted in writing to Office of the Chief Clerk, Texas Natural Resource Conservation Commission, P.O. Box 13087, Austin, Texas 78711-3087, telephone 512/239-3300.

Before a permit can be issued for this facility, the applicant must demonstrate that all emission sources are in compliance with all TNRCC air quality Rules and Regulations and all applicable Federal Regulations. This includes the application of "best available control technology" to each new or modified emission source and compliance with all ambient air quality standards. 25-36-2tc

**Dear Santa**

Dear Santa,  
I want a toy Santa doll. And I want a nintendo with games. And I want a new bike. And please don't forget to give my mamma and daddy something nice, too.

Love,  
FRANCISCO RUIZ  
7 years old

Dear Santa,  
I want a Hockey set and some new skates for Christmas and some new clothes and bring my mom something nice cause she really really needs it I hope Santa that you can really help me on my mom. I Love you Mom  
I ♡ U Santa! and Thank You.  
JUAN DIAZ

Dear Santa,  
I want a bike and a Beauty and the beast watch. I would like these things please.  
BRITTANY BIRKENFELD

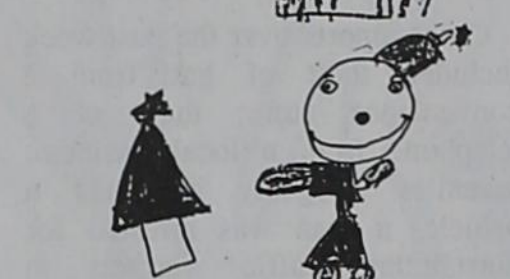
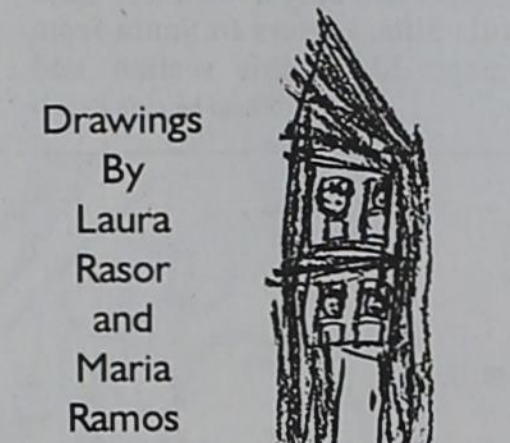
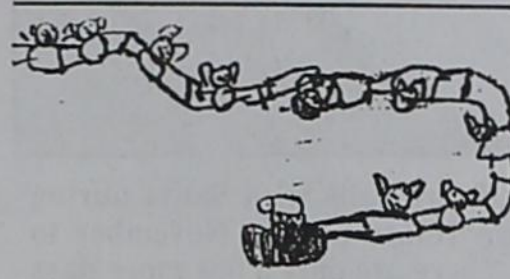

**Too Late To Classify**

**MUST SELL!** '93 Mercury Sable GS, automatic transmission, power windows, power door locks, AM/FM stereo cassette, tilt steering wheel, cruise control, driver's six-way power seat, dual air bags, rear window defroster and much more. No old contract to assume, no back payments to make. Just need responsible party to make reasonable monthly payments. Contact John Baxter in the Credit Dept., Friona Motors, 806/247-2701. 14-37-1tc

**MUST SELL!** '94 Ford Crown Victoria, 4-door, air conditioning, power driver's seat, power windows, power door locks, tilt steering wheel, cruise control, AM/FM stereo cassette and much more. No old contract to assume, no back payments to make. Just need responsible party to make reasonable monthly payments. Call Kim Humphrey in the Credit Dept., Friona Motors, 806/247-2701. 14-37-1tc

**MUST SELL!** 1991 Ford Aerostar Extended Van, 7-passenger seating, power windows, power door locks, automatic transmission, tilt steering, AM/FM stereo cassette, front and rear air conditioning, and much more. No old contract to assume, no back payments to make, just need responsible party to make reasonable monthly payments. Call Ismael Rocha in the Credit Dept., Friona Motors, 806/247-2701. ¡Se Habla Español! 14-37-1tc



Dear Santa,  
I want a Barney doll and a Baby Bop doll. And a baby doll that I can sleep with. Be careful and take care of your reindeer.  
Love,  
STEFFANY RUIZ  
3 years old

Dear Santa,  
I want a remote control car and a toy reindeer just like yours. And I want a Nintendo with some games, too.  
And please don't forget to give my Gramma and Grampa something nice.  
Love,  
CHRISTOPHER RUIZ  
4 years old

**For more Santa letters see Sections B and C**

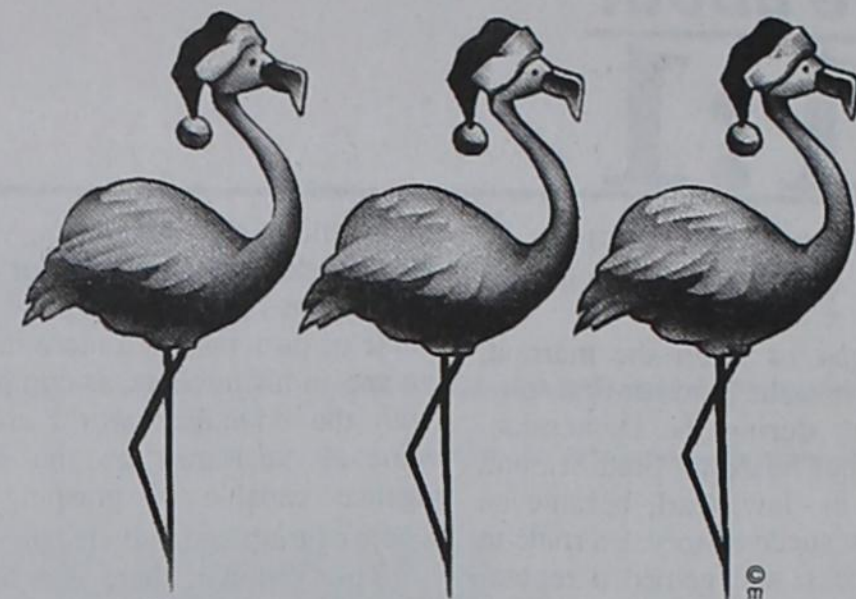

**three cheers for Christmas!**

Everybody, everywhere is getting into the holiday spirit and we'd just like to add our best wishes and hearty thanks for your patronage.  
Have a really terrific time!

**Paxton Tire & Service**

603 SE 3rd, Dimmitt • 647-4121

**ROOFING SYSTEMS.** For quality hail-resistant roofing, call Robert Duke at 647-5517. 18-44-tfc

**FREE**  
Pregnancy Test  
Confidential Counseling  
Problem Pregnancy Center  
505 E. Park Ave., Hereford  
Call 364-2027 or 364-5299 (Michelle)

**20--Help Wanted**

**LVNs NEEDED** for charge nurse positions in LTC facility. Contact Coleen Sewright, RN, DON at Hereford Care Center, 231 Kingwood, Hereford Texas 79045, phone 806/364-7113. 20-37-4tc

**DRIVERS NEEDED** for regional haul. Booker Transportation needs truck drivers for round trip meat hauls to Colorado, Oklahoma, Kansas and Texas. Our company is small enough to treat you like a human and not a number. If you like "to truck" but dislike the operations of a big company, give us a call at Booker, TX 800-569-4633, Monday through Friday, No. 19 20-37-6tc

**HAIRSTYLIST** needed. Full-time or part-time. Call 647-4159 or 647-5559. 20-24-tfc

**21--Wanted, Misc.**

**I WOULD LIKE TO BUY** your used gold jewelry—broken, worn out or otherwise. Call 647-3250, evenings. 21-1-tfc

**22--Notices**

**WEIGHT WATCHERS** is now meeting every Monday in Dimmitt. For more information please call 1-800-359-3131. 22-40-tfc

**24--Card of Thanks**

**CARD OF THANKS**  
I wish to express my thanks to all who took part in making my 90th birthday a very special event. Thanks for the cards, phone calls and especially to each one who attended our open house. God bless each of you.  
MARY LOU FRAZIER  
24-37-1tc

**CARD OF THANKS**  
Dear friends,  
Words could never fully express the respect, gratitude and appreciation we feel towards this community for all you have done during the loss of our mother, grandmother and great-grandmother, Juanita Bruegel.  
We would like to say a special thanks to Dr. Murphy, not only for his care and prayers, but also for allowing our family to participate in her care. Thank you, Dr. Patel and Dr. Hardee, for continuing the same quality of care in Dr. Murphy's absence. The loving attention of the Plains Memorial Hospital administration, nursing staff, kitchen and housekeeping departments was a vital contribution to her total well-being.  
A special thanks to Johnny Robertson and Paul Kenley for the many visits, words of encouragement and prayers.  
Last, but not least, our heartfelt gratitude goes out to the many friends who sent delicious food, beautiful flowers, memorials and loving visits. Mother has always had a great love and respect for this community and that same love and respect has been returned.  
THE FAMILY OF JUANITA BRUEGEL  
24-37-1tc

**25--Legal Notices**

**LEGAL NOTICE**  
NO. 2167  
THE ESTATE OF  
LORENZA LEE, DECEASED  
IN THE COUNTY COURT OF  
CASTRO COUNTY, TEXAS

**NOTICE TO ALL PERSONS HAVING CLAIMS AGAINST THE ESTATE OF LORENZA LEE, DECEASED**  
Notice is hereby given that the original Letters Testamentary for the Estate of LORENZA LEE were issued on the 7th day of December, 1994, in Cause No. 2167, in the proceedings of the Estate of LORENZA LEE, Deceased, pending in the County Court of Castro County, Texas, to MYRTLE LEE, HCR 2, Box 9, Hart, Texas 79043. All persons having claims against said estate, which is being administered in the County Court of Castro County, Texas, are required to send the same to me, at the above address within the time and within the manner prescribed by law.

MYRTLE LEE  
Independent Executrix  
of the Estate of  
LORENZA LEE, Deceased  
25-37-1tc

*Together We Can*

**HOPE SANTA IS GOOD TO YOU!**

*You've given us the gift of friendship, so we put in a good word with Mr. Kringle for you!*

*Thanks for everything and Merry Christmas!*

**Terra International**

We would like to wish all the good folks in Nazareth, Dimmitt, and the rest of Castro County a Merry Christmas and a Happy New Year!!!  
We appreciate you letting us participate in Suds 'n' Sounds, Harvest days, and many, many weddings. We're looking forward to seeing all of you in 1995!!

- Jerry "JJ" Jenkins
- Charley "Hoss" Couch
- Todd "Rowdy" Tolbert
- Rick "Doc" Faucett
- Steve Breithaupt

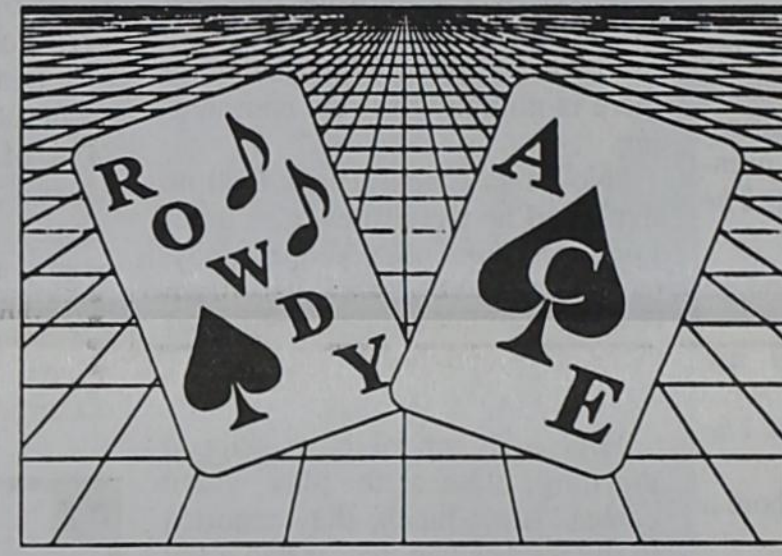

**One Solitary Life**

*He was born in an obscure village, the child of a peasant woman. He grew up in still another village, where He worked in a carpenter shop until He was thirty. Then for three years He was an itinerant preacher. He never had a family or owned a home. He never set foot inside a big city. He never traveled two hundred miles from the place He was born. He never wrote a book, or held an office. He never went to college. He did none of the things one usually associates with greatness.*

*He was only thirty-three when the tide of public opinion turned against him. His friends deserted him. He was turned over to his enemies, and went through the mockery of a trial. He was nailed to a cross between two thieves. While He was dying, his executioners gambled for the only piece of property he had - his coat. When He was dead, He was taken down and laid in a borrowed grave through the pity of a friend.*

*Nineteen centuries have come and gone, and today He is the central figure for much of the human race. All the armies that ever marched, and all the navies that ever sailed, and all the parliaments that ever sat, and all the kings that ever reigned, put together, have not affected the life of man upon this earth as powerfully as this "One Solitary Life."*

Although this poem has become popular in recent years, it is not a contemporary piece. The poem actually has tracings back to medieval times, and the poet to this day remains anonymous.

**We pause to reflect on his life during the Christmas Season, and celebrate his birthday on Christmas Day.**

*Merry*  
**Christmas**  
from  
**SWISHER ELECTRIC COOPERATIVE**



More about

1:1

(Continued from Page 1)

easy life. She didn't ask for it to be easy.

She was 14 when she married, and 15 when she bore her first son.

Starting during the Depression, she and her husband, Fred Sr., and brother-in-law, Carl, became an American success story. En route to that success, she gained a reputation of being the best combine mechanic in the county.

She was barely into her 30s by the time Fred Jr. and Carl were finishing high school. She decided she wasn't ready for an empty house, so she had Sandra and Mike, and went through the whole child-rearing process again.

The Bruegel home was always one of the friendliest homes around, and was always open to us through the years—for a party, a get-together or just a drop-in coffee break.

Before Verbie and I married, she hosted the bridal shower. Verbie wasn't accustomed to Dimmitt-style bridal showers. It was overwhelming to her, and she had to sneak back to the kitchen for a cry. Juanita sneaked back there with her.

It was a tribute to her that the First United Methodist Church was packed for her funeral. And I imagine that everyone there had their own good memories of how she had touched their lives.

The famous editorial, "Is There a Santa Claus?" first appeared in the *New York Sun* on Sept. 21, 1897. It was written by Francis Pharcellus Church, an assistant to the *Sun's* editor.

We all need to re-read it every once in a while. In case you haven't seen it elsewhere this Christmas season, here it is:

IS THERE A SANTA CLAUS?

"We take pleasure in answering at once and thus prominently the communication below, expressing at the same time our great gratification that its faithful author is numbered among the friends of *The Sun*:

'Dear Editor:  
I am 8 years old.  
Some of my little friends say there is no Santa Claus.

Papa says, "If you see it in *The Sun*, it is so."

Please tell me the truth, is there a Santa Claus?"

Virginia O'Hanlon  
115 West 95th Street

"Virginia, your little friends are wrong. They have been affected by the skepticism of a skeptical age. They do not believe except what they see. They think nothing can be which is not comprehensible by

their little minds. All minds, Virginia, whether they be men's or children's, are little. In this great universe of ours man is a mere insect, an ant, in his intellect, as compared with the boundless world around him, as measured by the intelligence capable of grasping the whole of truth and knowledge.

"Yes, Virginia, there is a Santa Claus. He exists as certainly as love and generosity and devotion exist, as you know that they abound and give to your life its highest beauty and joy. Alas! how dreary would be the world if there were no Santa Claus! It would be as dreary as if there were no Virginias. There would be no childlike faith then, no poetry, no romance to make tolerable this existence. We should have no enjoyment, except in sense and sight. The eternal light with which childhood fills the world would be extinguished.

"Not believe in Santa Claus! You might as well not believe in fairies! You might get your papa to hire men to watch in all the chimneys on Christmas Eve to catch Santa Claus, but even if they did not see Santa Claus coming down, what would that prove? Nobody sees Santa Claus, but that is no sign that there is no Santa Claus. The most real things in the world are those that neither children nor men can see. Did you ever see fairies dancing on the lawn? Of course not, but that's no proof that they are not there. Nobody can conceive or imagine all the wonders there are unseen and unseeable in the world.

"You can tear apart the baby's rattle and see what makes the noise inside, but there is a veil covering the unseen world which not the strongest man, not even the united strength of all the strongest men that ever lived, could tear apart. Only faith, fancy, poetry, love, romance can push aside that curtain and view and picture the supernal beauty and glory beyond. Is it all real? Ah, Virginia, in all this world there is nothing else real and abiding.

"No Santa Claus! Thank God he lives, and he lives forever. A thousand years from now, Virginia, nay, ten times ten thousand years from now, he will continue to make glad the heart of childhood."

Four high school boys skipped morning classes to play video games. After lunch, they reported to the teacher that the car had a flat tire on the way to school.

Much to their relief, she just smiled and said, "Well, you missed a test this morning, so take seats apart from each other and get out your notebooks."

Still smiling, she waited for them to settle down. Then she said, "First question: which tire was flat?"



**TIME FOR SANTA**—An unidentified girl visits with Santa during the Dimmitt Merchants' annual Open House held in November to start off the holiday shopping season. There are only a few more days remaining to finish off those last minute gifts. Letters to Santa from local youngsters are included on page 13 of this section and throughout Sections B and C.

Photo by John Brooks

More about

Police . . .

(Continued from Page 1)

injuries were discovered he was released.

A parked pickup was struck by a 1981 Oldsmobile driven by Perry Walker, 25, of Clovis, N.M.

The pickup, owned by Leroy Maxwell, was unattended at the time and legally parked in the street. Walker's car apparently stalled as it turned north from Bean St. onto SW Sixth, then struck the 1976 Ford pickup.

A Dimmitt woman was cited for an unsafe turn when she turned in front of a car driven by Yolanda Moran, 24, of Dimmitt.

Mary Mays was cited for turning when unsafe in the accident on the morning of Dec. 14. She told police she did not see the 1985 Chevrolet driven by Moran. The accident occurred at Fourth and Halsell.

Other reports over the past week included theft of gas from a convenience store; theft of a telephone from a local business; juveniles allegedly scratched a vehicle; a man was arrested for outstanding traffic warrants in Randall County; someone damaged a detour sign on SH 86; a man was alleged to have been driving while intoxicated; a battery was stolen from a car in the 800 block of SW Fourth; criminal mischief in the 700 block of SW Fourth, where someone broke out a back windshield of a car; and unauthorized use of a motor vehicle.

Thank you for shopping Dimmitt!

Don't Wait For A Crisis

No one plans an accident or illness. By completing an advance directive you can specify medical care you do, or don't, want.

Make your wishes regarding medical care known now. Contact your physician or local hospital today about advance directives.

It feels good to plan ahead ...if only you will.

Brought to you by the Texas Hospital Association.

Obituaries



Juanita Bruegel

Juanita Bruegel, 76, of Dimmitt, died Dec. 14.

Services were Thursday at First United Methodist Church in Dimmitt with the Rev. Johnny Robertson, pastor, officiating. Burial was in Castro Memorial Gardens by Foskey Funeral Home of Dimmitt.

Mrs. Bruegel was born March 2, 1918 in Portales, N.M. She moved to Castro County in 1925 from Portales. She married Fred Bruegel Sr. on April 7, 1932 in Portales. He died on Dec. 13, 1983. She was also preceded in death by a grandson, Gary Bruegel.

She was a longtime member of First United Methodist Church, Rebecca Lodge, and was a charter member of the Plains Memorial Hospital Auxiliary and the Republican Organization for Women. She served on the board of trustees for the Castro County Hospital District from 1986 to 1988. She was active in the Bethel community and taught Sunday School in the Bethel community.

Survivors include three sons, Fred Bruegel Jr. and Carl Bruegel, both of Dimmitt, and Mike Bruegel of Amarillo; a daughter, Sandra Baker of Dimmitt; a brother, Joe Cox of Caruthers, Calif.; 13 grandchildren; and nine great-grandchildren.

Pallbearers were Mark Bruegel, Jon Bruegel, Curtis Bruegel, Michael Bruegel, Andy Kemp and Blake Cox.

The family requests memorials to the Gary Bruegel Scholarship Fund in care of First United Bank, PO Box 929, Dimmitt, TX 79027.

Gerry Chaney

Gerry Chaney, 76, died Thursday. Services were Sunday in Fourth and Bedford Street Church of Christ with Harry Riggs, minister, and Ronnie Parker officiating. Burial was in Castro Memorial Gardens by Foskey Funeral Home.

Mrs. Chaney was born in Dodd City. She lived in Quail before moving to Dimmitt in 1959. She married Earl Chaney on April 28, 1940 at Paris. He died June 11, 1987. She was a member of Fourth and Bedford Street Church of Christ. She was a retired secretary.

She was also preceded in death by a sister, Mary Turner.

Survivors include a son, Michael Earl Chaney of Friona; a daughter, Sue Chaney Battles of Colleyville; three sisters, Gwendolyn Howell of Windom, Catherine Elliott of Longview and Ruth Dykes of Odessa; and four grandchildren.

The family suggests memorials be to a favorite charity.

Tim Chavers

Abram Lee "Tim" Chavers, 56, of Weatherford, died Dec. 13.

Services were Saturday at Galbreath-Pickard Funeral Chapel in Weatherford with the Rev. Curtis Jefferson officiating. Burial was in the East Greenwood Cemetery in Weatherford.

Mr. Chavers was born Jan. 21, 1938 in Groesbeck. He lived in Dimmitt for many years before moving to Weatherford 14 years ago. He was a truck driver and a member of New Hope Baptist Church.

Survivors include his wife, Yolanda, of Weatherford; two daughters, Karen Chavers and Beverly Chavers, both of Fort Worth; four sons, Timothy Chavers and Anthony Chavers, both of Fort Worth, and Brian Chavers and Aaron Chavers, both of Weatherford; his mother, Cassie Chavers of Weatherford; five sisters, Claudia Brady of Mineral Wells, Frances Mason, Loreta Williams and Vertie King, all of Weatherford, and Kathryn Gordon of Fort Worth; five brothers, Billy Chavers of Fort Worth, Lee Edward Chavers, Claude Chavers Jr., and Nelson Chavers, all of Dallas, and Gene Chavers of Ohio; and four grandchildren.

L.A. McManus

L.A. McManus, 72, of Amarillo, died Dec. 13.

Services were Friday in Memorial Park Funeral Home Chapel of Memories with the Rev. Johnny Robertson, pastor of First United Methodist Church in Dimmitt, officiating. Burial will be in Memorial Park Cemetery.

Mr. McManus was born in Lorenzo and moved to Amarillo in 1946 from Melrose, N.M. He married Fay Curtis in 1942 at Melrose. He served with the Army Air Corps in World War II. He was a sheetmetal mechanic for Plains Plumbing for 25 years and retired in 1984. He was a Baptist.



Survivors include his wife; two daughters, Carolyn Babb of Dallas and Connie Merritt of Dimmitt; a sister, Dorothy La Mark of Chula Vista, Calif.; five grandchildren; and two great-grandchildren.

Too Late To Classify

FOR SALE: 160-acre irrigated farm. Excellent yields. 4-1/2 miles southwest of Sunnyside. Irrigation equipment including 1990 model T&L 7-tower center pivot. Call Howard and Oleta Gwinn, Coldwell Banker Paxton Real Estate, 1-800-560-9626. 2-30-tfc

Classifieds gets results

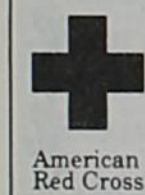
Get Out, Stay Out: Your Fire Safe Response

**TWO INJURED IN ACCIDENT**—Two persons received slight injuries in an accident Thursday afternoon at Grant and SW Fourth. This 1983 Chevrolet station wagon driven by Bessie Andrada, 22, of Dimmitt, was going north on SW Fourth when it was struck by an eastbound 1992 GMC pickup

driven by Laura Bradford, 14, of Dimmitt. A person in each vehicle was slightly hurt, and both drivers were ticketed: Bradford for no driver's license and failure to yield right of way and Andrada for no liability insurance.

Photo by John Brooks

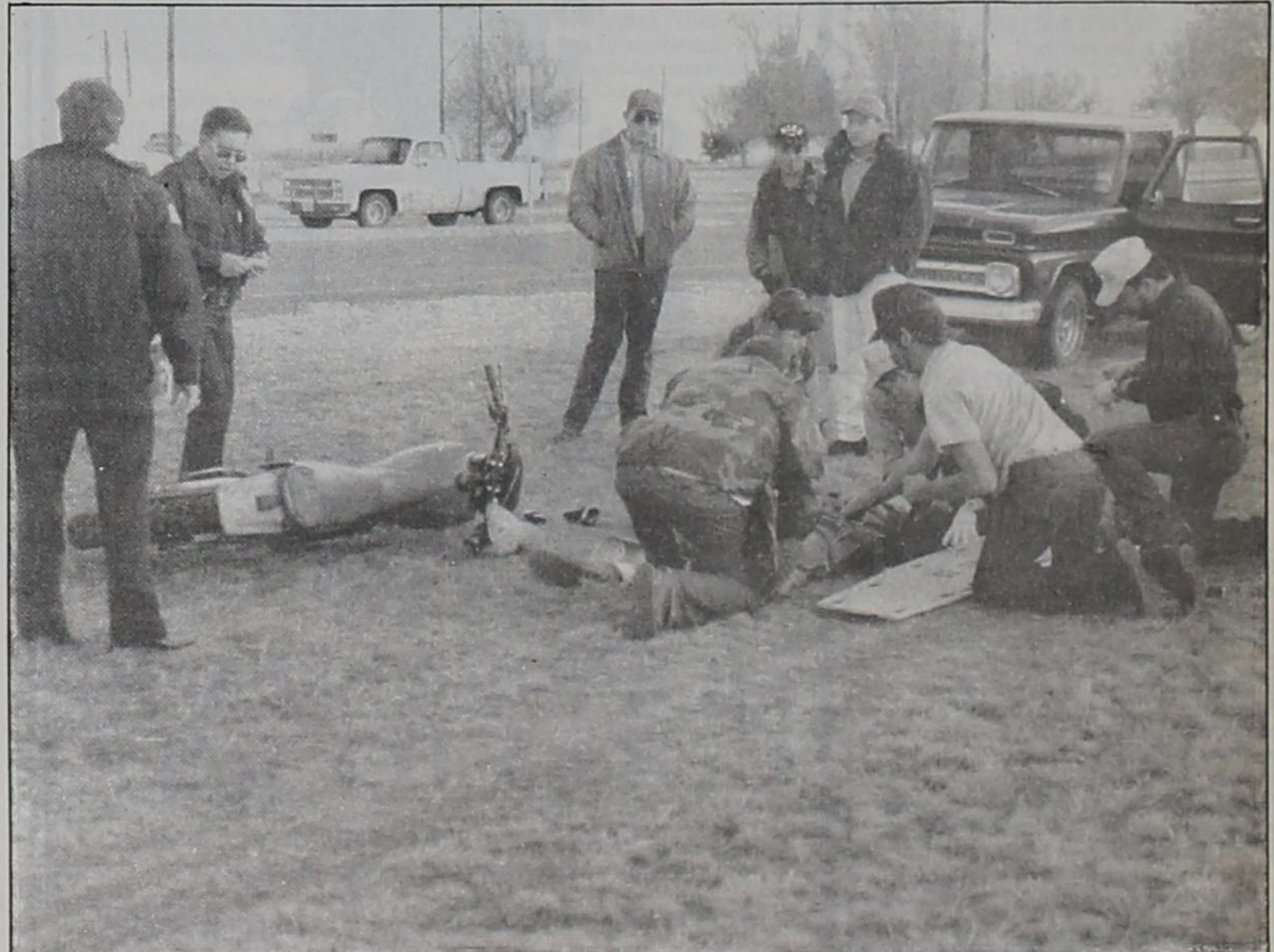

**TEEN HURT IN MOTORCYCLE MISHAP**—Joel Townsend, 14, of Dimmitt, was injured Thursday afternoon when the motorcycle he was riding flipped. He was riding on private property near the intersection of US Highway 385 and State Highway

194 when he crossed an alley. The front wheel of the motorcycle hit a small rise and flipped Townsend. He was treated at Plains Memorial Hospital and transferred to another hospital for an MRI to check for further injuries.

Photo by John Brooks



# The Castro County News

70th Year—No. 37

Dimmitt, Texas, Thursday, December 22, 1994

50¢



*Angels and archangels proclaim the miracle. Lift your spirits and voices in song, for Hallelujah, Christ is born!*

*We hope your spirits will be lifted by the magic, the excitement and the spiritual meaning of Christmas.*

*Following a cherished custom here, we have donated to the Plains Memorial Hospital Auxiliary instead of sending individual cards locally. It is our hope that our donations will benefit your family and ours in the future. This is our card to you, and our gift to our community.*

*Best wishes to you, from all of us, for a joyous season!*

Joyce Adrian  
 Sonny & Ann Armstrong  
 Michelle Bailey  
 Arthur Bailey  
 Kate Beecher  
 Pauline Bell  
 William & Rosetta Bellinghausen  
 Mr. & Mrs. Elmer Berryhill  
 Bill & Kathryn Birdwell  
 Johnnie Boothe  
 Monty & Sue Boozer  
 Chet & Helen Braafladt  
 Mildred Bradford  
 Jack, Susie, Laura & Sarah Bradford  
 Ray & Allan Bradley & Family  
 Gene, Shari & Mary Bradley  
 Bill, Debra & Christopher Bridenbaugh  
 J.R. & Mary Jo Brown  
 Fred & Bobbie Bruegel  
 Carl & Gail Bruegel  
 Marvin, Gwen & Bruce Bryant  
 Dugan Butler  
 Patti, Logan, Angela & Elizabeth Cartwright  
 Jerry, Lucy & Mark Casares  
 Emily Clingsmith  
 Billie Cluck  
 Mary & Susie Cluck  
 Retta Cluck  
 Ruth Coleman  
 The Bill Conyers Family  
 Don & Shirley Cornett  
 Genell Craig  
 Virginia Crider  
 Bob, Jackie & Sue Crozler  
 Aural Davis  
 Decimae Dennis  
 Ferne Dickey

Salvatore & Carnelle DiCuffa  
 James & Doris Dobbs  
 Bryce & Darlene Dowell  
 Jack & Jan Edwards  
 Jim Bob, Cindy, Blake & Chad Ellis  
 Edward, Sharon, Shawn & Chad Ewing  
 CD & Linda Fitzgearld  
 Jack & Doris Flynt  
 Cleo Forson  
 The Mike Foskey Family  
 Alvin & Frances Frazier  
 Ed & Betty Freeman  
 Kenneth & Linda Frye  
 Nancy, John & Amy Fuller  
 Paul & Ortensia Garcia & Family  
 Coby & Connie Gilbreath  
 Matt & Ronda Gilbreath  
 Dorothy Gilbreath  
 Hal & Richele Gilbreath  
 Clara Gladden  
 Jan & Bill Glenn  
 Oleta Gollehon  
 Vincent Guggemos  
 Leon & Billie Gunn  
 Billy & Ruth Hackleman  
 Mozelle Lilley Hall  
 Don & Mae Hargrove  
 Glenn, Diane & Tracy Hatla  
 Bill & Ann Henderson  
 Maurine Henderson  
 Mary Edna Hendrix  
 Ben & Bernice Hill  
 James R. & Jerrie Horton  
 P.L. & Pauline Hoyler  
 David & Karen Hutson  
 R.V. & Dolores Ivy  
 Carolyn Jones

Geneva Justice  
 Paul, Barbara & Nikki Kenley  
 Gene & Mary Nell King  
 Fred & Helen Kuntz  
 Ricky Kuntz  
 Florene Leinen  
 Houston & Doris Lust  
 Kenneth & Mary Nell Malone  
 Roger & Geneva Malone  
 Jerry & Sherri Matthews  
 Leroy & Linda Maxwell, David & Melissa,  
 Daniel & Mindy  
 Clint & Catherine McFarland  
 Jackie McLeroy  
 Mrs. Louise Mears  
 John & Sue Merritt  
 Ron & Irene Miller  
 Don & Carolyn Moke  
 Coby & Kendra Moke  
 Phyllis & Bob Mooney  
 Thelma & J.B. Moore  
 Ron & Janet Morgan & Family  
 Dr. B.D. Murphy  
 B.M. Nelson  
 Don & Verbie Nelson  
 Lucy Nelson  
 Don & Colleen Newman  
 Mr. & Mrs. John Nino & Family  
 Tommie Sue Nisbett  
 Arlie Petty  
 Sue Phillips  
 Tommy, Paula, Brent & Bryan Portwood  
 Cindy & Mike Pottorff  
 George, Linda, Laura & Michael Rasor  
 Bryan, Donna, Lana & Adam Reinart  
 Edna Reinart  
 Danny & Shelly Rice, Tisha, Brandi & Ramey

David & Sherry Schaeffer & Family  
 Mr. and Mrs. Stanley Schaeffer  
 Donald & Agnes Schilling  
 Jewell Scott  
 Delbert & Lois Scott  
 Mattie Seale  
 Dorothy Sheffy  
 Andy & Oleta Shumacher  
 George & Carolyn Sides  
 Gregg & Lynn Sides, Kate, Ben & Mo  
 Mary & Gene Smith  
 Pete, Darla & Brian Stewart  
 Raleigh & Grace Strother  
 Gerald & Patty Summers  
 Charlie & Sue Summers & Family  
 Juanita & Melvin Summers  
 Eddie & June Sutton, Stuart, Justin & Houston  
 Cathy Thames  
 W.E. Thornton  
 J. Paul & Gertie Waggoner  
 Lois Waggoner  
 Bettye Wallace  
 Una Ward  
 Mr. & Mrs. Jerry Watts  
 Carroll & Waldine Webb  
 James & Reta Welch  
 G.L. Willis  
 John & Margaret Womack  
 Lester, Eileen & Allsha Womack  
 Rex Wooten  
 Donald & Katy Wright  
 Mauzee Youts







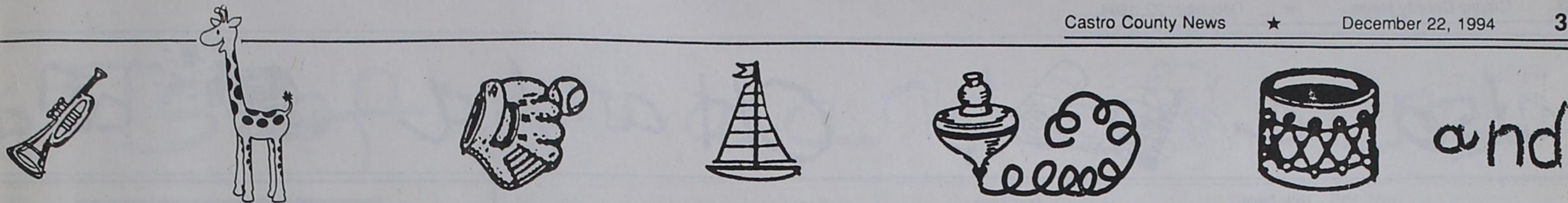

Dear Santa,  
I'm in third grade. I'm 9 years old. I'm wanting a pair of roller blades and a pair of roller skates and a bike. But most of all I want a cat and I want my grandpa to live with us all his life. I wish my mom could win the lottery. I wish that my brother gets his shoes. I wish that he gets to be a foot ball player and I wish I'm a cheerleader or a nurse or a teacher like Mrs. Bain, Miss Thames or Mrs. Kieth. I wish that my grandma and my great, great grandma and my uncle hadn't died. I will leave you cookies and a glass of milk. Also I like to read books.

Your friend,  
KIMBERLY ANN PAZ

Dear Santa,  
I am in third grade. My name is Whitney Nutt. I am pretty nice this year. I want to know if the reindeer get presents on Christmas Eve. For Christmas Eve I want a desk. The other present I want is roller blades with knee pads, elbow pads, and a helmet. For your christmas I will make you cookies with milk. How do you give all the children presents in one night? Will all the children wake up? Do your elves get tired of working? For Christmas I want to have a good Christmas.

Your third grade friend,  
WHITNEY NUTT

Dear Santa,  
I am a 9 year old boy. The thing I want most is a Harley Davidson bike. I already have a Motor sike bike. The thing I wanted last year was a chemistry set. I also want all the Power Rranger set and the Power Rranger Zords. The three things I want is a Go-cart and a Motorcycle and a Sega. Santa, do not for get the children in Africa.

Your friend,  
ANTHONY ZAMBRANO

Dear Santa,  
I am nine years old. My best friend is Kris Lindsey and I am in third grade. My teacher's name is Mrs. Bain. She is a good teacher. She plays games with us. I want a little desk tht I can do my homework on and a pack of markers and play money and the very best thing I want for Christmas is a Go cart. How is Mrs. Santa Claus?

Your best friend,  
ADAM WRIGHT



Dear Santa

I am 9 years old. I wish I can have a bike that glows in the dark and a Sega C.D. I already have a Sega, but I wanted a Sega C.D. You don't have to bring it but if you want to bring it you can. I will leave some cookies and milk on the table for you.

Love your friend,  
ADAM SAUCEDO

Dear Santa,

Hi, my name is Kaitlyn Metayas and I am 2 years old. I want a new bow, a baby dollie, some boots like Daddy Bry-Bry, a book, a Power Ranger Watch.

Love,  
KAITY

Dear Santa,

I am in third grade. I've been helping my mom a lot everyday at home. How is Mrs. Santa doing? I hope everything is okay over there. I am nine years old, Next year I'm ten year old. My name is Denise Perez. For Christmas I want a disc player and I want a lamp and a desk and clothes for my Barbie too. The things I really want is a disc player and a canopy bed, but I might mess it up. I'd also like to have a bike for Christmas.

Love,  
DENISE PEREZ

P.S. Thank you Santa.

P.P.S. I hope you have a safe Christmas.

Dear Santa,

I am a boy in the third grade. How is Rudolph? Is it cold at the North Pole? here in Dimmitt it is a little cold. In some places it is already snowing. I wish that I had a Go Court for Christmas. And I wish that I had a Sega, a new bike and a new B.B. gun Do not forget the other girls and boys in Laredo, Dallas, and Amarillo, Texas.

Love,  
RAMON AGUERO

Dear Santa,

I am a third grader and my teacher's name is Mrs. Bain. I am nine years old. I am a good girl for Mrs. Bain, and I am a good girl for my parents and I help my table pick up trash from the floor. I will give you the address if you want to come over and eat some cookies with milk. It will be good. You could come with your wife and your elves and I really want you to bring your reindeers. I would want a pair of shoes, clothes, Saga, Barbie and that is all that I want this year. How is Mrs. Santa and you little elves and reindeers? I hope they are doing good. Tell Mrs. Santa that I said Hi. And if your wife and your elves come I will have something for them and I even have something for you but I won't tell you what it is until Christmas. I will tell you my address after I finish my writing. I forgot to tell you that I even want a stereo with a big T.V. I hope your helpers are doing some good work for you. I hope your wife and your elves are doing good. I even want you to tell your elves that I said Hi! Tell them that I said for them to do good stuff for you and your wife. Here is my address—309 SW 6th Good bye. I have to go.

Your friend,  
VALENTINA LUGO

Dear Santa,

Hello, my name is Jordan Metayas and I am 4 years old. I want boots, a new game, a Power Ranger watch, some new jeans, Biker Mices and Some new baseball clothes like a purple one or a green one. Some new shirts, a new lighter for Bryan, new plates for Mommy and some new drums for me. Another drum for my sister Kaity. I also want some new roller blades with training wheels. That's all.

Love,  
JORDY

Dear Santa,  
I am 8 years old. I want a Go-Cart for Christmas. I am in third grade in Mrs. Bain's class. Who is driving the sled? Is it Rudolph? How are the Elves and how is Mrs. Claus? How many toys do you make? Is it cold when you come.

Your friend,  
Luis Cruz

Dear Santa,

I am in the third grade and I am eight years old. How are you doing at the North Pole? how is Mrs. Santa and your elves? How are your nine reindeers? I hope they are fine. How do you go through the snow and the chimneys. I want a Gameboy, some clothes and a Saga Genesis game. Bye for now.

Your third grade friend,  
CHRISTINA CAMPOS

Dear Santa,

I am 8 years old. This is what I want for Christmas. I want some clothes, Roller blades, shoes, and a dollhouse. How many elves do you have? I wish I would win the lottery. I wish I had a Game Boy, but what I want most of all is a Sega. Well I hope Mrs. Santa is alright. I am going to Leave some cookies and milk.

Love,  
MARIA IBARRA

Dear Santa,

I am a boy who is in the third grade and my teacher is Mrs. Bain. How are you doing? Are you getting ready for Christmas? This is what I want for Christmas, I want a super Nintendo game. the name of it is John Madden 95, an erector set, the Rickasha, and some clothes. I want a C.D. player and some tapes like country and rap. and I want some other things.

Your new friend,  
KRIS LINDSEY

Dear Santa,

I am in Mr. Soliz' second grade class. I have been a good girl. I want a Happy Hiday Barbie, shoes, clothes, computer, and I wish you and your helpers a Merry Christmas.

Love,  
NYSSA

Dear Santa,

All I want for Christmas is for everyone to be happy. Thank you for my horse, Bully. He died. How are you doing? I'm Amy McGowne and I'm in the third grade. I can not wait till Christmas. One more thing—I have some new roller blades for Christmas? How is Mrs. Santa doing? I hope none of your reindeer or elves are sick. Santa please go see the poor people this year. Did Rudolph get some friends? go by Mrs. Bain's house and give her a present, too. She has been a good girl this year. I hope I have too. If I have not do not give me nothing Ok. Have a safe Christmas.

Love,  
AMY MCGOWNE

Dear Santa,

I have one brother and his name is Eric. He is in 7th grade. My mom's name is Mary. I have a dad too. His name is Lee. He lives in Amarillo. My mom and brother and I live in Dimmitt Tx. Santa, all I want for Christmas is for my whole family to get back together. I would also like a C.D. Walkman, Barbie, a Barbie house, a real horse, and a lot of clothes.

Your friend,  
ANGELA GOMEZ

Dear Santa,

Hi, how are you doing? I'm doing good. How is Mrs. Santa, your wife? My mom is doing good. How are your little elves. I want roller blades. I just remembered your reindeer. How are they doing? I want a 10 speed bike.

Your friend,  
ASHLEY SAENZ

Dear Santa,  
I am a girl in the third grade. Are you almost done with the toys? I have been a good girl this year. Could you please bring me a talking Barbie, computer, Game boy, Trampoline, Play School Doll House and some clothes. How is Rudolph? how is Mrs. Claus? Is it cold in the North Pole? When you come in, I will leave you some cookies and milk on the table. Have a safe ride.

Love You Always,  
ANGELICA LARA

Dear Santa,  
I'm in third grade. Mrs. Bain is my teacher. I'm wondering if your elves are o.k. santa I would like a super soaker 2,000, some clothes and new baseball cards. I might get a B.B. gun for Christmas and a new dog. I want it to be a pit bull. Don't forget the treats and a bag of candy. Don't forget the people in New York City.

Love,  
JOHNNY MIRELES



## Cheers To You!

We value your friendship, loyalty and support.  
Hoping your season is merry!

**Corner Place Package Store**  
Don and Shirley



## Away In A Manger

*On a night like no other before or since,  
the world was changed forever.  
We're pleased to join you in celebration  
of that blessed event, and to offer our thanks  
for your kind patronage.*



**Coleman Pharmacy**

201 NW 2nd St., Dimmitt

647-3151

**Thanks  
For  
Dropping  
In On Us!**

*We want to take this  
opportunity to deliver our  
gratitude for your  
patronage throughout  
the year.*

*We truly appreciate your  
gift of friendship.*

*Have a wonderful  
holiday season!*

**Bryant's  
Sales & Service**

315 N. Broadway, Dimmitt  
647-3149

## It's Beginning To Look A Lot Like Christmas!

Opportunity's knocking  
And we'd just like to say,  
Hope your season is perfect  
In every way.

May it open the door,  
For good tidings and cheer --  
Merry Christmas to all  
And a joyous New Year.

**Schaeffer, Sutton  
& Schaeffer**

## DECK THE HALLS



*Hang up the holly...  
String up those lights...  
Wrap up the presents...  
That are sure to delight...  
Share the warm fire...  
With someone you love,  
And give thanks for these blessings  
To the good Lord above!*

*Merry Christmas from all of us.*

**Dimmitt  
Ready Mix**



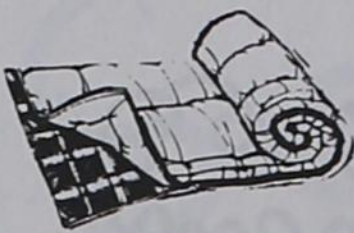

also a  OH and a  and

**Dear Santa,**  
I wot a scabod. Please. I bin gud. i wot a parazz move. I wot too ride rodof. duz rodof hav th at red noze. i wot a segaed.  
Iuv,  
KEVIN JACKSON

**Dear Santa**  
I want a new nintendo game, a new belt, a biker mice blazencycle, a power ranger game watch, and a new red dragon zord.  
love,  
JIMMY

**Dear Santa,**  
Hi! I am Carrie Ann Armstrong and I'm 5 years old. I want a umbrella, a new watch, and some new roller skates. I want some new boots and new jeans and a new shirt. I want cheerleader clothes. I want a new doll too and some new Tapes for dad and cowgirl rope and shirt and pants and cowgirl hat.  
Love,  
CARRIE

**Dear Santa,**  
I've been good and would like to have some black jeans, other clothes, books and bedclothes.  
Love,  
Brittany

**Dear Santa,**  
I am excited about Christmas. I know that you are watching. I have been good this year. For Christmas I would like a white Power Ranger and a race car. Please be sure to leave a gift for every boy and girl around the world. I will leave milk and cookies for you. I like to play power rangers. I like play toys at school.  
Your friend,  
Jorge Olmos

**Dear Santa,**  
I am in the third grade and I am a girl. My teacher is Mrs. Bain. She has been nice so if you come past her house, then you might want to stop on her roof and drop a present in her house. Make sure that it says from Santa to Mrs. Bain and make sure that it goes under her tree. How are your rein-deers doing? how do you go all the way around the whole world in one night? Do you know what I want for CHRISTMAS? I want a ten-speed bicycle and I also want a game. I really don't care what kind of game you give me. I also will have a surprise for you at my house. Well I've got to go so bye dood.  
Your third grade friend,  
HEATHER DIANE HARGROVE

**Dear Santa,**  
I want for Christmas Power Rangers and Creepy Crawler a jeep for my sister and a necklace for my mom.  
Thank you.  
Aaron Arcos

**Dear Santa,**  
I have been very good this year. I would like it, if you would bring me a pocket arcade, tv-vcr, and a bike with lights in the front. Thank you.  
Love,  
Luis

**Dear Santa**  
I lik sanclaus. I wot a bike for crismnes ebe. I didet poot the crismnes trisne. I wot a dol. I WOTA LITL NECLIS. I em nis do you lik to wrk. I wot a pige bak. I wot a lil play toy.  
Love,  
Isela Velo

**Dear Santa**  
I wot a brabe for Christmas and a gamboy for Christmas. My mom is goe to get us to pez for Christmas.  
Love,  
Melissa Campos

**Dear santa**  
I want a power ranger game. I want a game ger. I want a lion king game. I want a dog. I want new close. I want a game boy. Thats ol i want. Merry Christmas.  
Love,  
Nicholas Ortiz

**Hello Santa,**  
i want these few things for you to bring me. A my-size Barbie, a Power Rangers blanket and pillow, and a VCR. That's all.  
Your friend,  
JULIE RODRIGUEZ

**Hello Santa,**  
I Love you. I want a Power Ranger. I want car. That's all.  
Your friend,  
ADRIAN VASQUEZ

**Hello Santa,**  
I want a jeep for Christmas, and a red Power Ranger. That's all.  
Your friend,  
MIKEY SARABIA

**Hello Santa,**  
I want a black shirt and brown pants, and purpl Cowboy boots and shoes.  
Your friend,  
DANNY GUERRERO

**Dear Santa,**  
Will you bring me a my-size Barbie and a bicycle and a clock to wake me up and a twirling Barbie and Barbie clothes. I Love you.  
BRITTANY NELSON

**Dear Santa Claus,**  
Santa Claus I want a Aladdin dress and Beauty and Beast dress, and My Christmas Barbie and a new sweater and a my-size Barbie and Camping Barbie with a van, and a computer and a boom box and a new watch and 2 more things, a new kitchen and some dishes, uh one more thing a new book case.  
Your friend,  
ANDREA PANTOJIA

**Hi Santa,**  
I want a Water Barbie. Good-bye.  
JOSIE CHIA

**Dear Santa,**  
Hello. I want a jeep and Blue Power Ranger and Red Robot and an airplane, a for reals airplane, a blue gun.  
Your friend,  
JOHN PAUL MENDEZ

**Dear Santa,**  
I love you. I want my-size Barbie, Barbie that spins around with Ken or without Ken, exercise Barbie, a flower maker, jewelry maker, a Bake-Shop.  
Your friend,  
KRISTI MILLER

**Dear Santa,**  
Please bring me a bike and mom a knew bed, and my dad a truck. My brothe's and sisters' a power ranger bed, game gear, magic oven, bike, puppy, doll, play tools, barbey.  
Love,  
Jackie

**Dear Santa,**  
for Chirmsas I want a Sata Cluas suit and a baribe care, baribe dall, shoes, clothes,  
Love,  
Martha

**Dear Santa,**  
I have been a good girl this year so can you please bring me a computer so I can play and leard with it, and I want some boots and a Jacket.  
Love,  
Jessica Navarro

**Dear Santa,**  
I want a computer and a tactoodol's and some cloths' and some shoes and any doll and a strolling baby and a barbie car and a Phone and a sega and I want the Lion king and Little mermaid and Beauty and the beast.  
Love,  
Ruby Espinoza

**Dear Santa**  
I wote a barby for christmas. I wote a dolc. I wote a bere. I wote a hase.  
Love,  
Stephanie Enriquez

**Dear Santa**  
I hop you get me a bike. and a paragr that ters ther hed i will tel you the name jason and tomac. and a pa gun ine gun. and a gamc that is a paragr game. I hope you ge me ol thes wut i wot santa. dier  
Love,  
Jacob Ruiz

**Dear Santa**  
Wood you ples bring me a barbie. And a saga with Sonick the heghod. And a gameboy. Wood you ples bring a calnder for 1995. And a pir of skis.  
Love,  
Hayli Wise

**Dear Santa,**  
I wot a bike fore christns. I wot a pararjar and a sagus game. my mom was nis two. my dad was nis a lot. my dad wrke hrd he this to make a lot uv mney. my uckow was nis too.  
Love,  
Julian Ortiz

**Dear Santa Claus,**  
We are in Kindergarten at Richardson Elementary School. We are trying to be good this year.  
Genaro wants a ball and a toy car. Alfredo wants a toy car and a toy horse. Marisela wants a doll and a ball. Yadira wants a doll and a red bike. Omar wants a toy car and a ball. Edith wants a red bike and a teddy bear. Arthur wants a book and candy. Angelica wants a toy car and a doll. Dario wants a toy car and candies. Juan wants a toy police car and new colors. Isidro wants a toy motorcycle and a toy car. Victoria wants a pink bike and a doll. Gerardo wants a ball and candy. Manaurc wants a toy car and a ball.  
Thank you for our gifts. We love you Santa. Bye—  
Mrs. Turner's and Mrs. Espinosa's class

**Dear Santa,**  
Please bring me a Barbie Car with a new barbie doll. I also want a dog toy that barks, and a Jasmine doll. I want a pink Power Ranger toy. I really want my own cassette player with a lion king book and a lion king cassette, and a coloring book Bring mom some flowers. Merry Christmas Santa.  
Thank you,  
Sasha Garza



**HALLELUJAH!**  
We'd like to join you and your family in celebrating this most holy occasion.

**Castro County Pump Co.**

**YULETIDE WISHES**  
May you and yours celebrate a holiday of great warmth and joy. And may you be blessed with good health and happiness always!

**Dimmitt Veterinary Clinic & Supply**

**CATCH THE SPIRIT!**  
Christmas is in the air and with it we extend our warmest wishes for a happy and healthy holiday season.

**MARIA'S**  
"A NEW EXPERIENCE IN MEXICAN FOOD"



**A Very Merry Christmas to You and Yours from Deaf Smith Electric Cooperative**

- |                  |                  |                 |                |
|------------------|------------------|-----------------|----------------|
| Wayne Thatcher   | Dan Higgins      | Tony Acker      | Tom Dickerson  |
| Sam Garrison     | David Spain      | Duane Artho     | Robert Scott   |
| Steve Horrell    | Helen Noyes      | Dorothy Bell    | Marion Carter  |
| Wendol Christian | Larry Pennington | Garlan McNutt   | Greg Goyne     |
| Mike Bridges     | Lloyd Crume      | Joe Kerr        | Bruce Johnson  |
| Steve Landers    | Mike Veazey      | Garre Lowrance  | Clark Andrews  |
| Tommie Weemes    | Pat Scott        | Eva Romo        | Ed Vaught      |
| Mike Wilson      | Ed Hartley       | Jerry Deckard   | Don Rieves     |
| Ronnie Brown     | Dean Reinart     | Sandra Thomas   | Paula Welty    |
| Steve Louder     | Wayne Lady       | Nick Yosten     | Justin McNeely |
| Terry Hudson     | Gene George      | Sammy Davison   | George Bullard |
| Larry McNutt     | Donald Wright    | Jerry Koenig    | Jimmy Holmes   |
| Harold Finch     | Carolyn Hund     | Shirley Murray  | Jerry Roberts  |
| Sandi Blevins    | Jimmie Rose      | Clarence Martin | Bonnie Carlson |
| Randy Laing      | Ramon DeLa Cerda | Bryan McGaw     |                |

**We're Making A List!**

... of our friends and customers we'd like to wish a very Merry Christmas. And you are right at the top!

**SANTA GRAM**

**Dr. Lee and Darla Baggett**



# LOTS of a and and



**Dear Santa**  
I whont a powerranger. wen it christmas I wtot a powerranger. on December I went to jason house I gave him a perzet. dear santa I like yor reindeers.  
Love  
Gregory Calderon

**Dear Santa**  
How are you. This year I want a white Power Ranger and a bike. I will give you some cookies and milk.  
Love,  
Skyler Smothermon

**Dear Santa,**  
all I want for chrismus is a barbi car with barbies. I want a lot of cat's and a I been good and I missed you hope you come and leave what I told you.  
Love your friend,  
BRENDA RAMIREZ

**Dear Santa,**  
How is Rudof in the randears? Ts it snoweng at the North Pole? Are you rade for Christmas Santa? i have my Christmas tree up today. I wtot a computer for Christmas Santa. I will gev you cookes Santa win you cum at nit. I will go to slep Santa.  
Love,  
CLARISSA HERRERA

**Dear Santa,**  
I wtit to go at The north pole. Hol Hol Merry Christmas. I Love Santa claus. Is your reindeer flying Santa Claus? I want a Barbe car. I want a Barde doll. I want a Barde Swimming pool Thank you.  
Love,  
ESTER VELASQUEZ

**Dear Santa,**  
I wtot fr Christmas a Sagu. I wtot a toya wadir. I wtot a gamger. I wtot a Sootpteno. I wtot a big bed. I wtot a sled. I wtot a toya Santa. I wtot a pet. I wtot a toya cor. I wtot a thee to i decorations.  
Love,  
ELIAS PORRAS

**Dear Santa**  
i luv santicloz i hop you brig los uv twoyz to ol uv us litou wuns plez wilou you bruigus twous  
From,  
Ricky Guerra

**Dear Santa,**  
I would like for Christmas a little computer and hand watch and wish everyone a Happy Holiday, peace and love to my family.  
thanks you,  
Dana Sandoval

**Dear Santa,**  
I wished that I had the Power Rangers and that all my family got what they wanted. Thank you. Merry Christmas.  
Love,  
CALEB BARRIOS

**Dear Santa,**  
How is Mrs. Claus? Is she doing good helping you doing wrck with you and the elfs?  
How are the reindeers is it snowing and is the North Pole cowd? Pleez brng me sum playdo and a baby chekup and a meny cloit.  
Love,  
HALEY HEARD

**Dear Santa,**  
Hal is the els? Are they make toys? hal is Rudolph and the utrs radeerse? Are they playeen with Rudolph? can you bregg mi a vcr?  
Love,  
BIANCA TORRES

**Dear Santa,**  
Are you rdece for Chrismus Ev? Hlao are you Santa? wtot are the elbes doocn? I will lev you sum cookes and I will lev roodof a ccri? I wtot my tow frut teth and lbyay and a t.v. and a radeo and Temey tok.  
Love,  
SHAUNA NUTT

**Dear Santa**  
I wtot mi siz barbey. Santa Claus say hiy to Doner for. Me. I wtot the midey mrofen piwer wanger wote Kembrey the pink ranjer.  
Love  
Jennifer Fuentes.

**Dear Santa,**  
I try to be good so bring me these. I want a sega and four games to the sega. I want a gameboy and 1 game to the gameboy. I want a gamegear and 2 games to the game gear.  
Your pal,  
JORGE MARTINEZ

**Dear Santa,**  
How are you doing? I have been a good boy this year. Could you please bring me a white ranger, red ranger, black ranger, super nintendo, game-gear, motorcycle bike, trampoline and LA Lights in the front. When you come in I will leave you cookies and milk on the table for you. Have a safe ride.  
Love you Alwas  
JESSIE LARRA JR.  
5 yrs.

**Dear Santa,**  
How is Roodof? Is he Bad? Santa am I good are bad? Santa I wtot a saga genes, a Tv, a car, a biak, a vedo game, and a nut cracer, a red ranger robot, and a white ranger. My sister wonts a bobo with a gres, and her Name is bute with a red gres. I wtot a wagon a tate bare, I owes wonit a dog for My buhday. I wtot a baskit ball I lost My ball. I thot that I was gowing to git a red ranger what shang his hed.  
Love,  
FABIAN DIAZ

**Dear Santa,**  
I want a Seg a CD and a bike. I have mised you this year and I hope you come by my house this year. I have been pretty good but not real good. I hope you can bring the Seg a CD and a bike. I believe in you but other kids don't!  
Love,  
CASEY HARGROVE

**Dear Santa,**  
I have been a good kid. All I want for Christmas is a Nerf football and a Talkboy.  
Sincerely,  
CHRIS ENRIQUEZ

**dear Santa**  
I wtot a bore for Chrimas and a game boy, and a litte mraed toy and Clre baer. and a doll and a tv and a pars raer. and a jrem bore and my sais bore.  
Love  
Sarah Lopez

**Dear Santa,**  
I have been a good boy this year and here are a few things I would like this year. I'd lik a ninja turtle, skates, and a bike. I'm not asking for a whole lot. I hope I can get one of these gifts. Love you Santa.  
VICTOR ORTIZ

**Dear Santa,**  
I have been good this year here is what I want!!! My size wedding Barbie, Exersize Barbie, stuffed Santa, shirt with L/Britnany Alane Heard on it, Angel, stuffed puppy, stuffed Rudolph.  
Love,  
BRITTANY HEARD

**Dear Santa,**  
Hao is mis claus is she doing fin? Haw is rudolph is his nos red? Is it snowing in the north pole? I like a gam boy. I like a bredol. I wtot a new car. I wtot a new christmas tree.  
Love,  
KENDRA SMITH

**Dear Santa,**  
I would like a My Size Wedding Barbie and a McDonald'Barbie.  
CELENA GREGORY

**Dear Santa,**  
I would like a bike and some Barbie stuff.  
KAYLA SAENZ

**Dear Santa,**  
I wtot a brobby four chrismus and a brobbycar and i wtot toys and a traen and a boll.  
From,  
Alexis Rodriguez

**Dear Santa,**  
I wish for liyin and I wish for a Dol. I wish for a Ber. and I wish for a jaclan. and I wish for a Bore. and I wish for a elfit. and I wish for a Bol. and I wish a than. and I wish for a jraf.  
From,  
Olivia Galindo

**Dear Santa,**  
I have been a very good boy and I would like Star wars, Jurassic Park and Power Rangers for Christmas. We love you. Merry Christmas. Say Hello to Rudolph.  
BRYCE PARKER

**Dear Santa,**  
I bin so nisse and will you plesse git me a priranjr it is the white rajre and plesse bring me a go cort and noo shooss.  
Love,  
Bryan Hall

**Dear Santa,**  
I hope Rudolph is nise is he nise Santa Claus tel wen I give you the letter. I want a sagou for my present. And a mordesikbike for my present. And one more thing I want 100 dolers.  
Love,  
MARK MELENDEZ

**Dear Santa,**  
How is Mers. Ciaus and how is the eivs? I hope they hav a nis Christmas. And I want a pinballgame and a bike and I want a basketballgoll and a new dog.  
Your frid,  
RYAN

**Dear Santa,**  
I would like a Teddy Bear and an exercise Barbie.  
YVETTE ARCE

**Dear Santa,**  
Please give the the following: a Type II Phaser, a Gallimimus, and a BB gun, and an Alien vs. Predator two pack. Thank you very much.  
Sincerely,  
TYLER MYA'IT

**Dear Santa,**  
I like your reindeers. Haw ore you and mis kclor hay ore, yol dooing. wood yol bring me a tll set and a modersill and a bisikell.  
Love,  
TUCKER SELF

**Dear Santa,**  
Ho is all the randears? The cvls arc they making toys for all uv my oh class? is the North-Pole coold? How is Ms-Claus doing is she doing finec? I wtot a barby car and a radaer toy. Merry Christmas Santa-Claus.  
Love,  
NATASHA RODRIGUEZ

**Dear Santa,**  
My name is Laura Raser. How are you and Mrs Claus? Is It cold at the North pole? are your elfs making presents? How are your reindeers? Are you redy foor Christmas? My brather wuts A truck. My fravrat coror is blue. I like games to play. Do you like your reindeers? I like christmas. Do you like Christmas? Do you like roodoff? Do you like roodoffs nose? I do. I like Dolls. Do you? I like games. Do you? Do you like Christmas thank ubalt what It wood be like.  
Love,  
LAURA RASOR

**Dear Santa,**  
How is Rudolph? how is lfsv? Ples Santa, I wtot a saga white powr rangr.  
Love,  
BOBBY PRIETO

**Dear Santa,**  
I would like a My Size Wedding Barbie and a McDonald'Barbie.  
CELENA GREGORY

**Dear Santa,**  
I would like a bike and some Barbie stuff.  
KAYLA SAENZ

**Dear Santa,**  
I hope Rudolph is nise is he nise Santa Claus tel wen I give you the letter. I want a sagou for my present. And a mordesikbike for my present. And one more thing I want 100 dolers.  
Love,  
MARK MELENDEZ

**Dear Santa,**  
How is Mers. Ciaus and how is the eivs? I hope they hav a nis Christmas. And I want a pinballgame and a bike and I want a basketballgoll and a new dog.  
Your frid,  
RYAN

**Dear Santa,**  
I like your reindeers. Haw ore you and mis kclor hay ore, yol dooing. wood yol bring me a tll set and a modersill and a bisikell.  
Love,  
TUCKER SELF

**Dear Santa,**  
Ho is all the randears? The cvls arc they making toys for all uv my oh class? is the North-Pole coold? How is Ms-Claus doing is she doing finec? I wtot a barby car and a radaer toy. Merry Christmas Santa-Claus.  
Love,  
NATASHA RODRIGUEZ

**Dear Santa,**  
My name is Laura Raser. How are you and Mrs Claus? Is It cold at the North pole? are your elfs making presents? How are your reindeers? Are you redy foor Christmas? My brather wuts A truck. My fravrat coror is blue. I like games to play. Do you like your reindeers? I like christmas. Do you like Christmas? Do you like roodoff? Do you like roodoffs nose? I do. I like Dolls. Do you? I like games. Do you? Do you like Christmas thank ubalt what It wood be like.  
Love,  
LAURA RASOR

**Dear Santa,**  
How is Rudolph? how is lfsv? Ples Santa, I wtot a saga white powr rangr.  
Love,  
BOBBY PRIETO



**Dear Santa,**  
I hope Rudolph is nise is he nise Santa Claus tel wen I give you the letter. I want a sagou for my present. And a mordesikbike for my present. And one more thing I want 100 dolers.  
Love,  
MARK MELENDEZ

**Dear Santa,**  
How is Mers. Ciaus and how is the eivs? I hope they hav a nis Christmas. And I want a pinballgame and a bike and I want a basketballgoll and a new dog.  
Your frid,  
RYAN

**Dear Santa,**  
I like your reindeers. Haw ore you and mis kclor hay ore, yol dooing. wood yol bring me a tll set and a modersill and a bisikell.  
Love,  
TUCKER SELF

**Dear Santa,**  
Ho is all the randears? The cvls arc they making toys for all uv my oh class? is the North-Pole coold? How is Ms-Claus doing is she doing finec? I wtot a barby car and a radaer toy. Merry Christmas Santa-Claus.  
Love,  
NATASHA RODRIGUEZ

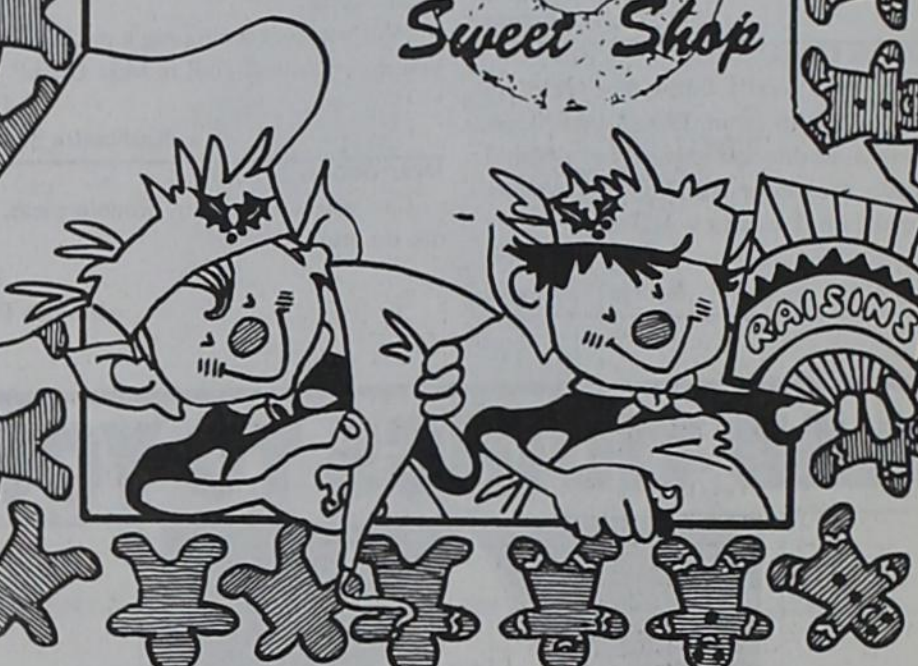
WE'RE AT YOUR  
"Bake" and  
Call...   
to sweeten up your holidays... and everyday. Many thanks for your delectable patronage.  
TROY'S  
Sweet Shop  
Larry, Annette, Rosie & Christina

*With Warm Wishes  
From The Whole Flock  
We appreciate having you as our customers.*

**C&T  
Fertilizer,  
Inc.**

Just In The "Nick"  
Of Time!



Our very best wishes are on the way.  
Thanks for your business -- have a great holiday!

**Baker Electric Services**  
James Baker  
647-2623 (home) or 647-6964 (mobile)



Warmest wishes  
for the happiest  
of holiday seasons.

**Dimmitt  
Consumers**  
217 E. Bedford • 647-4134

**HAVE  
A  
SPECIAL  
CHRISTMAS**

The tree has been trimmed, the gifts taken care of, the halls have been decked. The only thing left to do is wish all our friends the best Christmas yet!

**KDHN  
1470**



...ON  
**CHRISTMAS!**

Hope your season takes off with a flourish of good cheer and lands you some terrific gifts!  
We could not have gotten our business off the ground without you!

**Holly Sugar Corp.**  
Hereford





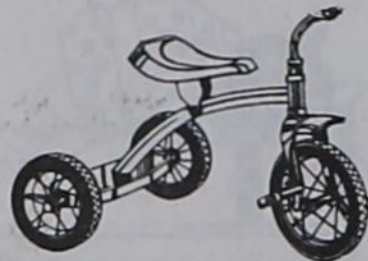
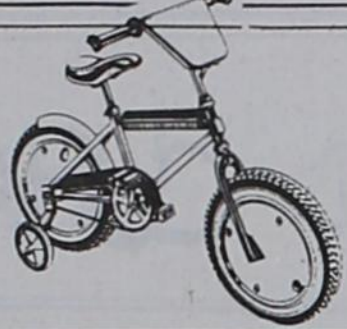

and

**Dear Santa,**  
I have been helping my mom clean dishes all year. I help my dad wash the car. For Christmas I would like a white ranger and a IBM computer and a power ranger with a cover on it. Have a safe trip and nice time.  
Aaron Herrera

**Dear Santa,**  
I want a Nintendo game and a white ranger, and a computer and a power ranger game, and a big Christmas tree with white balls on it. I will be in Dimmitt with my Grandma and Grandpa and Aunt.  
Love,  
Daniel Perez

**Dear Santa,**  
I have been a good Boy This year. I help my mom mow the lawn and take out the trash. I would like a math book, Bingo game, and a clue Jr. Game, and a compwtor and a sagoga jensis. thnk you have a good trip  
Joshua McAlister

**Dear santa**  
please come to my house this Christmas. I want a dog, Barbie jeep a real pink rabbit and a computer. I make beds at home to help mama.  
Love,  
Amber Enriquez

**Dear Santa Claus,**  
How is Mrs. Claus Has she been baking cookies? for Christmas I want a computer, skates and a coloring book. I will be home at Christmas I hope you come to see me.  
Love,  
Nicole Tarango

**Dear santa.**  
I want a santa Claus like you I want a computer. I want a bike and a motor jeep I fix my bed and I help my mom clean the rooms.  
Love,  
Angel Diaz

**Dear Santa Claus,**  
I want a remote Barbie and a little play dog. I will be home in Waco for Christmas at Grandmas and Grandpas.  
Love,  
Tabitha Sullivan

**Dear Santa Claus,**  
I Want a makeup beauty for Christmas. I want a little Kitten also. I help clean my room and do The dishes. I also want a doll.  
Love,  
Marisa Allison

**Dear Santa,**  
I want a Harlis Davis bike and it got a blk thing what Harlis Davis got on his motorcycle. And I want a power range game for my Super Nintendo to play with.  
Love  
Gerald Thomas

**Dear Santa,**  
I love you. Please bring me everything I asked for.  
Love you,  
Megan Wilkerson

**Dear Santa Claus,**  
I have been good I throw The trash for my mom and help clean. Would you please bring me a Barbie car compwtor a bear I Will have cookies and milkl. I also want some make up. I want a watch too.  
Love,  
Bridge Velasquez

**Dear Santa,**  
Will you ples bring me a prezn? Hall ara you do you doin? Hall is Miss Claus?  
Luvu,  
Kashondra Sherman



**Dear Santa,**  
How are your reindeer? I have been good. Would you please bring me some rollerblades, a purple jam box and a game called Lite Brite. I collect glass bluebirds and I would like to have one. I will leave you some milk and Christmas cookies. Get lots of rest and have a safe trip.  
Love,  
Shayla Kenworthy

**Dear Santa,**  
I would like a new Bike, Barbie, a purse, a little radio, clothes, trampoline, and a Backpack for me. And I would like a T.V. and VCR. for the whole family, and a sega for my 3 brothers. I was trying to be a good girl.  
Your friend  
Mary Ellen Sanchez

**Dear Santa,**  
I would like to have a shirt that has my name on it. I really would like a pair of rollerblades and a fort.  
Love,  
Alicia D'nia Heard

**Dear Santa,**  
I would like to get a Barbie House, Barbies, stuffed animals and some new clothes. I would also like a Christmas doll and a bike.  
Samantha Howell

*May You Find Enlightenment*

Just as the eastern star shone for the wise men on that very first Christmas, may you be guided to love and peace this holiday season.

**George's Exxon Station**

**GLAD TIDINGS TO YOU!**

Hope your season is a perfect "10"!

**THE HEADHUNTER**

**Dear Santa,**  
I wanted to see how you wr feeling. just hope you wile like Christmas. If I have sm Chrmas cukes and pies you can hav sum. Breg my A dol.  
luve,  
Ivy Sanchez

**Dear Santa,**  
I want rings and some play plantes and a computer and shoes, bow, and a skirt to go with a cowgirl shirt.  
Thank you,  
Adriana Arcos

**Dear Santa Claus,**  
I hope that you wud cum ot miye hous that wud be sum koocess and milk plesse brengre me a barbiecor.  
Luve  
Rocio Rodriguez

**Dear Santa,**  
I am in Head Start. Mrs. Lynn is my teacher. This is what I would like for Christmas. Please remember all the kids all over the world. We have all been good.  
Veronica Martinez wants a Bride Barbie.  
Mayra Olivas wants a Dance Barbie.  
Erika Aguilar wants a Dance Barbie.  
Adriana Jaramillo wants a Bride Barbie.  
Annia Lopez wants Evening Barbie.  
Daniella Neri wants a Barbie House and a Bride Barbie and her car.  
Cynthia Gomez wants a Barbie House and Indian Princess Barbie.  
Cecilia Ornelas wants a Dance and Twirl Barbie.  
Patricia Quintana wants a Barbie Doll and house.  
Gloriela Ontiveros wants a Barbie bed and Dancing Barbie.  
Anna Reyes wants a Night Dazzle Barbie.  
Max Sandoval Jr. wants a Power Ranger Assault Team and Robo Cop.  
Jesus Sanchez wants Thunder Ultrazod.  
Jorge Robles wants a fire truck and a racing set.  
Thank you!

**Dear Santa,**  
Pleas bring me a white Power Ranger. But a big white PowerRanger that moovs his leg too the rite and left side. But not a stufft wun a metel wun weth pads and sum uthers.  
Love,  
JJ Pena

**Dear Santa,**  
I am in Head Start. Mrs. Lynn is my teacher. This is what I would like for Christmas. Please remember all the kids all over the world. We have all been good.  
Veronica Martinez wants a Bride Barbie.  
Mayra Olivas wants a Dance Barbie.  
Erika Aguilar wants a Dance Barbie.  
Adriana Jaramillo wants a Bride Barbie.  
Annia Lopez wants Evening Barbie.  
Daniella Neri wants a Barbie House and a Bride Barbie and her car.  
Cynthia Gomez wants a Barbie House and Indian Princess Barbie.  
Cecilia Ornelas wants a Dance and Twirl Barbie.  
Patricia Quintana wants a Barbie Doll and house.  
Gloriela Ontiveros wants a Barbie bed and Dancing Barbie.  
Anna Reyes wants a Night Dazzle Barbie.  
Max Sandoval Jr. wants a Power Ranger Assault Team and Robo Cop.  
Jesus Sanchez wants Thunder Ultrazod.  
Jorge Robles wants a fire truck and a racing set.  
Thank you!

**Dear Santa,**  
How is Mes Closs? Can you bring me a tiger sord? Dear Santa, will you bring me a Sobba?  
Luve,  
Emilio Mendoza

**Dear Santa,**  
I am in Head Start. Mrs. Lynn is my teacher. This is what I would like for Christmas. Please remember all the kids all over the world. We have all been good.  
Veronica Martinez wants a Bride Barbie.  
Mayra Olivas wants a Dance Barbie.  
Erika Aguilar wants a Dance Barbie.  
Adriana Jaramillo wants a Bride Barbie.  
Annia Lopez wants Evening Barbie.  
Daniella Neri wants a Barbie House and a Bride Barbie and her car.  
Cynthia Gomez wants a Barbie House and Indian Princess Barbie.  
Cecilia Ornelas wants a Dance and Twirl Barbie.  
Patricia Quintana wants a Barbie Doll and house.  
Gloriela Ontiveros wants a Barbie bed and Dancing Barbie.  
Anna Reyes wants a Night Dazzle Barbie.  
Max Sandoval Jr. wants a Power Ranger Assault Team and Robo Cop.  
Jesus Sanchez wants Thunder Ultrazod.  
Jorge Robles wants a fire truck and a racing set.  
Thank you!

**Dear Santa,**  
How are you doon on Christmas? I bin gur for a pouer Ranjnr. Will you cum to mi hous frerst?  
Love,  
Casey Maurer

**Dear Santa,**  
I am in Head Start. Mrs. Lynn is my teacher. This is what I would like for Christmas. Please remember all the kids all over the world. We have all been good.  
Veronica Martinez wants a Bride Barbie.  
Mayra Olivas wants a Dance Barbie.  
Erika Aguilar wants a Dance Barbie.  
Adriana Jaramillo wants a Bride Barbie.  
Annia Lopez wants Evening Barbie.  
Daniella Neri wants a Barbie House and a Bride Barbie and her car.  
Cynthia Gomez wants a Barbie House and Indian Princess Barbie.  
Cecilia Ornelas wants a Dance and Twirl Barbie.  
Patricia Quintana wants a Barbie Doll and house.  
Gloriela Ontiveros wants a Barbie bed and Dancing Barbie.  
Anna Reyes wants a Night Dazzle Barbie.  
Max Sandoval Jr. wants a Power Ranger Assault Team and Robo Cop.  
Jesus Sanchez wants Thunder Ultrazod.  
Jorge Robles wants a fire truck and a racing set.  
Thank you!

**Dear Santa,**  
Please bring me Bicycle Barbie and some Barbie clothes. Please bring Adam some Cool Tools. We have been good.  
Love,  
Lana

**Dear Santa,**  
Please bring me a little water baby, a barbie doll house, some play food for my kitchen, a thermos for my bike, and a McDonalds cookiemaker.  
Love,  
Robin Beames

**Dear Santa,**  
I would like some Hockey sticks, pup, Roller Blades, pads, Hclmet, and a go cart. and Steel Tec.  
I want you to wake me up and I want you to take me on a sleigh ride and I want you to help put out the toys at the houses and let me see Rudolph with the shiny nose!  
I am going to sleep in my living room. Santa, be sure to wake me up.  
Houston Sutton

**Dear Santa,**  
I am in Head Start. Mrs. Lynn is my teacher. This is what I would like for Christmas. Please remember all the kids all over the world. We have all been good.  
Veronica Martinez wants a Bride Barbie.  
Mayra Olivas wants a Dance Barbie.  
Erika Aguilar wants a Dance Barbie.  
Adriana Jaramillo wants a Bride Barbie.  
Annia Lopez wants Evening Barbie.  
Daniella Neri wants a Barbie House and a Bride Barbie and her car.  
Cynthia Gomez wants a Barbie House and Indian Princess Barbie.  
Cecilia Ornelas wants a Dance and Twirl Barbie.  
Patricia Quintana wants a Barbie Doll and house.  
Gloriela Ontiveros wants a Barbie bed and Dancing Barbie.  
Anna Reyes wants a Night Dazzle Barbie.  
Max Sandoval Jr. wants a Power Ranger Assault Team and Robo Cop.  
Jesus Sanchez wants Thunder Ultrazod.  
Jorge Robles wants a fire truck and a racing set.  
Thank you!

**Dear Santa,**  
I am excited about Christmas. I know that you are watching. I have been good this year. For Christmas I would like a Power Ranger bike and a back pack. Please be sure to leave a gift for every boy and girl around the world. I will leave milk and cookies for you.  
What kind of Jell-o do you like?  
Your friend,  
Dino Diaz

**Dear Santa,**  
I am in Head Start. Mrs. Lynn is my teacher. This is what I would like for Christmas. Please remember all the kids all over the world. We have all been good.  
Veronica Martinez wants a Bride Barbie.  
Mayra Olivas wants a Dance Barbie.  
Erika Aguilar wants a Dance Barbie.  
Adriana Jaramillo wants a Bride Barbie.  
Annia Lopez wants Evening Barbie.  
Daniella Neri wants a Barbie House and a Bride Barbie and her car.  
Cynthia Gomez wants a Barbie House and Indian Princess Barbie.  
Cecilia Ornelas wants a Dance and Twirl Barbie.  
Patricia Quintana wants a Barbie Doll and house.  
Gloriela Ontiveros wants a Barbie bed and Dancing Barbie.  
Anna Reyes wants a Night Dazzle Barbie.  
Max Sandoval Jr. wants a Power Ranger Assault Team and Robo Cop.  
Jesus Sanchez wants Thunder Ultrazod.  
Jorge Robles wants a fire truck and a racing set.  
Thank you!

JOY TO THE WORLD!

To all our valued customers we offer our gratitude and good wishes for a happy holiday season.

**EARL'S GARAGE**

**Merry Christmas!**

We've gathered round to thank you for your valued patronage. Have a joyous holiday season!

**Cluck Feed Yard**

*May God Bless Your Home This Holiday Season*

Wherever you live, may you be visited by faith, love and good fortune in the year to come. We feel blessed to have so many good customers and friends. Thank you for visiting us.

**Westway Trading Corp.**  
Fred Bruegel, Manager  
N. Hwy. 385

**Thank's**

May your Christmas tree be filled with garlands of love, bells of hope, tinsels of charity, and wreaths of wonder. Happy Christmas.

**Gary's Engine & Machine**





Dear Santa,  
Hi. I would like you to bring me a barbie the same size as me. I would also like a pink ranger. If you could also remember a barbie that does upside down splits. I would like a flintstones T-shirt.

Thank you,  
Daniela Zepeda

Dear Santa,  
I am 6 years old. Please bring me a saw, slide, K-nex and an hourglass. I have been a good boy.

I love you,  
Zane Matthews

Dear Santa,  
I have been a good girl. I want you to bring me a barbie, doll, and a Barbie doll house, for Christmas. I also want you to bring my Uncle Tonto and Aunt Terrie home for Christmas.

I Love You  
Jayme D'Kasey Flores

Dear Santa,  
I want a white Power Ranger and a bike. I will leave you milk and cookies.

Love,  
Joshua Smothermon

Dear Santa,  
Will you please bring me a remote control barbie with Ken, a learning computer, and a pink and white toy box. Also, I want a stuffed animal of you and one of your elves.

I love you Santa,  
Joslyn Hammonson

Dear Santa,  
Hi, my name is Vikki Sanchez my address 406 W. Andrews. My list is long but here it goes. First of all I want a Barbie doll and swimming pool, and a Bed, a pink power ranger, Lion King. For my baby sister I would like a little pink power rower, for my little brother a Tonka Truck, for my dog Duce a play dog, For my aunt Christy a Mickey Mouse shirt, and finally my dad a tool box

Your friend  
Vikki Sanchez

Dear Santa,  
I want for Christmas Barbie House, Horsing Barbie, Walkmen to, lips set, and make up set, pink bike, sleeping barbie, Radio and 10 cassettes.

I love you Santa.

Love,  
Kim

Dear Santa,  
I want a tractor and toolbox. I also want an ice cream maker from McDonalds. I Love You, Santa. I would like to come see you and ride in your sleigh. I don't know if you will let me ride in your sleigh.

Kalan Dean Steinle

Dear Santa,  
I want Lion King and a puppy. a doll that talks

Valeria

Dear Santa,  
how is Rudolph, Dasher, Pranser, vicksin, Danser, Blisin. I don't know the other 2 Reindeers. Tell Miss. Santa Mary Christmas tell the Reindeers Mary Christmas. I hope you got lots of stuff for me. When You leaf the first houses you go to might be my houses. Is Rudolph a good reindeer. I hope so. How are the Elves doing tell the Elves Mary Christmas. I might rite to you Dear Santa.

Samantha

Dear Santa  
I want a skate broad, Power Ranger, and a game for my Super Nintendo, toys for my brother and sister.

Love,  
Matthew Almaanza

Dear Santa,  
i want a sega with the lion King pack. and a remot centro robot. and a cusit of tag team and some gi joes. And a football hellmen of Dalls cowboys. And some cloths. and a play pulet gun. And a dart bord and Darts. and a pinball master. i want a hand hell game.

Adam Mendoza

Dear Santa,  
I would like a white power ranger, a nintendo game, a sword, and have a nice Christmas.

Thank you  
Robert

Santa Claus and Reindeer  
Juan B. Camacho loves you Santa and Reindeer He loves you. Jesus. R. Rodriguez Loves you santa to. I wan't you to give me a present and I will give you a present. o.k. from: Jesus R.R. J.B.C.

Dear Santa,  
I am in Ms. Soliz class. My name is Jared. I a goo citizen. I want a super NES. Mieceky Mania. All of the power rager. All of X-men.

Love,  
Corrie Kate Black

Dear Santa,  
Thank You for the toys you gave me last year. This year i would like a Power Ranger sword, a White Ranger suit, a Bunk bed. I have been a good boy. I will leave some cookies for you. What do reindeer like to eat?

Love,  
Sean Lookingbill

Dear Santa,  
I am in Mr. Solizes' second grade class. I have been a good citizen this year. Can I have a new barbie and a new nintendo Game. Marry Christmas.

Love,  
Kayla Acker

Dear Santa Claus,  
I have been good so I decied to let you know what I want. First I want a panda bear and a suit that has riendeer on it, plus a baby doll that talks. Since you're really nice I'll leave you and your riendeers a snack.

LOVE,  
Thelma P. Medrano

Dear Santa,  
My name is Andy Garcia I am in Mr. Soliz class secong grade I have been a good citizen. I want a Ricochet for x-mas and a pet mouse for x-mas.

Love,  
Andy Garcia

Dear Santa  
I like you very much Santa Claus I have been a good little boy won't u give me a bike. And white ranger tiger, a tool set, And i want a bat and ball. Please bring my baby sister Alyssa a barbie set I almost Forgot to tell you I want a sega genesis.

Love Always  
Eric Saenz

Dear Santa,  
I am in Mr. Soliz' second grade class. I have been a good student. I want a power wheels. I want a computer. I want a baby that crys. I want a barbie that is called My Size barbie.

Nayelli Reyes

To Santa  
I want all these things for Christmas, a car, truck and a bike.

Love you Santa  
From Juan R. Camacho III

Dear Santa,  
I am in Mr. Soliz' second grade class. I have been a good Citizien. I wanta bike a Harly Davidson sega computer.

Love,,  
Shan



Dear Santa,  
I have been a pretty good girl this year. Thank you for the desk. This year I would like a Tv and a telephone. I will leave you a treat.

Love,  
Callen Mixson

Dear Santa,  
I want a cool splash hot pink bike. I want "don't wake Daddy," (Gator golf), "Hot shot," "Loopin Louie" Slobbery sam, "Crocodile Dentist. I want "Monkey Trouble," the movie, "Black Beauty," One golfen glove. A couple of Christmas decorations!

Love,  
Shelley Paxton

Dear Santa,  
I would like to have 5 bikes one for me and the other's one for my brothers and one for my sister. These are how old there are 4 boys 47810 1 girl 9 and a sega nintendo and the power ranger game with it power ranger game toy a dallas cowboys hat pencil and plesse bring me these things to me and my brothers and my sister.

Love,  
Raul Dones

Dear Santa,  
My name is Ashley Fleeks, I am 4 yrs. old. I live at 807 SW Sixth. I have been pretty good little girl this year. So will you please bring me these items for Christmas: Easy Bake oven, feeding baby doll, clothes, talking shoes cassette player, and the program You Can Read. I am in Pre K. Mrs. Robertson is my teacher. Santa, please, bring my brothers something for Christmas and all my friends something too Santa. Santa don't forget my mother and father. I love them very much. Santa, we will leave you some egg nog and cookies.

Love,  
Ashley Fleeks

Dear Santa,  
I hope that you could bring me this presents this year! I want my size barbie, camping barbie, earrings, rings, dress, a doll, a neckles, some shoes, shirt, trolls, and a happy family.

Love,  
Andrea Ortiz

★ HOPE YOUR SEASON IS Heavenly! ★

*It's been a privilege and a pleasure to serve you this past year.*

**Clip 'n Curl Beauty Shop**  
**Running M Boot & Bath Shop**  
**The Feed Bin**  
**Custom Cleaners**

★



**MAY YOUR HOLIDAYS SUIT YOU!**

We'd be really hard-pressed to find customers more wonderful than you. Thanks so much for your valued patronage.

**Alvin's Drive-In Cleaners**

**Wishing You A Tasteful Season!**

*Holiday Menu*  
Seasonal Soups  
Soup du Joy  
Creme de Cooer  
Extra Fine Wishes  
Fresh Goodwill  
Warm Requests A la gel Hic

To our many fine customers, we're serving up our very best holiday wishes. Thank you for dining with us this year.

**Pancake House**

Wishing You A Heavenly Holiday

Thank you for blessing us with the gift of your friendship.

**Circle M Irrigation, Inc.**

**Merry Christmas**

\* Mrs. M.L. Simpson, Jr., County Judge \* CD Fitzgearld, Sheriff  
\* Jerry Matthews, District/County Attorney \* Oleta Raper, County Treasurer  
\* Maretta Smithson, County Auditor \* Marshall Young, Justice of the Peace  
\* Joy Jones, District/County Clerk \* James Dobbs, Constable \* John Alldredge, County Surveyor  
\* Billy Hackleman, County Tax Assessor & Collector \* Newlon Rowland, Pct. 1 Commissioner  
\* Dale Winders, Pct. 2 Commissioner \* Bay Baldrige, Pct. 3 Commissioner  
\* Vincent Guggemos, Pct. 4 Commissioner





**Dear Santa**  
I want a gan to play at I wont a bed for i kud slep on the bed I want toys for I kud I wat a bareca play with My bes frend love,  
Jessica Pcna

**Dear Santa**  
I want a bike.  
I want a barby.  
I want a toyying  
I want a barby skan  
Love  
Valeric Ledesma

**Dear Santa**  
How are old. I want a football. I want gev my sistr a barbys. How are you dong? How are you mdris?  
Love,  
Louis

**Dear Santa,**  
How are you? Are you coming to our house? I wish I can see you. When you get to my house wake me up. I wish for a little T.V. with a V.C.R., a remote control, a basketball, a game that is called Monopoly, a Segh Genesis and some ProRolerBlades. I will leave you milk and Club Crackers. I have been very good.  
Love,  
AMANDA

**Dear Santa,**  
I want a big screen T.V., and a ball to play tennis and a net and a Super Nintendo with five games, I want a pin like Amanda.  
Love,  
MARIZA  
Thank you.

**Dear Santa,**  
I wish for a Super Nintendo with four games and I wish for two game gears and four games, and a big trampoline only for me and my brother, and two glowing footballs for me and my brother, and ten dollars for me, and a glowing watch for th night, and a lionking tape so I could hear in the night and three beanbags.  
Love,  
FREDDY

**Dear Santa,**  
I am 7 years old. I would like a white Power Ranger toy, I would like a Red Dragon Sword. I would like for you to bring my sister a yellow Power Ranger.  
Your friend,  
RAMON PUGA

**Dear Santa,**  
I want a Nintendo and a set of a tea party, and also a computer and dishes and a Polly Pocket. I want a Sega and also a television and doll stretcher. Also I want a Genesis, darts, and a rabbit and a horse with a saddle.  
Your truly,  
Diane Bustos

**Dear Santa,**  
Could you please bring me a Power wheeler? I would also like a toy dinosaur, a drum with many clors, and a Bigfoot truck.  
yours truly,  
CHICO BARRON

**Dear Santa,**  
I would like a car that runs on batteries and a play gun. I would also like to have a train, a toy bus, and a monster truck.  
Your friend,  
Polo Fernandez



**JUST IN THE NICK OF TIME**  
...We're Sending Our Warm Wishes Your Way  
We didn't want to let another minute go by without letting you know how much we value your business.  
Merry Christmas!  
**Red X Travel Center**

**Dear Santa,**  
I want a bicycle and a monster truck and little truck to play with and a big monster so I can scare my nephew It is fun when I scare them. That's why I want them to come evrey day.  
Love, your friend  
Eric Ward

**Dear Santa,**  
I wish I had a Sega and a big story house. And I want a new car and a bike and a trampoline. I want a swing but most I wish I had four vacacstins.  
Your pal,  
Manuel

**Dear Santa,**  
All I want for Christmas is a bike or skates or kitty in my pokcet or talking simba or a game of Aladin or Simba. Get my brother a bike and get my sister a bike please.  
Your friend,  
Eva

**Dear Santa,**  
I want a mokon troll car and a nentendo and supper mororo brother and a basketball goal and ants in the pants and checkers and a talking robots.  
Your friend,  
Michael Ward

**Dear Santa,**  
I wish my mom and dad had some money to by us some toys. I wish I could see you and you could bring me toys. I wish you could send me a letter. I know you could bring me a Sega and some dishes. That's all Santa, and don't forget to send me a letter.  
Your friend,  
Moraima Romero

**Dear Santa,**  
For Christmas I would like a Mortal Combat for Game Gear. I would like a trantula, I would also like a goldfish because my sister thinks that I killed the other one. I woul like a four-wheeler and a stretchable Armstrong. If you can I would like a schnauzer. I hope I can see my dad more than I see him now. I would like a computer.  
Love,  
Isaias Ponce

**Dear Santa,**  
I hope you bring me my four-wheeler for Christmas and I hope you bring everybody what they want. I wonder how you make all those presents. I want a power rangers video game. I wonder how the elves get to the North Pole. I wonder how you got the reinder including Rudolph. I hope you have a wonderful Christmas.  
Your friend,  
Adam Pantoja



**With Heartfelt Thanks**  
We appreciate your friendship and support.  
Merry Christmas to one and all.  
**Nelson Well Service**

**a word from the wise:**  
**REJOICE!**  
May you and your family enjoy a Christmas filled with the gifts of His love.  
We appreciate the gift of your friendship.  
**TULIA LIVESTOCK AUCTION, INC.**

**Merry Christmas!**  
**Merry Christmas Happy Holidays Season's Greetings Joyous Noel**  
No matter how you say it, we hope your season is grand.  
We truly appreciate your kind patronage.  
**THRASHER'S Auto Sales**

**Greetings From the Santas**  
Along With Mr. & Mrs.,  
We Send You Lots Of Love & Kisses.  
Many thanks for your year-round support. Merry Christmas.  
**Hart of the Plains Pump, Inc.**

**JOY TO THE WORLD & PEACE ON EARTH!**

*In the true spirit of Christmas, we'd like to join together with people everywhere to pray for peace, brotherhood and understanding between the many nations that inhabit this small planet we all call home.*

*And to you, our dear customers, we hope that good cheer abounds. May there be plenty of love and joy to go around!*

*Thanks for your friendship this past year.*

We will be closed Sunday so our employees may enjoy Christmas with their families.

**IGA Foodliner**

**THRIFTWAY**



# A WORLD OF GOOD WISHES FROM HART, TEXAS!

*Christmas greetings from the "town with a heart." Instead of sending individual cards to our local friends, we have donated our card money to the Hart Cemetery Fund. It's a tradition which we feel honors the memory of those who helped make so many Christmases happy for all of us.*

- Harold Bob, Ruth, April and Shea Bennett
- Bob and Nancy Bowden
- Everette and Bea Cole
- Mrs. Harvey Davis
- Sue A. Dinwiddie
- Lloyd and Augusta Farris
- Joe Percy and Sarah Hart
- Doug and Marylyn Higgins
- Sandy and Chad Hill
- Nora Lancaster
- Bob and Deana McLain
- L.C. and Marguerite McLain
- Midge McLain
- Mrs. Orval Sharp

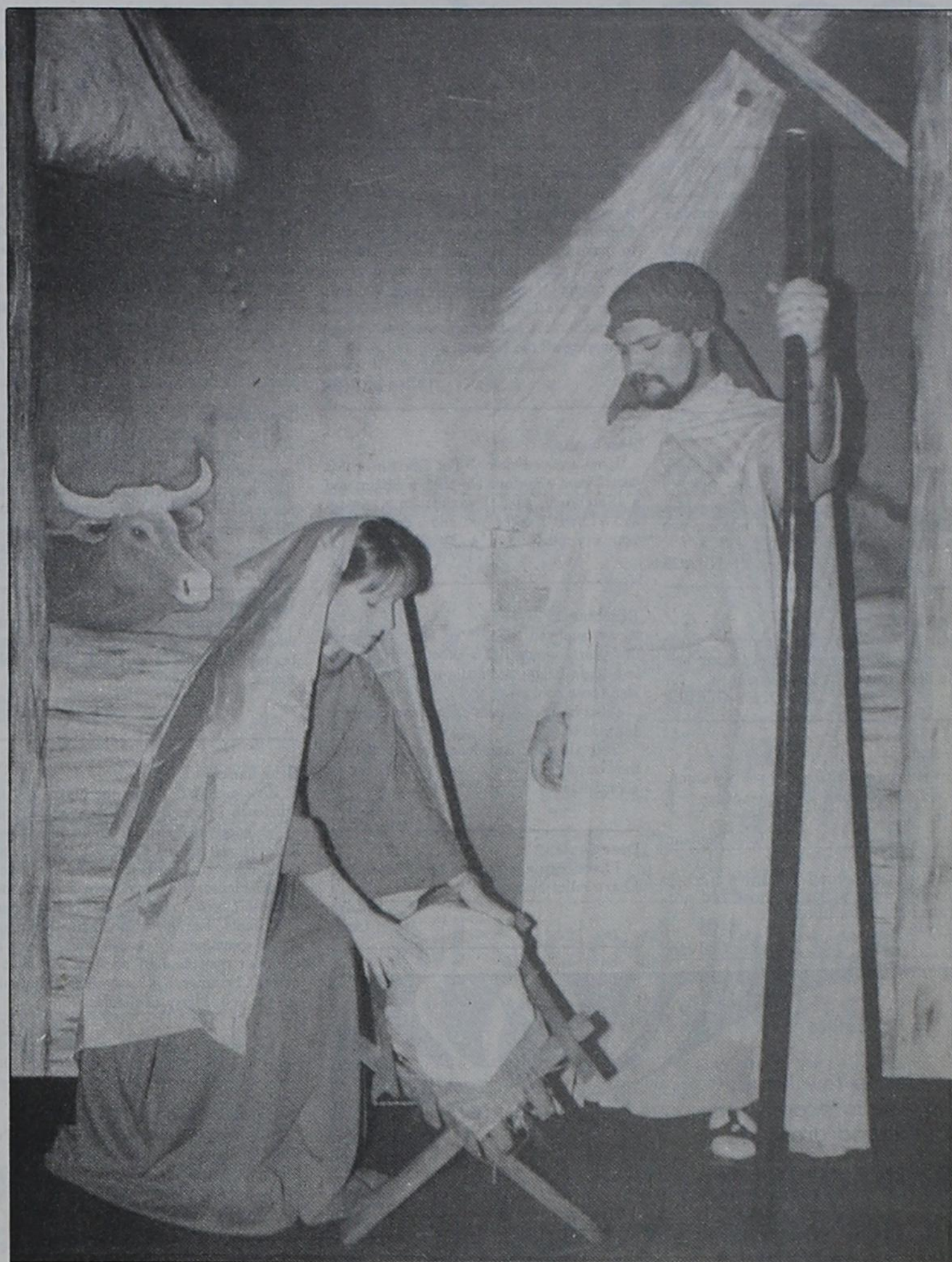

## Season's Greetings from Nazareth

*Christmas greetings from the community that's named for Christ's hometown. Instead of sending individual cards to our local friends, we have donated our card money to benefit the Holy Family Cemetery. We hope Christmas 1994 will be blessed and memorable for you!*

- Dwayne & Anne Acker & Family
- James & Pearl Acker
- Ralph & Evelyn Albracht
- Sam, Margie & Cindy Albracht
- Alvin, Matilda & Steve Anderle
- Evelyn Backus
- Helen Backus
- Hubert, Joan & Ron Backus
- Urban Ball
- Father Darryl Birkenfeld
- Greg, Glenda, Jason, Jaime & Matthew Birkenfeld
- Herman, Marilyn, Joel & Alan Birkenfeld
- Leonard & Julia Birkenfeld
- Margaret Birkenfeld
- Petronilla Birkenfeld
- Keith & Kim Birkenfeld & Family
- Louise Braddock
- Cecil & Lenora Braddock & Family
- Arnold & Katie Brockman
- Cyril & Miltz Brockman
- Dale, Mona, Scott, Marcus & Andrew Brockman
- Mr. and Mrs. Ernest Brockman
- The Jerome Brockman Family
- Ralph & Sharon Brockman & Family
- Duane, Nan & Cody Davis
- Rev. Neal Dee
- Brightta & Richard Dobmeyer
- Lucille Drerup
- Leo & Marian Durbin
- Gladys & Angela Fortenberry
- Dan, Karen, K'Lynn, Shawna & Clifford Gerber
- Fritz & Julene Gerber
- Joel, Mary Beth, Nicholas, Stephanie Lindsey, Erica & Alex Gerber
- Mick, Jane, Laura & Alan Gerber
- Mr. & Mrs. Tony Gerber
- Virgie & Keith Gerber
- Vincent & Toby Gerber & Boys
- The Leonard Gerber Family
- Vincent Guggemos & Dorothy
- Mary Beth, Gene, Jessica, Albert & Jason Haschke
- Denny & Dolores Helman
- May & Bernie Hochstein
- Cecil, Norita & Annette Hoelting
- Clyde & Bea Hoelting
- Greg & Tinnie Hoelting
- Jim & Sandee Hoelting & Family
- Keith, Karleen, Mandy, Brett & Kyle Hoelting
- Ronnie & Regina Hoelting
- Tom & Raelene Hoelting & Family
- Derwin & Vera Huseman & Family
- Dorothy Ann, David, Adrienne & Wesley Huseman
- Louis & Gln Huseman
- Martha Huseman
- Vincent & Bert Huseman
- Virgil, Dianne, Evan, Kendra & Caitlin Huseman
- The Arnold Huseman Family
- Joe & Jeanette Johnson & Family
- Marvin & Quentin Jones
- Jerry, Carol, B.J., Jessica & Susan Kern
- Bud & Rita Kern
- The Anne Kern Family
- Dennis, Patti, Matthew & Aaron Kern
- Alphonse, Viola, Brad & Monica Kielem
- Alvin, Dorothy, Lee, Chris & Lynette Kielem
- Carl Dean & Mary Kielem
- Doyle, Rosie, Shane & Holly Kielem
- Dwayne, Sheryl, Garrett, Karis & Kenley Kielem
- Joe Kielem
- John & Jennifer Kielem
- Lucy Leinen
- Al & Leona Maurer
- Theresa Rose & Michael Mullen
- J.C., Jocelyn, Jill, Colby, Amy & Daryl Pohlmeier
- Leroy & Dorothy Pohlmeier
- Phillip & Dora Pohlmeier
- Ed & Leola Ramaekers
- Henry & Linda Jo Ramaekers & Family
- Rex & Vera Ramaekers & Family
- Elma Schacher
- F.P. & Lucille Schacher
- Johnny & Norma Schacher
- Danny Schilling
- Kenneth Schilling
- Rodger & Edna Rae Schilling
- Walter & Anita Schilling
- Lawrence Schmucker
- Mr. and Mrs. Joe Schmucker & Janet
- The Dan Schmucker Family
- Jim, Bobbie, Michael, Robby, Tiffany & Jayme Schmucker
- Ray, Mary Lou, Natalie & Melinda Schmucker
- Aurella Schoenberger
- Clarence & Odellia Schulte
- Clyde, Lisa, Robin & Adam Schulte
- Easy Schulte
- Floyd, Dorothy, Leroy & Dana Schulte
- Gilbert & Dolly Schulte
- Martha Schulte
- Marvin & Darlene Schulte
- Mary Ann Schulte
- The Elmer Schulte Family
- Rev. Brendan Sherry
- Vic & Val Steffens
- Howard & Tammy Steffens
- David & Becky Steffens
- Mrs. Pete Steiert
- Meta Stork
- Ray & Mattie Swirczynski
- The Paul Venhaus Family
- Robert, Mary & David Verkamp
- Winifred Wagner
- Thelma Wethington
- Cecil, Shari & Robin Wilhelm
- Damian & Stacy Wilhelm
- Dean, Diana, Bob & Cassidy Wilhelm
- Henry, Connie, Jennifer, Brandon & Heath Wilhelm
- Lavern & Ronnie Wilhelm
- Leonard & Rose Mary Wilhelm
- Stephen, Mary Jean, Matthew, Megan & Amy Wilhelm
- Virgil & Carolyn Wilhelm, Jessica, Marcus & John
- John & Margaret Womack
- Lester, Eileen & Allsha Womack



# Dear Santa

Dear Santa,  
Will you please bring me a light up yo-yo and Treasure Rocks? Hope you get through delivering presents.  
Love,  
LACEY ACKER

Dear Santa,  
Please Bring me a light up keyboard and a Baby All Gone. I have Been good.  
Love,  
HEIDI RAMAEKERS

Dear Santa,  
I have been good. Will you please bring me some presents. I want a water Baby, a talking doll house tattedoes, and Stacy McDonald. How are you? We're making you cookies. I love you.  
CANDACE

Dear Santa,  
How is Rudolph? Santa can you please bring me a cotton stripper, truck, soccer ball, and a hockey stick? I love you.  
BRADLEY GERBER

Dear Santa  
How ar you santa Claus? I wat a worgun. How ar the rader? and wat a rucmot car.  
love  
John Medrano

Dear Santa  
How old are you? I want a barby. My sister want a barby. how old are the ranr? I want a bike.  
I Love you  
Jannette Galvan

Dear Santa,  
I have been good this month so far. How is your reindeer, expesaly Rudolph? For Christmas would you give me a 2000 beeds to make bracelets with, and I want Treasure Rocks? I realy cant think of anything els but the movie of Black Beauty and the little game of the Lion King. I hope Mrs. Claus doesn't have a cold. Hope you get through delivering all the present.  
Love,  
JENNA ACKER

Dear Santa,  
How are you doing? For Christmas this year I want a motorcycle bike, a Bbgun and a sKateboard. Also, I would like a gun set and a Power Ranger Suit and a desk. Thank you very much!  
CHRIS ACKER

Dear Santa,  
How have you been? I've been real good this year. I would like a skooter, Hop-a-roo, tent Light Bright and a Big toy Box. oh and also some cool tools.  
Also bring my pets sassy And Bubba a surprise to.  
Tell all your Reindeers to Get well so they can fly you to everyone's house. See ya soon Santa.  
DUSTIN

Dear Santa,  
I have been a very good boy. Please, may I have roller blades.  
Thanks,  
Corey

Dear Santa,  
I have been a very good girl this year. I'm sorry I missed you at Mitzi's house. For Christmas, please bring me a dazzle dazzle car, a tattoo doll, jewelry set with a case, some finger paint would be nice to.  
My brothers have been good most of the time too. Please don't forget stuff for them. Leave you some cookies out.  
Love  
KAYTLIN HUSEMAN

Dear Santa,  
I've been a good girl. I hope your doing O.K. I want a barby that has a horse. I want snow white and the seven Drawfs movie. A baby that does gymnastics. A microwave that has real food. I want a McDonalds real food. Please bring my two brothers something.  
Love  
JENNIFER

Dear Santa,  
For Christmas Summer wants a banana. I want a bike, Mom speacil birthday. Marcus boom box. Dad a day off. Lacey roller scates.  
Love  
CASSIE SANDERS

Dear Santa,  
How are Mrs. Claus, the elves, and the reindeers. I hope they are fine. I have tried to be good this year. I would like Power Rangers and Dallas Cowboys stuff. If you could bring a soccer ball I would like it very much. Please bring my mom a music box because I broke hers. My daddy likes coins and wants them for Christmas. Bring my sisters something if you can. Please bring all the poor peoples stuff so they can have a Merry Christmas. I'll leave cookies and milk out for you. Merry Christmas.  
Love  
ERIC BOOK  
P.S. My sister, Susan, helped me write this.

Dear Santa Claus,  
How are your reindeers and elves? I've been a good boy. I would like a MicroMachine City, and a Fire Station Lego Set. I will have some cookies and milk set out for you.  
Love  
KYLE HOELTING  
Age 4

Dear Santa,  
what I would like For christmas is a Lego Cop City, a bike, Lego castle and whatever else you want to bring.  
Love  
BRADY SCHULTE

Dear Santa,  
How are your raindeer and how are you? I have been sorta bad and I hope you will give me some or all of these things. I want a talk boy and a quiz wiz and one of those Emmit Smith shirts the number should be 22 and I would like to have a Dallas Cowboy jacket. The four things that I would really like to have, I really like a race car track and a go cart and a vac man and a computer and a miniature Dallas Cowboy suit.  
Love,  
TYSON SCHULTE

Dear Santa,  
How ar the Ranedeer doing? Could you bring me a new fort and the Lion King Mickey Manye game's for Christmas? and could you bring me a train set? Santa I have been a little bad. But if you don't bring me that fort I understand. I wonder if I could see you Santa. Santa that must be nete to travle all ofer the world.  
Love,  
ORIN SCHULTE

Dear Santa,  
How are your Elfs? Are you going to give me some toys? I hop you are. I am going to set you some milk. I am going to tell you what I want. I want my grads to go up, my hair to grow, a globe that has a hart on the north pole, a snowman like this one, carmufs, and a merry Crismas.  
Love,  
JAMIE BLACK

Dear Santa Claus,  
How is you radierdeer doing? What are you doing those days? How are your elfs doing? I went for Christmas is Kit Kit Kitten. The other thing I want for Christmas is Mr. Donalds set and rabbit slippers. I like you. You have nice and pretty elfs for Christmas those days. Have a Happy Christmas.  
Love,  
KELCEE KLEMAN

Dear Santa,  
How are you doing? I would like a vacman and a strach arm strong. I would also like a Game boy game Donkey kong, and a steel tec drop set. I would also like a tape called Flinstones and a soccer ball.  
Love,  
JASON WILHELM

Dear Santa,  
I have a lose tooth. I can't wait for Christmas. It is faivrit time of December. May I have a new 2 whell bicke.  
Love,  
MELINA BRADDOCK

Dear Santa Claus  
How are your rein deers? I want a jeep. I want a bike. I want a video game. I want some k-nex. I want some tools. I want a B-B gun. I want a gun set.  
Love,  
MICHAEL ACKER

Dear Santa Claus,  
How are you doing? How are your elves? I would like a skatboard, ich-a-skich and a batman car, batman house, batman, Robin, Super-van-city made for micoshyns. I would like a plow for my shrakter, play house, play cows, play sheep and play goats, starbl, legons, mach box cars, car case.  
Love,  
MICHAEL HORN

Dear Santa,  
I have been a very good boy this year. For Christmas I would like a red power ranger set and suit, a tool set, a farm with horses, a hockey and soccer set, and a Triple Arcade. Thanks! Have a Merry Christmas and Bundle up tight.  
TROY RAMAEKERS

Dear Santa Clause,  
I want a McDonalds Happy Meal maker. Also please bring me an Army Castle with little men to play with. I love you Santa.  
BRANDON

Dear Santa,  
I have been a good girl. Please bring me a Hidden Treasure bike. Please bring me a Gymnastic Barbie and please bring me a Barbie remote control car. Please can you bring me these things. I love you.  
Thanks,  
HOLLY KLEMAN

Dear Santa,  
I'm happy you are Santa, and you help us celebrate Jesus birthday. I hope the elves can sew me a power ranger suit and build me a big ship. Dont forget those kids that need someone to love them. I hope Rudolph can lead the way in the night. I love you and have a happy New Year! The end.  
MATTHEW BIRKENFELD

Dear Santa,  
I've been a very good girl. Please bring me Barbie Playhouse, Babysetter Skipper, Horse, Candyland Game.  
See you Christmas.  
Love,  
MACEE SCHULTE

Dear Santa  
How are you? Please bring me a bat and ball, some jacks. I would like some new boots mine are too small for me. I also like books. Say "Hi" to Mrs Santa Claus.  
Your friend  
JACOB BRADDOCK

Dear Santa,  
How is Rudolph? I hope he is fine. I have been a very good boy. Please bring me a bicycle helmet and a toy Christmas tree. Thank you, Santa. Have a Merry Jolly Christmas.  
Love,  
VAL

Dear Santa,  
I want a Power Ranger Suit. Reindeer.  
CHASE

Dear Santa.  
Teddy Bear, Lunch pail. Thank you.  
Love,  
AMANDA



**Behold the Lamb of God, which taketh away the sin of the world.** *John 1:29*  
May you be blessed with peace and understanding throughout this holy season.

**Pro-Ag, Inc.**

Just a few handy words to express our profound gratitude...

**MERRY CHRISTMAS AND MANY THANKS!**

**Ed Harris Lumber Hart**

**Merry Christmas To All And To All A Good Night!**

Thank You For Your Unfailing Support.

From eastside to westside  
And all around the town  
May peace and happiness  
Blanket the town.  
And to all our good friends  
Both far and near—  
A very good Christmas  
And a happy New Year.

**The Company Store and The Hart Beat Hart**



**GOODPASTURE, INC.**

And the angel said unto them, Fear not: for, behold, I bring you tidings of great joy, which shall be to all people. For unto you is born this day in the city of David a Saviour, which is Christ the Lord.

**Luke 2:10-11**

**HAPPY HOLIDAYS!**

Here's wishing you and your family all things merry and bright this Christmas. Thanks for lighting up our season.

**Oasis Package Store Nazareth**

**SEASON'S GREETINGS**

We hope yours is a celebration of love and laughter this Christmas. Thanks for visiting us this year!

**Jerry's Automotive & Machine**

647-5623 310 E. Bedford, Dimmitt

**Catch The Christmas Spirit!**

Before everyone becomes feverishly wrapped up in preparing for the big day, we just want to wish everyone a very merry Christmas and send out our thanks for your support!

**Look Cattle Feeders, Inc.**



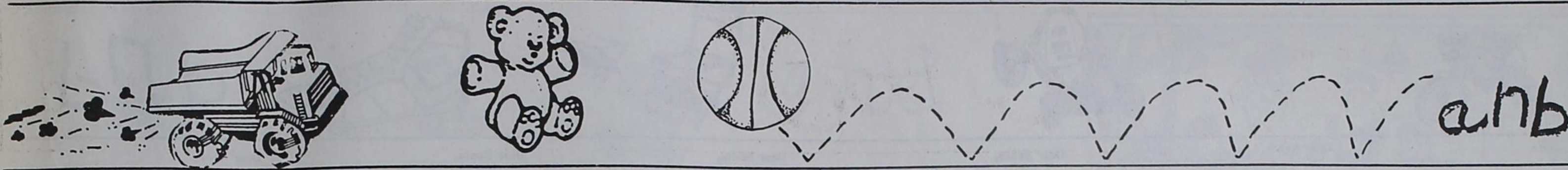

**My Christmas List**  
 Dear Santa,  
 I would like to get: jurassic Park cars Red Power Ranger Suit, Dinosaurs, Play gun, Buffalo, Flintstone Playset, Army Play Set.  
 KEEAN LILLEY

Dear Santa,  
 I have been very good.  
 I want a Power Ranger and I want some Roller Blades. I want a game gear and some games for it. I've really been good this year.  
 Love,  
 SKYLER BIRKENFELD

Dear Santa,  
 How are you doing.  
 I would like a birdie car and a horse and jumpse and a tea party set.  
 Love,  
 TERIN ROSS

Dear Santa,  
 How is Mrs. Claus? For Christmas I would like a 26 in. 10 speed bike, raido remote control car with a battery pack, 2 secret send 6,000. My sister wants a little bike, baby, Bedtime Barbie, and a doll stroller.  
 P.S. We will leave you cookies and milk.  
 Love,  
 CAITLIN AND EVAN HUSEMAN

Dear Santa,  
 Please bring me a Batman toy, a Power Ranger, and Robin.  
 Love,  
 CIRIS POMPA

Dear Santa,  
 How are you and Mrs. Claus. I am fine. For Christmas could you bring me a picture of you, your reindeer and Mrs. Claus. a cartoon shirt with Santa the reindeer and Mrs. Claus, earings with one pair that is Santa with his checks bright red, and the other with reindeer and it is Rudlph with his nose red, and a koosh ball. I hope you will come! There will be a note by the cookies.  
 Sincerely,  
 KIMBERLY BROCKMAN

Dear Santa,  
 I would like a pair of shoes with lights, and a pair of mittins I am leaving you cookies and milk tell your little dwarfs hi  
 CIANDRA JORDAN

Dear Santa,  
 I would like a soccer ball and a foot ball t. I also want a hop a roo balls, A skate bord, some skates, a book, a horse, a Lion King tape.  
 Love,  
 ALAN GERBER

Dear Santa,  
 I want a Vac Man and I want a robot. I want a big candy cane full of toys and I want a nerf ball. I want a hockey stick and I want a race track. I would like my four front teeth and I want a remote control car that squirts water. I want the Santa Claus the movie, and I want a new cap and I want a new baby. I Want a Lion King puppet. I want some roller blades and I want a snowman that is made out of wood. I want some more jeans and a candy cane.  
 Love,  
 SHAY WILHELM

Dear Santa Claus,  
 I want a kitchen and cookies. "I don't want no more stuff."  
 Love,  
 ALEXANDRA OLIVERA

Dear Santa,  
 I would like a computer, gocart, Sonic and knuckels, genines game, Lion King genins game, triple wheels, animaniacs genines game, Santa and your reindeer, and the tape Lion King. I want a pct fish too. How are you.  
 MONTY HOELTING

P.S. Can I have two pairs of secret senders 600.  
 P.S. Can I have a leather jacket.

Dear Santa,  
 Could I please have a Dance N Twirl Barbie doll. And some skates, and a bike.  
 Thank you,  
 BRANDI OLIVERA

Dear Santa,  
 How is Ohber doing and Ruedoghs nose? Oh! back to bussis I would like a gocart for Christmas and a super nes nentendo allsa. here is a little song. Jingle bells jingle bell oh what fun it would be to ride in your sleigh. Oh one more thing I would also like a Troy aikmin miniature football suit.  
 Your friend,  
 GARRETT KLEMAN

I have been good.  
 Dear Santa,  
 I want a tonka truck. I want a remote control car. I want a gameboy. I would like to have some k-nexs. can I have a power Ranger.  
 Love,  
 KRIS ROSS

Dear Santa,  
 What is your wife's name? Do you wear a red hat? Do you wear a red dress? Do your elves make toys?  
 Please, can you bring me a Red Ranger and a dinosaur. Also, I want Red Ranger clothes for me.  
 Please bring Jonathan some Logo blocks. (You've already met my baby brother, Jonathan.)  
 Love,  
 JOSHUA GAMEZ

Dear Santa,  
 I would like a play parrot that talks. He says whatever you say back to you. I also want a flag so that I can say the Pledge of Allegiance. I would like a stuff animal dog.  
 Love,  
 ZACK STARLING

Dear Santa,  
 I want two play guns. I want a go cart. I want a Power Ranger suit.  
 Love,  
 DUSTY BRADDOCK

Dear Santa,  
 Please bring me a baby doll and a stroller, a Barbie doll, a bike, a dress, a stove, a baby bottle, a pencil, a slide, a swing, a pair of dress shoes, a wagon, and a pair of socks.  
 Love,  
 JENNIFER SAENZ

Dear Santa,  
 How are the reighdeer? I would like an elevator that looks like ours. Make sour that my trucks can fit under the augers. I would also like a gin with two or one mogle trucks, mogle truck shed, gin office and the gin part. I would also like a picture of what Parrot or Jumbo school looked like.  
 Love,  
 ROSS BIRKENFELD

Dear Santa,  
 I want two play guns. I want a go cart. I want a Power Ranger suit.  
 Love,  
 DUSTY BRADDOCK

Dear St. Nick,  
 Please bring me four meg of RAM, and Ann four meg of RAM, and Paula 24 meg of RAM, and don a new computer.  
 I also need to win the lotto, Santa.  
 Love,  
 FLETCH

Dear Santa,  
 I want something for Christmas. I want a big truck and a bunch of toys. I want a big airplane and a flyer deal.  
 Love,  
 TOMMY HOWELL

Dear Santa,  
 I want a hat, a kitchen, play dress-up shoes, and skates.  
 Love,  
 HEATHER MARTINEZ

Dear Santa,  
 Please bring me a Barbie, a bike, and a play dollhouse.  
 Love,  
 LARAINA AGUERA

Dear Santa,  
 Please bring me a White Power Ranger with a knife and a tiger.  
 Love,  
 MICHAEL MARTINEZ

Dear Santa,  
 I want a bike. I also want a sega, a tank, a football suit, a football, a big 4 wheeler, and a tv. Have a merry Chistmas.  
 Love,  
 NATHAN HUSEMAN

Dear Santa,  
 Please bring me some markers, a coloring book. Could you buy me a bike?  
 Love,  
 AMANDA CASTANEDA

Dear Santa,  
 Please bring me real skates, a doll house, a coloring book and a basketball.  
 Love,  
 ASHLEY PATLAN

Dear Santa,  
 Please bring me some gloves and this many—5 toys (a whole bunch).  
 Love,  
 JEREMIAH LUNA

Dear Santa,  
 Please bring me some Power Ranger toys.  
 Love,  
 JONATHAN GARZA

Dear Santa,  
 Please bring me an Aladin toy and some clothes.  
 Love,  
 ANTHONY ENRIQUEZ

Dear Santa,  
 How are you? I am fine. I have been a good girl this year. This year for Christmas I would like a Dreamland Baby, a stroller, a snow cone maker, and a game. I will leave you some milk and cookies. Thank you.  
 I Love You,  
 CASSIDY WATTS

Dear Santa,  
 I want a tiger sword.  
 Love,  
 FRANKIE RODRIQUEZ

Dear Santa,  
 Please bring me a Power Ranger, toothbrush and 2 loud guns.  
 Love,  
 NATIVIDAD SIAS

Dear Santa,  
 Please bring me a Power Ranger and some clothes.  
 Love,  
 ISIDRO RODRIQUEZ

Dear Santa,  
 Please bring me Power Rangers.  
 That's all!  
 Love,  
 CASEY ENRIQUEZ

Dear Santa,  
 I have been a good little girl this year. I would like you to bring me a Dreamland Baby, a stroller, and something really neat in my stocking. Thank you.  
 I Love You,  
 CATLIN WATTS

Dear Santa,  
 Please bring me a gun, a Power Ranger, and a little stereo that you talk into—the thingy like a star.  
 Love,  
 GEORGE ANTHONY LOPEZ

Dear Santa,  
 Please bring me a toy car, a Barbie, and a Barbie house.  
 Love,  
 VANESSA REYES

Dear Santa,  
 Please bring me a train and a toy reindeer.  
 Love,  
 ANTHONY PUENTE

Dear Santa,  
 Please bring me a Dallas Cowboy football, a radio control, and a video game.  
 Love,  
 LUIS LUNA

**HERE IT COMES!**

Another fun-filled season...  
 And all of you are the reason;  
 We've slid in to say,  
 "Have a great day!"

Merry Christmas.  
 Thank you for choosing us.

**Cargill, Inc. Molasses**

**SEASON'S GREETINGS**

Wishing a very merry season to all of our friends.  
 Thank you for your support.

**Triple A Pump Co., Inc.**  
 Hart

**ALL THE BEST TO YOU!**

In keeping with the spirit of the season, celebrate with friends and family and please accept our sincere thanks for your support.

Happy Holidays!

**Ernie's Bar-B-Q**  
 Ernest and Eva and Family

Dear Santa,  
 How are you doing? How is Rudolugh doing? All I want is four things. A My Size Bride Barbe, Jasmine suit and to give presents to the kids that don't have any toys and if some kids have mommys and daddys that don't like them to bring them new mommys and daddys.  
 Love,  
 JAMIE BIRKENFELD

Dear Santa,  
 How are your elfs doing? Are your Reindeer cold too pool your sleagh? I want a pool table that has three games to it a reamoke control car, a camra, a nentendo that has all the games too it. I want some mouse traps, I want some new John Deere work close, I want some car phones that has a raido with it, I want a real seb, I want a tipewriter, I want a computer, I want a desk to do homework, I want a reamoke control air plane, I want a touzen dollars, I want a million dollars, I want a big a candy cane and stocking full of prizes.  
 Love,  
 JEREMY ACKER

Dear Santa,  
 I have been a good girl this year. I would like you to bring me a Dreamland Baby, a stroller, and something really neat in my stocking. Thank you.  
 I Love You,  
 CATLIN WATTS

Dear Santa,  
 Please bring me a gun, a Power Ranger, and a little stereo that you talk into—the thingy like a star.  
 Love,  
 GEORGE ANTHONY LOPEZ

Dear Santa,  
 Please bring me a Power Ranger and some clothes.  
 Love,  
 ISIDRO RODRIQUEZ

Dear Santa,  
 Please bring me Power Rangers.  
 That's all!  
 Love,  
 CASEY ENRIQUEZ

Dear Santa,  
 I want a tiger sword.  
 Love,  
 FRANKIE RODRIQUEZ

Dear Santa,  
 Please bring me a toy car, a Barbie, and a Barbie house.  
 Love,  
 VANESSA REYES

Dear Santa,  
 Please bring me a train and a toy reindeer.  
 Love,  
 ANTHONY PUENTE

Dear Santa,  
 Please bring me a Dallas Cowboy football, a radio control, and a video game.  
 Love,  
 LUIS LUNA

Dear Santa,  
 Please bring me a sword and a cap gun.  
 Love,  
 CHRISTOPHER GREGORY

Dear Santa,  
 I want a Power Ranger, toothbrush and 2 loud guns.  
 Love,  
 NATIVIDAD SIAS

Dear Santa,  
 Please bring me a toy car, a Barbie, and a Barbie house.  
 Love,  
 VANESSA REYES

Dear Santa,  
 Please bring me a train and a toy reindeer.  
 Love,  
 ANTHONY PUENTE

Dear Santa,  
 Please bring me a train and a toy reindeer.  
 Love,  
 ANTHONY PUENTE

**All Good Things On Christmas**

We hope you get everything you wish for this season. You already have our gratitude for all you've done. Merry Christmas to each and every one.

**Don's Wrecker Service and Body Shop**

**home for the holidays**

We're so happy you're part of our extended family.  
 May joy and peace be with you, now and always.

**Cowsert Abstract & Title**  
 Clara Vick

**Deck the halls**  
 with boughs of holly!  
 Our hopes are with you for a splendid holiday. Thanks, everyone for your loyal support.

**Don Hargrove Construction**

**A YULETIDE BLESSING**  
 May you and yours enjoy a memorable and peaceful season of sacred celebration.  
 We appreciate your support and friendship.

**The Fabric House**  
 647-3307 • 113 SE 2nd, Dimmitt





and

Dear Santa,  
I have been a very good girl. This year I would like a pair of inline skates, a helmet that's black or white, and anything else you want to give me. If you give me the presents, next time I write a letter to you it might have a thank-you thing in the letter. Please have a good trip! Oh! I forgot something, can I have some kitty and puppy stickers?  
Love,  
TANYA HERRING  
P.S. I want the horse at Alco that we saw.

Dear Santa,  
How are you and Mrs. Santa Claus? How are your reindeer and your elves? I hope you have a fun time dropping the present. Santa for Christmas I would like a 10 speed and a Jamsen sute and 2 more thing a my size barby, Dallas cowboy jacket. Santa I might have had bad to deserve the things. Happy Christmas eve.  
Love,  
JORDAN HAMPTON

Dear Santa,  
I would like to have these things for Christmas a Dance and Twirl barbie. How about an Alarm clock. I like radios. Well I know that is not much but that is it. Please bring it to me.  
CASSIE PRICE

Dear Santa,  
how are you and Mrs claus and the elves. I want a mighty morphin power Rangers game and the lion king for my super nintendo. My sister want's a my size Barbie and a swim 'n dive barbie. I want the movies flinstones and Beethoven's 2nd and Jurassic park. and Homeward Bound and I want a little cat.  
Thanks Santa  
NATHAN OLVERA

Dear Santa,  
Please bring me a My Size Barbie, a Belle costume and a Pink Power Ranger.  
Love,  
CHRISTAL OJEDA

Dear Santa,  
Please bring me a toy tiger, a Red Ranger and markers.  
Love,  
LEEROY MARTINEZ

Dear Santa,  
How are you feeling and your wife. Man I cant wait intill christmas can you. OK here's what I want for X-mas I want the flip over yellow ranger and and a bicycle and my stoking fild with a bunch of goodies for me to eat and to play with. Well that's all I want for X-mas. Good-bye Santa  
Your kid,  
ADAM HUNTER

Dear Santa,  
Are you very buzzy? Would you please send me a Keybord, poster, and puppy suprise. I would also like a Twist 'n Twerl barbie, and I forgot to put a music book to come with the Keyboud and please sind me a tape of Crismas songs.  
Your friend,  
KELI SCHULTE

Dear Santa,  
What I want for Christmas is GamBoy hot wheels, tv, clothes, Dallas CowBoys hat, car crush and Rock Runner, High-speed Tsauro Z racer. That is all I want for Chirstmas.  
RICKY PENA

Dear Santa Claus,  
How are you and how is Mrs. Santa Claus? For Christmas I want a 4 in 1 tournament table and 2 power rangers. I want a power rangers sega game gear game. I want some micro machines and some trolls. Thank you for the presents you gave me last year. Tell Rudolph hi for me and ask him how he is too.  
Sincerely,  
ANDREW BROCKMAN

Dear Santa,  
Please bring me a Loopy Louie, a backpack, colors and a coloring book.  
Love,  
ROCKY NAVARRO

Dear Santa,  
Please bring me a Batman colors, a Red Power Ranger, and some markers.  
Love,  
JESUS ORTIZ

Dear Santa,  
I have been good this year. I just want one thing this year. Could I have a sky suit?  
Love,  
TREY ROBB

Dear Santa,  
I would like to have a big Troll. I also would like a Pyhon, cool tools, a truck, a carlor flasher, and a fisher price game bord. A Lion King tape would be nice. I had been a good boy.  
Love,  
JAKE HOELTING

Dear Santa,  
I know you ar buzzy and everything but what I rily want for chismas is a new bike.  
DARLENE MORALES

Dear Santa Claus,  
How is the Santa workshop goin? Are the Elves tired of making toys yet. I've been pretty good this year. I want a technic set and Risk the board game. Merry Christmas to you, Mrs. Claus, and the elves. If I asked for too much give some to the kids who need it.  
Your Friend,  
BROCK (BUBBA) BIRKENFELD  
P.S. Don't work too hard on getting the toys around the world.

Dear Santa,  
Please bring me a Barbie doll. Reuben (my brother) needs a remote control car.  
Love,  
STEPHANIE ZAMBRANO

Dear Santa,  
Please bring me a Barney, a White Power Ranger and a backpack.  
Love,  
GEORGE DONES

Dear Santa,  
I have been good this year. Thank you for the presents from last year. This year I would like a Dear Diary, two Kitty Kitty Kittens, a cabbage patch doll and clothes for it, T.V. with V.C.R., stereo, Secret Sender 2000, Walkie Talkies, Roller Blades and a Kitty Surprise. Thank you.  
SHEENA EHLV

Dear Santa,  
I want paper, tablet and a teacher book. I want a pey Baby. I want a dress and biker shorts. I want a Cheerleading suit. I want roller skates and a bike. I have been good.  
Love,  
KASEY WOOD

Dear Santa,  
I would like a computer for Christmas. I want a computer because I can play games on it and do all my homework on it. And when my friends come over we can play with the computer, and I also want a go cart. I want a go cart because I like driving and I can drive it up and down the dirt road I live on.  
P.C. Santa hope you don't forget about Christmas.  
Love,  
MISTY BURTON

Dear Santa,  
I would like you and Mrs. Claus to have a Merry Chistmas. Somethings I would like are pet shop polar bears, penguins, seals, a leather jacket and the move Flinstones.  
Merry Chistmas  
Love  
SARAH ELLISON  
P.S. Adrian wants a Polly Pocket.  
P.P.S. You don't have to get it all.



**We're SOLD...  
On Neighbors Like You!**

We couldn't have asked for a finer community to do business with. May your home be blessed with contentment, prosperity and joy this holiday season.

**GEORGE  
REAL ESTATE**

**Let Us Therefore Follow  
After The "Things Which  
Make For Peace."  
—Romans VIII:28**

As we celebrate the birth of the Prince of Peace, we join you in envisioning a world in which our fondest hopes may come to pass.

**Kern Plumbing  
& Electric**

Nazareth

**WITH OUR THANKS,  
AT CHRISTMASTIME**

Of all the places in the land, we're glad we've settled here. Thank you for helping us to have a truly fruitful year.

**Flagg Fertilizer Co.**



**A Christmas  
WISH  
For You!**

Here's hoping that all of your wishes come true in this most magical of seasons!  
Merry Christmas and thanks to all!

**B&W  
Aerial  
Spray**

Dear Santa,  
I want a Jambox and a pea Baby. I want a bike and a drum. I want a soccerball. I want A play monkey and a tape of the chip munks. I have been good.  
Love  
DAWN CAMERON

Dear Santa Claus,  
How are you doing.  
I was in builider □ yester dag.  
I saw you snorin kooooo z z z z .  
I wanted t get it but to mach it was 50 somthen bolers. Know want my sizse Brbue I cant. It's to cutch. But hius my list. A rado, and coutry kitchen that's all thank you.  
lovs,  
SIERRA WILCOX

Dear Santa,  
I have been very good. How is Mrs. Clause and the reindeers doing? Is it snowing in the North Pole? It sure is not snowing here. And I want to know if your sleigh is ready to deliver me a 72 x 42 inch pool table also I want a bicycle helmet for roller blading and bicycling. I hope you have a wonderful Chirstmas.  
BRETT HOELTING

Dear Santa,  
I want a doll.  
I want a baby seat.  
I want a stroller.  
I want a bike.  
I've sort of been good.  
Love,  
KENDRA HUSEMAN

Dear Santa,  
I want a make-up and Grooming play set. I also want a Telephone Tammy. I hope you have a merry Christmas.  
Love,  
J'LAE MERRITT

Dear Santa,  
I want a Power Ranger Wrist band. I also would like a creepy crawler, a bike, and some roller skates. I have been good.  
Love,  
LACEY SANDERS

Dear Santa,  
Please bring me a dancing Barbie, a Barney, and a bike.  
Love,  
NAYELI MONSIVIAS

Dear Santa,  
Please bring me a toy Santa.  
Love,  
RICKY CAMACHO

**WISHING  
YOU A  
STOMPING  
GOOD TIME!**

We sure do appreciate your loyal patronage.

**Dale's Auto  
& Salvage**  
Nazareth

Dear Santa,  
I hope you will have a good Christmas this year. I hope Mrs. Claus is all write. I love Christmas because it was when Jesus was born. I would like to have four new teacher books. I want a chalk dill so you won't get chalk on your fingers. I want a real dimond ring. I want a broomstick skirt that is down to my feet. I want a baby doll house and a barbie doll house that has a pool in it so the barbie can swim. I have a sister and brother that have been good this year. I have been good this year too. There names are Kasey and Lane. We wish you a merry Christmas. We wish you a merry Christmas and a happy new year.  
Love,  
LINDSEY

Dear Santa,  
Please bring me a Pink Power Ranger, and bike pump up.  
That's it.  
Love,  
ASHLEY FLEEKS

Dear Santa,  
Please bring me a Batman toy, a Red Ranger, a White Ranger, and some colors.  
Love,  
SAMMY SANCHEZ

Dear Santa,  
Please bring me a doll.  
Love,  
HAYLEE EVANS

Dear Santa,  
Hi! My name is Patricia Barrera. I've been good. I want a play horse, ball and a game for Christmas. I would also like some dress up shoes and clothes to play in.  
Goodbye  
PATRICIA BARRERA

**An Old-Fashioned  
Christmas Wish**

*Christmas has always meant reflecting upon one's blessings. We wish much happiness to all who bestowed good fortune upon us this year. God bless you all!*

**Panhandle Building  
Services**

**Behold, a virgin shall be with child, and shall bring forth a son, and they shall call his name Emmanuel, which being interpreted is, God with us. Matthew 1:23**

May The Miracles of the Season Be Bestowed Upon You.  
Thank You For Your Friendship.

**3 RAFTER 3 FEEDYARD, INC.**





and

**Dear Santa,**  
My name is Michael Miller. I am 7 years old. I am in First Grade. I live in Hart, Texas. I have been a good boy this year. For Christmas I would like a ball, roller blades, a game, a bow and arrow gun, a creepy crawler machine, a color blaster, weights, a army set and a bat man gun. I love you Santa.  
Love,  
MICHAEL MILLER

**Dear Santa,**  
My name is Ashley Torres. I am 7 years old. I have been good. I live in Hart Texas. I am in First Grade. I would like a barbie car, a vase for my mom, a barbie house for me, a bike, a book, a computer, a little bed for Barbie and a Barbie van. I love you Santa.  
Love,  
ASHLEY TORRES

**Dear Santa,**  
I want:  
A fish tank, a swimming pool, a Super Nintendo, & 2 more plants.  
ALYSSA RITTER  
Roller blades, a play farm & a pipe fighter car racer.  
TUCKER WAGGONER

**Santa,**  
I want red truck with a trailer on it and helicopter with a fan on it that goes around and lights. I want an airplane and a Fire Engine and a Fire hat and coat and phone in the pocket, and ax, a star and a bird. I Love You.  
CHRISTOPHER CLEVINGER

**Dear Santa,**  
My name is Krista Carrasco. I am 6 years old. I am in First Grade. I live in Hart, Texas. I have been good. I would like a Barbie car, a black cat, a puzzle and a doll house. Have a Happy Christmas Santa.  
Love,  
KRISTA CARRASCO

**Dear Santa,**  
My name is Andrew Dudley. I am six years old. I have been good. I live in Hart Texas. I am in First Grade. I want some Ninja turtle things, a ball, and a game boy. I would also like some batman stuff for christmas. hope you have merry Christmas and tell everyone at the north pole hello for me.  
Love,  
ANDREW DUDLEY  
P.S. I have Been a very goodboy.

A toy reindeer, a Super Nintendo & an airplane game.  
ADAM VELASQUEZ  
A dolly, another kitty, a car, and a backpack.  
BRITTA SCRUGG  
A Sega and a play farm.  
BRENNEN RODRIGUEZ  
A car and a computer.  
FERNANDO RAMIREZ

**Dear Santa,**  
My name is Mario. I am 6 years old. I live in Hart, Texas. I am in the First Grade. I would like a Beethoven book, a motorcycle toy, a toy horse, a wagon and a fire engine. I would like to wish you a Merry Christmas Santa.  
Love,  
MARIO RIOS

**Dear Santa,**  
My name is Eric Menchacca. I am six year old. I live in Hart, Texas. I am in the First Grade. I would like some connects, a motorcycle bike, XMEN, a batman and a GJOE boat and man. Please you and your reindeers don't lose the way to my house.  
Love,  
ERIC MENCHACCA

**Dear Santa,**  
My name is Chewy. I am 6 years old. I live in Hart, Texas. I am in the First Grade. I would a Power Ranger, a truck, a motorcycle, a batman toy, a train, a toy suburban, a tractor and a new toy house. I wish you a Merry Christmas Santa Claus.  
Love,  
CHEWY VEGA

A real cat, a real cow and a real horse.  
BENJAMIN MONTEMAYOR  
A closet, a real cat, a real dog and a new backpack.  
ALLAN MONTEMAYOR  
A Barbie house that has things in it and an upstairs, a doll, a computer, and a fish.  
MIRELLA MENDOZA

**Dear Santa,**  
My name is Gladys Torres I am 6 years old. I am in First Grade. I live in Hart, Texas. I Have been good. I want a car and a barbi hous and a neckles and a ring and a makup and a big trampoline and a puzzle, and a puppy and a nintendo and a hous and a kit and a telephone and a stereo. I want a babydoll and a play hors. A jopro and I love you Santa. P.S. Santa please bring me a computer so I can get very, very smart.  
Your friend,  
GLADYS TORRES

**Dear Santa,**  
My name is Chelsea King. I am 7 years old. My box number is 151 Ave. B in Hart Texas. I have 1 dog. I am in first grade. I've been good. For Christmas I want a cuddly teddy bear, sewing machine, a color marker and a paint set, a pretty dress, doll with long pretty yellow hair, rill racoons. I hope that you have a mery merry Christmas. Thanks a lot.  
Your friend  
CHELSEA KING

**Dear Santa,**  
I want a 271 pickup. I want a motorbike. I want a 22 gun with a scope. I want \$39000 bucks. Here are some of the things I van wants for Christmas. First, He wants a stereo. He also wants a new sweater because it gets verycold sometimes. The last thing he needs is a car.  
Love,  
ORRIN McLAIN  
IVAN

A little car and a real cat.  
JOEY LLAMAS  
A little pony, another Barbie car, and a doll.  
LINDSAY GEORGE  
A Power Ranger (red and blue ones), a car, a motorcycle, a gun, a mask and a real horse.  
MARCO CORRALES  
A Sega, Sonic & Tails game & a farm set.  
BERRY CLINTON

**Dear Santa,**  
If it is ok, please bring me a telescope and my brother a cool tool work bench. If you do not have enough time, that is ok.  
Love,  
STUART SHEFFY

**Dear Santa,**  
My name is John. I am 6 years old. I live in Hart, Texas. I am in the First Grade. For Christmas I would like a toy fox, a batman car, a Power Ranger, a airplane, a book about Santa Claus and a toy dog. I wish you a Merry Christmas Santa.  
Love,  
JOHN CORRALES

**Dear Santa,**  
Cassie and Lisa have been very good girls this year. Cassie would like lots of clothes, a watch and some CD's. Lisa would like a jumpsey, some clothes, and a big surprise.  
your friends,  
LISA LOPEZ  
CASSIE NEINAST

A truck, a green Power Ranger, and a tape player.  
DAVID GUERRERO  
A power ranger & a dinosaurs—a bunch of dinosaurs  
ADRIAN ROSAS  
A truck, a car and a Power Ranger.  
MIGUEL ORTEGA

**Dear Santa,**  
This year I have been a good girl. So for Christmas I want a black baby doll.  
Love,  
LESLEY

**Dear Santa,**  
My name is Marisol Arellano. I am 7 years old. I am in First Grade. I live in Hart, Texas. I have been good. I would like a car, a Teddy Ruxpin, barbie house, a Christmas tree, a book, a Santa ring, a play dog, a baby car, a trampoline, a computer and a water baby. I would like to wish you a Merry Christmas.  
Love,  
MARISOL ARELLANO

**Dear Santa,**  
Osbaldo wants a gun and some fish. I want a gun and some gold fish. I have been a good boy this year. I also want a football and a new teacher. Osbaldo also wants a stereo with some CD's. I want a white power ranger, watch, and a sega.  
Love,  
CHAVO HERNANDEZ  
OSBALDO CARRASCO

**Dear Santa,**  
I want a cop, and a fire truck, and a green tractor.  
Your friend,  
CHARLES BANN

**Dear Santa,**  
I loved the things you gave me last year. Do you know what I want for Christmas. I want a car and a truck. And a rattler and a real cat and dog and pants and t-shirts and a toy Santa Claus.  
Love,  
JOSHUA DOMINGUEZ

**Let There Be LIGHT**  
Let there be joy. Let there be all things merry and bright for every girl and boy.  
Merry Christmas!  
Bennett Grain, Fertilizer & Cattle  
Hart

**HOPE YOUR SEASON IS TREE-MENDOUS!**  
We're truly grateful for your friendship and support.

**Hart Producers Co-op Gin**

**Dear Santa,**  
I want Santa and Christmas toys and Barbie.  
Your friend,  
CASSONDR A RODRIGUEZ

**Hi Santa,**  
I want a Barbie and a pretend Santa Claus, and a little Snowman and a Christmas tree, and a Barbie car.  
Your friend,  
NANCY MONTEMAYOR

**Dear Santa,**  
I want Game Gear and B-B gun and play John Deere tractor 'cause my others tore up. I Love You.  
SETH McLAIN

**Dear Santa,**  
I want John Deere tractor and a White Power Ranger and a big motorcycle. I Love You.  
JOEL VEGA

**Dear Santa,**  
Please take care of those children that need food and clothing and medicine. I've been good this year not lot, if you can get me a sega and a Dallas cowboy football and Dallas jacket a remot control car and a pin-ball machine.  
Love,  
JAVIER RODRIGUEZ

**Dear Santa,**  
Thank you for my gifts last year. I enjoyed them a lot. I want a game boy and a bike and a lamp and a power Ranger and a Power Ranger walet and a Dallas cowboy helmet and a desk and a pillow. Santa Claus Love I you so much. Merry Christmas Santa Claus  
ALBERT RUIZ

**Dear Santa,**  
I want a bike for Christmas sega and a game of The Lion King, and Mortal Combak, and a Bump Bed and thank you for everything.  
Love,  
CARLOS CHAVEZ

**Dear Santa,**  
Beau, Taylor and I are glad you brought us toys. I'll start with Beau and he wants some Bat Man stuff and trucks and Taylor wants baby stuff and I want some Moon Shoes, Sega CD 2 System and Deluxe Takeboy and one more thing a Master Video Panter. Thank you.  
Love,  
RAYNEE BRADLEY

**Dear Santa,**  
Can I plesse have a football and can my little sister can have a girl car and my mother can have some money and can my dad can have some money to.  
Love,  
CEILES ESCERRILLO

**Dear Santa,**  
I love you. I wish you could please bring me my size barbie and a new bike. Also a little rabbit. But I wish you stii could bring all these toys. Can you reali bring the m?  
Love,  
LILIANA AGUILAR



**A Warm Christmas Wish**  
We hope your family celebrates with good cheer and good friends. Thanks for visitng us all year long!  
**Hockhart Pharmacy**  
107 E. Bedford, Dimmitt 647-3392

**SEASON'S GREETINGS**  
The spirit is building and we'd like to say, hope your season is made for you in every way.  
Thank you for choosing us.  
**Higginbotham-Bartlett Co.**  
109 N. Broadway, Dimmitt 647-3161

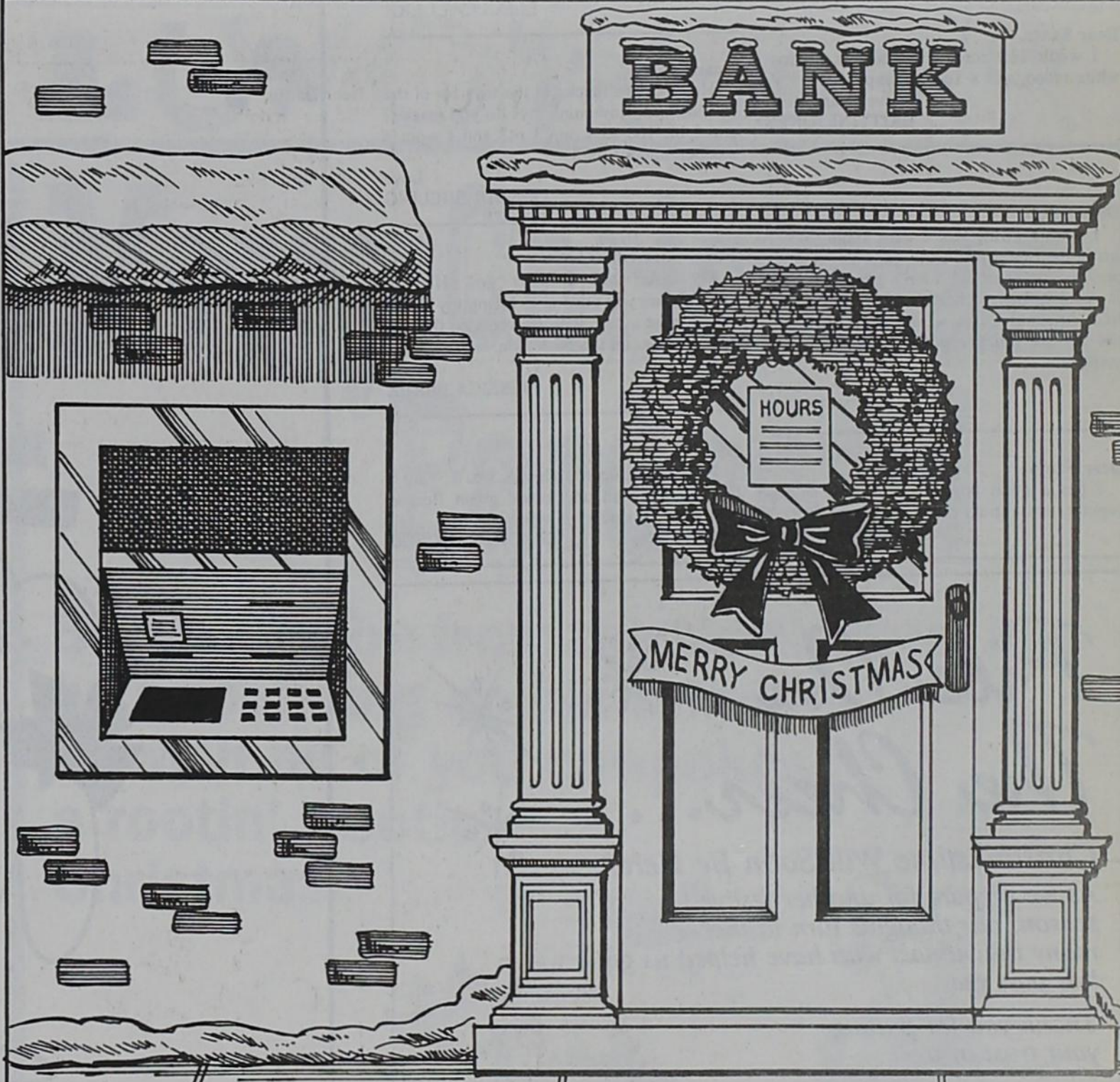

**Happy Holidays**  
Here's hoping your Christmas yields big returns! We value your business and your friendship.  
**"Your Community Bank"**  
**HCSB**  
HALE COUNTY STATE BANK  
MEMBER FDIC  
**HART BANKING CENTER**



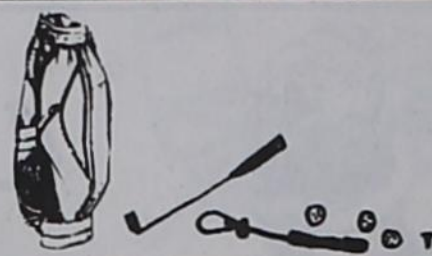

and a

**Dear Santa,**  
I hope I have been a good boy. I hope you could bring a little of something like a football helmet and Shoulder pads and a Jersey. Thank you for the presents last year. I hope you have a merry Christmas.  
Love,  
JONATHAN WELCH

**Dear Santa,**  
I loved the presents you gave me last year. This year I want a bike and swing set and a trampoline and a sega. Thank you for all the presents you have gave me.  
Love,  
RICKY REYES

**Dear Santa,**  
I want a tournament table and Ask Landar and Perfect Match. And thanks for last years toys. Write back soon. Thanks.  
Love,  
MEGAN

**Dear Santa,**  
I thank you Santa Claus for all the things you have given me last year for Christmas. I want a bike. That is it.  
Love,  
CHARLEY SAENZ

**Dear Santa,**  
I would like you to bring me a ninetndio and a little car for Christmas that is all I would like I hope to see you soon. Thanks.  
RAPAEL G.  
P.S. Have a Merry Christmas

**Dear Santa**  
I been good  
I want a bardie car  
I want a trampoline  
I want a bike  
I want a playhouse  
Have a merry Christmas and say hi to Mrs. Clause.  
Love,  
CLARISS SANCHEZ

**Dear Santa,**  
I've been a good boy this year. I want Power Ranger dolls and a Sega Genesis with a Power Ranger Game for the Sega, and I want a Teddy Rockspin. Thank you Santa Claus. If you bring um to me.  
Love Always  
SCOTT MARTINEZ

**Dear Santa,**  
I would like a pair of skates and a basketball and a bat and a big foot jeep.  
CODY WEATHERFORD

**Dear Santa,**  
How are you? I have been a good girl. I would like a Lion King Roaring Simba, Snow White Movie and a Make-up Beauty Doll.  
Love,  
ANNA BROCKMAN

**Dear Santa,**  
I would like some roller blades, a snow white video, and a Teddy Ruxpin.  
Love your friend,  
BRITTINI JONES

**Dear Santa,**  
I want a swing and I want some toys. I am in the first grade. I like to read. I like to play. Its fun at school. I am a good girl. how Is rudolph. merry christmas It Is fun here I like christmas I like school santa claus sis ho. ho. ho. I like rudolph It Is fun In my class  
love,  
KRISTY REYES

**Dear Santa**  
I bin a good boy. i wot skates and a keputer. and a mokit cor. i Love you Sant.  
CASEY CABALLERO

**Dear Santa,**  
Thank you for giving me my presents. I want a kitty in my pocket, another puppy in my pocket, and a new Barbie house. I also want some stuff to play in the bathtub.  
ERIN BLACK

**Dear Santa,**  
I want a book, a coloring book, a new movie called *We're Back*, and a Nintendo game. And I want everybody to have a good Christmas and a Happy New Year.  
Sincerely,  
Corrie Kate Black

**Dear Santa,**  
I want for Christmas, rollersbladers, a video of power rangers, Treasure rocks, I want some things for my room, I want a The Lion king stuff animal, gloves of the power ranger that make noise when you wave your hands. See you in Christmas. I will let you some milk and cookies. Mr. and Mrs. Claus I wish you a Merry Christmas and happy New year's.  
SUSANA OJEDA

**Dear Santa,**  
I want for christmas, make up Beauty, Treasure Rocks Box, videos, games of power Rangers, and I want the power Rangers games, and a walkie talkies for me and my sister, and I want a Jackpot pay out, Bedtime Barbie and Swirl Art, and more things I want to tell you I want present for my mom and dad to, and one more thing I want it to snow because last year we were sick we did not play outside and have a nice merry Christmas.  
Love,  
PATRICIA MARRUFO

**Dear Santa,**  
I have tried real hard to be a good boy. Please bring me a train set with a bridge and lots of cars that hook together. My sister Haley has been good too, so please bring her a toy. Please hurry.  
RYAN BIRKENFELD  
Age 2

**Dear Santa,**  
I have been a good boy. Please bring me a blue racer bike and some candy in my stocking. My sister Haley has been a good girl and I think she would like a dream screen. Come soon.  
KYLE BIRKENFELD  
Age 4

**Dear Santa,**  
I love Xmas and you Cause your special. Please send me a Power Ranger and a motorcycle bike. I look forward to seeing you and your Reindeer. I been a good boy.  
JEFFERY NINO

**Dear Santa**  
i want a gi joe  
i am goool  
love,  
ELIAS CALDERA

**Dear Santa,**  
How do you macke ol the toys for ol the chirdin? and How mine toys do you macke? and I bit 100 toys. am I rit? and I wont a tedeber. and a brbe.  
Love  
MANDI EBELING

**Dear Santa Claus,**  
My sister had a baby gril. Hou is Rudolph. are you gowing to bring toy to the kids. I wont a bike with to wecls on the rite and left side. on the back side.  
love,  
JESSICA PEREZ

**Dear santa,**  
I have poot up My chrisst. tree I Want a PowerRager. red and black green fleeson fred. What a slob sage super Nitendo.  
SERGIO SAUCEDO

**Dear Santa,**  
I won a barbe cor thet i can get in and i hope you can breg me sum badres?  
I live on 401 north west forth street. Iv ben a good grl.  
I have a christmas tree.  
And i wot you to have a good merre christmas.  
Love,  
ASHLEY SEARS

**Dear Santa,**  
I wnut a scabord.  
Iv got good grase.  
My hous has brix.  
My buther has bin bad but stil giv im a prent. I have bin a good grl.  
Do you hav a long beard?  
Love,  
DARCY FISHER

**Dear Santa,**  
I want my too front teth and a Big Stuf anmool a Parager a Pink Parager and the sord too and a ten speed too I ben good and Santa I want evrey butey too have a Mery Chrimis.  
Love,  
KENDRA PUENTE

**Dear Santa,**  
I wnt a bike, Santa hal ar your elfs? doon you remember me. I bin goode ulot time. I won a pora ragre I wot green ragre. 1003 w. 10 steet. THE END.  
Love,  
GABRIEL MIRELES

**Dear Santa,**  
I wot a brbe. I got picture uv santa. I did a good job uf culr it. I ben good to mi bruthr and sisdr. I ben good to mi mom and dad.  
love,  
DESIREE SANCHEZ

**Dear Santa,**  
I wot a pora Ragr. it red. Im leve you sum kokes. I got a christmas tree. roky wons a mistrbuk. rudof rader has a red nos. santa gos a red nos. I luv santa.  
luv  
ANTHONY NAVARRO

**Dear Santa Claus,**  
How are you and Mrs Claus. Say hi to your Reindeers.  
I want a talking barbie and a stepping horse some barbie clothes and some clothes for me. I also want a baby doll. Gymnist barbie.  
Can you bring my Cousins Diego S. and Rudy S. some power rangers.  
We have been good kids.  
Love,  
CASSANDRA GARCIA  
P.S. We will leave you some cookies and milk.

**Dear santa,**  
i wot a book i lik tuw read. i am a gud grl. how is reindeer? merry christmas santa sas ho ho i lik reindeer  
Love  
DANIELLA CUVARRUBIA

**Dear Santa,**  
I wot a white and blue kit. who is that reindeer with that red nose.  
Love  
ASIA SPENCER

**Dear santa**  
I wut a car wef lins on The car. I wut a bol wef dos. I wut a robot wef defent kulr. I wut a sly wef brown.  
From,  
chriv Velasquz

**Dear Santa**  
I lik Santa Claus. I wot a bat for Christmas. I wot a slad for Christmas. I wot a truk for Christmas. I wot a sagu for Christmas.  
Love,  
Sean Hunter

**Dear santa,**  
I what a doll house for Christmas. And i what ras car and a hat and a play house. And a slay. And i what a play shep. And i what a boll. And i what a doll that scing.  
Love,  
sabrana paalan

**Dear Santa**  
I What a basket ball golld. and a power ranger game. and a new bike. and a power ranger megasord. and a tree hous and i what a batman. and i what a new game to go whith my game gear. and i what a new game to go with my super nitendo.  
From,  
Ross Hunter

**Hi Santa**  
I want a power ranger that is blue and black. Please bring two—one for my brother. Also a play telephone and a choo-choo train with tracks. I'll leave you cookies and milk and a carrot for the reindeer.  
Goodbye,  
DUSTIN VENHAUS

**Dear Santa,**  
I Want a pink power ranger suit, Barbie horse, and love to play with dress up clothes and shoes.  
Love,  
GILLIAN GONZALES

**Dear Santa,**  
I wut a citen. I bin a god boye. I wut the hol set uv the pawr rachr. I wut a cuptr. I wut a noo bike. I wut a little Christmas tree. I wut a say. I wut a radr. I wut a eliv dog like simin.  
Love  
Jason Todd Corlis

**Dear Santa,**  
Do you remember me at the Korthous. I wot a pooerag Borb it's pink. My beruthr is sutime mean. but He wots a car that gos fast. how is yooer Elfs? do tha do god werk? The End.  
Love  
STEPHANIE ESQUIVEL

**Dear Santa,**  
Me and my sistre ben happe for christmas. Me and my sistre wont a lot of tous miye mom bot me and my sistre sum tous to put udre my tree cud you git me and my sistre tous how is rudolph is he gowen to bi me and my sistre atouy I love you santa  
BO SIFUENTEZ

**PLAY IT WITH JOY!**

*May harmony and joy fill your home and make for a very noteworthy holiday season.*

**Gregory Real Estate**



**SWEET TIDINGS TO YOU**

*Hope your holiday is filled with lots of sweet surprises. Serving you has been a real treat for us.*

**James Cobb Home Repair**  
James & Bonnie



**Pile On The Cheer...**

*Christmastime Will Soon Be Here! As we prepare for another festive season, our thoughts turn to the many individuals who have helped us grow this past year. Thank you for putting your trust in us.*

**Dimmitt Printing & Office Supply**

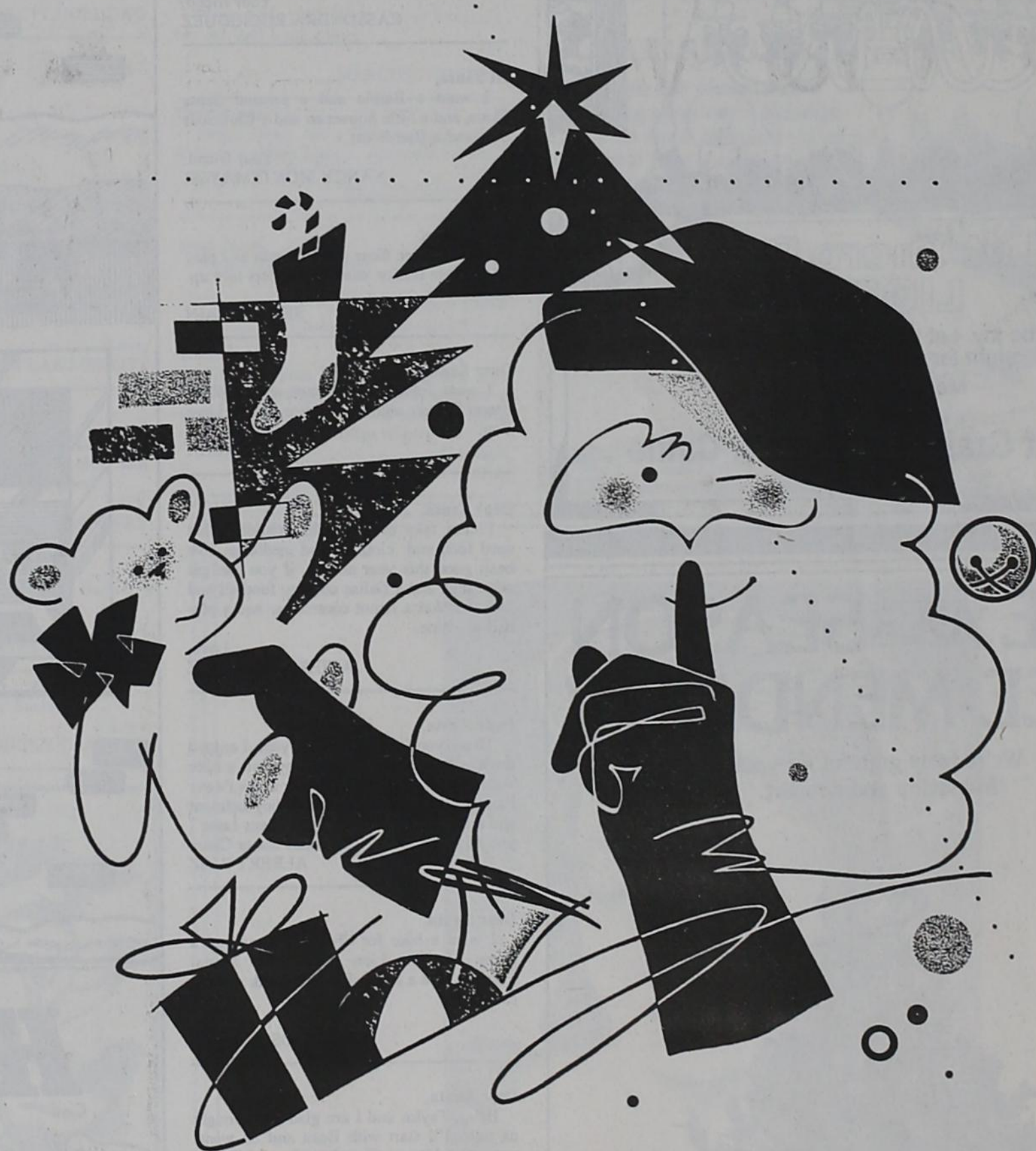

**MERRY CHRISTMAS**

**The Word Is Out...Warm Wishes Are In!**  
Hope this season delivers an abundance of joy, to all our good patrons and each girl and boy. We appreciate your valued patronage.



**DIMMITT BRANCH**

215 W. Bedford • 647-2265





anh

Dear Santa,  
I like you Santa. How are your elves? I want a bike for Christmas. I would like a bed and a Christmas tree. My buddy's name is Dustin and he wants a Happy Christmas.  
Love,  
SARA REYNA

Dear Santa,  
I share my toys. How are your elves? I would like a horse, a collection of dinosaurs and a steel tech. My buddy's name is Gerardo. He wants a basketball and a car. He also wants everybody to have a Merry Christmas.  
Love,  
TYLER WAGGONER

Dear Santa,  
I hav cukes ridy if you get so hgrc. Santa I wot two thexs. I wot a pawor rachrs and a game.  
Love,  
CESAR MEJIA

Dear Santa,  
Have I been good? I hope I have been good! I want a TV for Christmas. If I have been good please get me a TV.  
Sincerely,  
TABITHA LAURENT

Dear Santa,  
I have been a good girl. How are you? I want a doll and a My Size Barbie. I also want a baby crb. My buddy's name is Edward. He wants a video game.  
Love,  
KEMBRA ALBRACHT

Dear Santa,  
I am nice to my mom. How are you? I want a barbie car, a doll with a telephone, and some boots. My buddy's name is Nadia. She wants clothes.  
Love,  
FLOR VEGA

Dear Santa,  
I've been a good girl. Would you please come to my house. I would like a barbie, teddy bear, a girl Power Ranger, a big Barney, and a brand new computer. My buddy Veronica wants a new pick-up.  
Love,  
OLIVIA VEGA

Dear Santa,  
I am nise. How are you? I want a black Power Ranger. My buddy's name is Gerardo. He wants a B-B gun.  
Love,  
GEORGE CHAPA

Dear Santa,  
Haw is Mes, Clos. I will hav cooces on the tabo. Pless cud you brenng me a dansen brbe and a swemcn brbe.  
Love,  
JESSICA ORTEGA

Dear Santa,  
I have tried to be good and I have so far. So would you bring me a game gear and a talking doll house and I would really appreciate it if you would bring my little sister a doll, please.  
Love,  
ROXANNE OLTIVERO

Dear Santa,  
I have been a good girl this year. How are your reindeers? For Christmas I would like a barbie car. My buddy's name is Elissa. She wants a puppy.  
Love,  
CYNTHIA GUTIERREZ

Dear Santa,  
I can't wait to see you. How is Ms. Clus? I want a gameboy. I want a reindeer. My buddy's name is Roy. He wants a Happy Christmas for everyone.  
Love,  
ZANE FARRIS

Dear Santa,  
Pleas gev me the pink and yellow power rاجر. Hay is Mrs Claus?  
Love,  
KRYSTAL MARTINEZ

Dear Santa Claus,  
I've been a little bad girl, but can you please bring me a doll and a bike and clothes?  
Love,  
KENDRA MARTINEZ

Dear Santa Claus,  
I've been a good boy. So I want a G.L Joe and a B.B. gun. Thanks a lot.  
Your friend,  
EZEKIEL CALDERA

Dear Santa,  
I am nice to my cousin. How are you? I want a pool table. I would also like lots of toys, and a remote control car. My buddy's name is Christina. For Christmas she wants lots of clothes and friends.  
Love,  
FELIPE RAMIREZ

Dear Santa,  
Pleas bring theas theadgs a doll and a pair of chous. The bayby Im tokn abouwt she ses hello I have bin wating for you. And a big play hous. And a stuft rader and a stuft sant bear. I hope you and mrs claus are ding ok. And your raders to. A tint to.  
Love,  
BRITTANY WILLIAMS

Dear Santa Claus,  
I was sort of bad this year and I only want three thing this year: Nintendo and new shoes, but I really want a happy family.  
Love,  
CYNTHIA BARRERA

Dear Santa Claus,  
For Christmas I want a new bike and a sockerball. I also want a basketball and a baseball bat. I need new glasses, and the 6 things I need a shirt and a beck pack. I need a coat and a happy christmas to all. Thank you.  
JOHN LUCIO

Dear Santa,  
I am nice. How are you Santa? i would like a Sega. I would like a dallas helmet and a white Power Ranger with a dinosaur. My buddy's name is Abel. He wants a Oilers helmet.  
Love,  
JOEY MARTINEZ

Dear Santa,  
Houw are you doowing in the North Pole? I will hav sun cookes. Dear Santa pees wood you brenng me A bike and a sled and a trample.  
Love,  
MARTIN ALVAREZ

Dear Santle Claus,  
I know I've bad this year, but I ask for forgiveness. For Christmas all I want is a Happy Christmas! Let everyone be happy on Christmas! Please give Mrs. Merritt whatever she deserves whether it is a lump of coal or anything else.  
Love,  
KYLE RAY

Dear Santa Claus,  
I want for Chirstmas is a game. And a cap. And some clothes.  
Love,  
ALEX CASTILLO

Dear Santa,  
I have been a good boy. How are your elves? I want a bike and a Power Ranger for Christmas. My buddy's name is Ricardo. He wants to have a Happy Christmas with his family. He also wants a Dodge Viper.  
Love,  
ERIC RAMIREZ

Dear Santa,  
We will make you cookes. Tel Mrs, Claus too come weth you bec cus yo will eat cookes. I wood like rainger, 2 things a wite raiger sord and a megersord.  
Love,  
JONATHIAN SCTT FLORES

Dear Santa Claus,  
How are you and the Elivs and miss. Claus? I want to tell you I want a computer with a mouse-pad and mouse and head phones and computer-power and a Sleigh and a picksher's of Rudoph and the Elivs all over the house. I hope all of the reindeer's are ok to come all over the world. I will decorat the house. Merry Christmas to all my frids. HO! HO! HO!  
love you Santa,  
ASHLEE NINO

Dear Santa Claus,  
I want a smart play computer and a piano that shows you how to play it. I also want some cool cool clothes, And our family to stay together.  
Love,  
DEIDRE PEREZ

Dear Santa Claus,  
I want a new bike and a remote control car. And I would like a new money bank.  
Sincerely,  
REY MEDRANO

Dear Santa,  
I will leav coockcas for you. Pleas gev me the pink pouradrc.  
Love,  
VANESSA CABALLERO

Dear Santa,  
How are the elfs? Are they fine? Santa, I love yow Santa and Mesis Clos. I wut all the parrajr's. ustep the yellow and pink.  
Your friend,  
FRANK DE LA PAZ

Dear Santa  
i wont a miye sis bride barbie. And a drem lad babea. And a tv for christmas.  
Love  
Rebecca Bryan

Dear Santa Claus,  
I was pretty mean this year, But I want a football and roller blades. But most of all I want my own t.v. and v.c.r.  
Your friend,  
NICKY GAUNA

Dear Santa,  
Whel yow prtee ples breg me a robot? Houw is yr reindeer?  
Love,  
CHRIS SAENZ

Dear Santa,  
How is your reindeer? How is mesis clos? How is the efes? how is the North Pole? Ples gim a jep and I wot a jemejnask and klos and shos.  
Luv,  
JENNIFER MONTES

Dear Santa,  
Please bring me a big doll, an apple, and an orange.  
Love,  
TABITHA VELASUMY



## God Bless You All

We wish you great joy at this time of year.  
May this be your happiest Yule ever!

**Dimmitt Welding & Electric**



## Away In A Manger

*Just as the angels came to spread the word, we'd like to spread our best holiday wishes to you and your family this season.*

*Blessing to all with sincere thanks.*

### El Sombrero Restaurant

Floyd Lopez and Son

Dear Santa Claus,  
My name is Christy. I tried to be good this year. This is what I want Secret Talk Betsey, a toy train, and a Barbie car. Please bring Mrs. Merritt, my teacher, a pair of cool sunglasses and a good year. Please bring my sister a doll—any doll.  
Love,  
CHRISTY MORGAN

Dear Santa,  
I hope I have been good enough this year so I can have Sega Game Gear, T.V. with a vcr, and some clothes. I Love you Santa, Oh, and thank you for the 12 speed bike you brought me last year.  
Love,  
MEGAN FIGG  
P.S. We will make you some chocolate chip cookies. And save some for Mrs. Claus.

Dear Santa Clues  
I was sort of being bad but if you could bring me a lethur jacket, light shoes, cloths, one more thing a makeup beauty doll thanks a lot I hope you could give it to me for Christmas.  
Sincerely,  
ERIKA MENDOZA

Dear Santa,  
What I would like for Christmas is a sega, skateboard, hom, Power Rangers. So If I'm good please send me that.  
Love,  
FABIAN LOPEZ

Dear Santa Clause,  
I have been a good boy this year. i want you to bring Daddy home from the Navy ship so Joshua Skyler and I can play with him. I also want a green Power Ranger and a Power Ranger game a race track and a Lion king game.  
Love,  
ZJHON SMOTHERMON

Dear Santa,  
I wawnt a polly pocket and a my size barbey and a medium dog and a computer and a rabbit and a cat and a ubrella an a dress with cake a roses and a zibra and a horse thats all.  
Love,  
KATHY AMDOR

Dear Santa,  
I want a power ranger that moves all by himself. I also want a ninja turtle that goes with a car. thank you Santa.  
RAMON RIVERA

Dear Santa Claus,  
I've been a little bad girl. Could you please bring me Nintendo, a doll stoller, new shoes, a book of Christmas, but I really want a nice family and a happy family. I hope you will come to my house.  
Love,  
MARCELA SALINAS

Dear Santa Claus,  
I have tried to be good And I am hoping you will come and put toys and other things under my tree this year. I want a pretty necklace and a T-shirt with jeans to match. If you can bring Mrs. Merritt a necklace, too please!  
Love,  
LISA SEARS  
Merry Christmas!

## Merry Christmas

(And Thanks A Plenty!)

We're grateful for your abundance of support.

### Garner Ball Photography

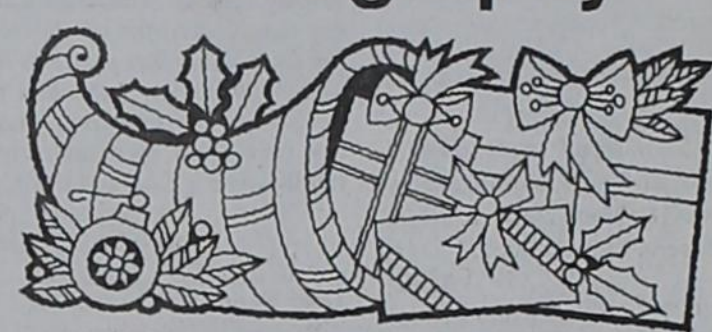

## TO OUR "BEST" MANY FRIENDS



We're pulling for you to have a simply splendid season.  
Happy Holidays!

### Tots and Teens



# Merry Christmas, Pardners!

Santa may be from the North Pole, but he's rounding up his reindeer to wish all of you cowpokes a rootin', tootin' Christmas!

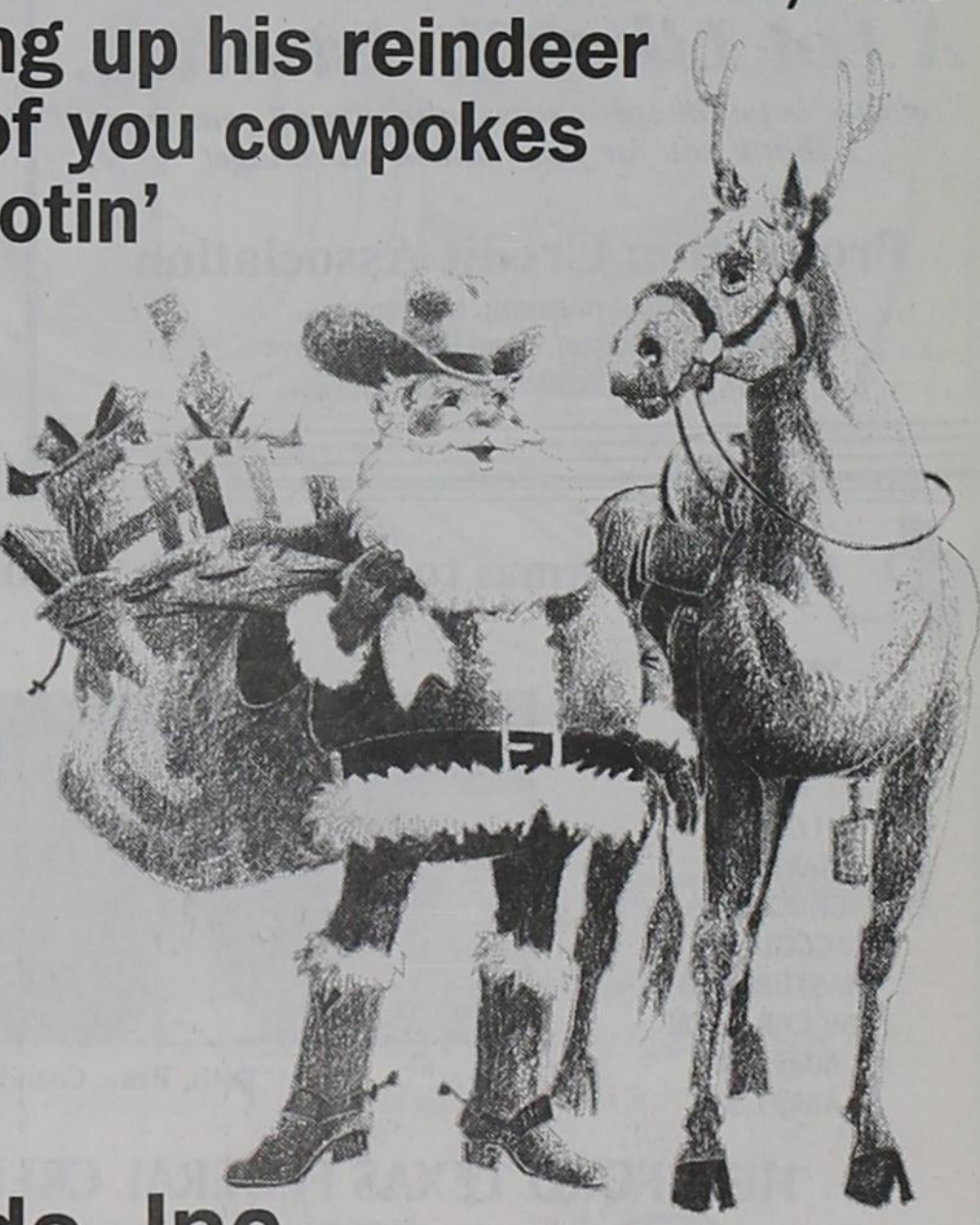

Thanks for your continued patronage.

## Dimmitt Feed Yards, Inc.





# a LITTLE and a

**Dear Santa,**  
I am in Mr. Soliz' second grade class. I have been a good student. I want a Harley Davidson and a power Ranger toy.

Love,  
Jose Lopez

**Dear Santa,**  
I am in Mr. Soliz class. I am in second grade class. I have been a good boy. I want a computer, all the power rangers, a Lion King Nctedo.

Love,  
Elias Zepeda

**Dear Santa,**  
I am in Mr. Soliz' second grade class. I have been a good citizen. I want a power Rangers for Christmas, and a Ricochet. I hope you have a good Christmas.

Love,  
Cory

**Dear Santa,**  
My name is Fabian Pena. I am in Mr. Soliz' second grade class. I have been a good helpful friend. I want a nerf football and a clothes and a new pair of shoes and a white power rangers. I hope you have a nice Day.

**Dear Santa,**  
I am in Mr. Soliz' second grade class. I have been a good student. I want a Harley Davidson's semis trailers. And a Notre Dame football for my brother and I.

Love,  
Rudy Salinas

**Dear Santa,**  
I have being a good boy can you bring me a Dirt bike, game gear, white ranger, Sega, 4 waceler.

Love,  
Matthew Larra

**Dear Santa Claus,**  
I wish you would bring me some clothes for school and also a Barbie that could ride the bike and a doll that does exercises. Also a computer, a rabbit that is soft. Also a T.V. with a VCR. I hope you have a Christmas Day. I hope you get presents and your wife gets presents too. I hope you get the presents to your elves.

Your friend,  
YVET BEANES

**Dear Santa Claus,**  
I want a bull dog that is a toy and a play toy soldier. The last thing I want is a football and a candy cane. I want a power ranger and his name is Tommy. The white ranger and my best thing I want is a sega.

Your friend,  
SAMMY

**Dear Saint Nicholas,**  
I am an 8 year old second grader. I want a doll for Christmas. And all kinds of Barbie dolls to go in my collection. and a football to play football with. And a better crop for my family. And the whole collection of the pet shop. And roller skates to skate with, and some new clothes. And a new pair of loafers. And a new horse to ride when I go out to my farm. And some extra money for my family. And a T.V. and a V.C.R.

Love,  
D'NEISE MICHIELLE SMITH

**Dear Santa,**  
I want a panther's football. I want a trapper keeper. I want a Dallas cowboy jersey number 88 and 80. I want a game. I want a new bike. I want a computer. I want some new shoe.

Love,  
Christopher Casas

**Dear Santa,**  
I am seven years old. I hope you can come to my house. I will give you some cookies and milk. I will be 8 years old in July. I would like a kitchen set, a camping girl and boy and a Barbie house. I also would like a pink Power Ranger.

Your pal,  
JENNIFER

**Dear Santa,**  
I want a football for Christmas. And I would like to have a blue truck. Also, I would like a bus. I would love to have a real dog to play with. also, I would like a toy red elephant and a tiger. It would be fun to have a reindeer.

ABEL AVILA

**Dear Santa Claus,**  
I want a green car and truck and money and a castle and a wolf and a bull dog and a killer dog and a lepricon to give me his gold. And I want you too and dasher. So you can take me to the clouds And I want a cheetah to take me home. And a want my own t.v. and a game gear and a super Nintendo and elves to make me anything I want.

Your friend,  
RENE GONZALES J.R.

**Dear Santa,**  
I want a bike, saga, power ranger, pool table, donkey kong game, boots, clothes, power ranger game, something for mom and dad. And that is all.

Love,  
Matt Calderon

**Dear Santa,**  
I want a Super Nintendo football game, hockey game, clothes and cars.

Love,  
Omar Pena

**Dear Santa,**  
I hope you can bring all these things. I am seven years old and my birthday is April 3rd.

Can I please have a bike, Don't Spill the Beans, Ants in the Pants, clothes, and roller blades?

Your friend,  
ADRIENNE HART

**Dear Santa,**  
I am 8 years old. I have been good this year. I am in the second grade. I hope you can bring these presents to me. The presents I really want are my size Barbie, the one with the pink dress. I also would like some Barbie skates.

Your friend,  
SANDRA MENCHACA

**Dear Santa,**  
I listen and learn a lot of things. You are nice and kind. Could you please bring me a white Power Ranger mask? I would also like some Reboks. The Communicator watches would be nice for me and my friend. My sister needs a bike. My family would like a Gameboy.

Your friend,  
JUSTIN CHAVEZ

**Dear Santa,**  
For Christmas I will want a Christmas tape of Rudolph and the Elves. I want a computer, Power Ranger shoe laces, and lights that blink and my brother will want a Game Boy. I would also like a puppet that talks.

Your friend,  
OLIVIA FLORES

**Dear Santa,**  
Can you give me a Power Rangers video game, Power Rangers dinosaurs, Pink Rangrs cap. Pink Ranger and Saba Sword.

Your friend,  
SOFIA FLORES

**Dear Santa,**  
How are you? I am fine. our names are Quentin and Ramiro. I want for Christmas a go-cart, a red power ranger, a black power ranger, a blue power ranger. Ramiro wants a new car, more clothes, a BB gun, a pet rabbit and a stereo with a CD player. This is all I want for Christmas.

Love,  
QUENTIN MALONE  
RAMIRO VEGA

**Dear Santa,**  
My name is Vanessa Mendez. I am 7 years old. I live in Hart Texas. I would like a barbie house and also a computer. Please bring my friend Enriqueta Vela a teddy bear, motion ring, clothes, maroon jacket, stereo with a CD player and a T.V. for her room and a VCR and Santa I love you.

Love,  
VANESSA LOPEZ  
ENQUETA VELA

**Dear Santa,**  
I am seven years old. I have been good this year. I liked the stuff last year. I will give you chocolate milk and cookies this year, I hope.

I would like The Lion King game. I also would like the anamaniac game, a jambox, some Pet Shop things that I don't have now, and some roller blades.

Yours truly,  
AUBRA McREYNOLDS

**Dear Santa,**  
You are so special to me. I would like to have a stereo thats if I be good. My brother and I might leave you some cookies. I would like a phone but I just forgot how much it cost. Just don't spend all your time getting all of my stuff redy. I would like a T.V. and a V.C.R. but you don't have to bring it.

Love,  
MARSELA MORALES

**Dear Santa,**  
Are you coming this Christmas? What are you going to bring me? wake me up when you get to my house. If you are real give me candy and cookies. When you get to my house give me a T.V. with a V.C.R. and lot of toys. Name me your reindeer. I'm going now.

Love,  
JOSE GALVAN

**Dear Santa,**  
I wish for a Nintendo and a race car. How are you today? I wish for a TV and a Sega Genesis and for candy canes a cd playr a TV remote control, a nice teacher when I pass to third grade. And for a computer.

Love,  
SERGIO

**Dear Santa,**  
You are so special. I love you so much. I would not be silly for you. I want a doll and a t.v. and a stereo and a Sage and a dog. I have a nice teacher.

Love,  
YESENIA

**Dear Santa,**  
I want a barbie doll house. I also want a dog that walks and some rollerblades. My friend Melissa would like some clothes, a waterbed, and some cassettes or CD's. I want a rabbit. Melissa is in the 10th grade. Melissa and I would like some jewelry. We have been pretty good this year. We will leave you some cookies and milk.

Love,  
VANITY WASHINGTON  
MELISSA ETHRIDGE

**Dear Santa,**  
I would like a barbie doll. I would also like some crayons and paper. I would also like a water bottle. I would like a Jumpsey and a kite to play with. Kandee would like some clothes and a watch. Kandee would like a nice looking boyfriend.

Your friend,  
KANDEE GROSSMAN  
MIRANDA PRICE

**Dear Santa,**  
I want a baseball bat. I want a pool table. I want a soccer ball. I want a big football. I want a nintendoe and sonic and nuckles. I want a new backpack. Josh wants a new car, Entertainment center, and a huge water bed.

Love,  
ADAM ROSAS & JOSH

**Dear Santa,**  
I want a barbie, a barbie car, a radio, and a small tree. Mrs. Elam, my friend, wants some books. We have been good. We hope you have a Merry Christmas.

Love,  
EVONNE VELASQUEZ

**Dear Santa Claus,**  
I want a elves and a big gun toy and a football to play it. I like a nike shoes like Sammy. I like a power ranger people toy the red one. I'd like a hat that is black my pants and a shirt. Id like 7 little toy cars. I'd like a box of candy.

Your friend,  
HOMERO

**Dear Santa,**  
I want a boy puppy, and I want the lion king animals. And I want a Sega and I want a Barbie and I want a baby doll. and I want a candy cane and I want a toy truck. I hope have you a Merry Christmas.

Your friend,  
KELSEY

**Dear Santa Claus,**  
I want a bike for Christmas and a cat toy and a snowman toy and some clothes to wear and a supermiendo and a Barbie doll and a dog toy and a stocking full of cany in it and a Christmas tree. And I will give you a present and some pretty shoes and some pictures and some money like 10,000 and a clock.

Your friend,  
VICTORIA

**Dear Santa Claus,**  
I want \$3,000.00 and a shecp dog. A computer and I martian and marter also I want a lion king game. A rabbit, game genie, AARDVark, checkers, boats, cards, pinball and the last thing I want is a pet fish.

Your frind,  
JAMIE

**Dear Santa,**  
I want a doll that talks and some loafers and a super nintendo and \$900.00 for Christmas. I wish I get everything I want for Christmas. And I wish you a merry Christmas.

Your friend,  
JENNY

**Dear Santa,**  
Barbie Doll, cat, picture Barbie folding fun house, bird.

DARCY SCHULTE

**Dear Santa**  
How do you feel. I want a football. And a watch. I want a jacket a good jacket. I want a puza. I want some swings. I want a cap. I want a book.

love

Jr. Limas

**Dear Santa,**  
I have been a good girl this year. I want these things. A My size barbie, hundred dollars, stretch limo, manchin, to be rich, ford mustang, town of my own, puzzles, candy, gum, store, swimming pool, pets. thank you.

Love,  
Maribel

**“He prayeth best who loveth best all things both great and small.” Samuel Taylor Coleridge**



We thank you for the many "great and small" kindnesses you've shown us. We join our prayers with yours for peace and joy throughout the world.

**Nazareth Feed & Supply**



**Season's Greetings**

Thank you for putting your trust in us.

**Jones-Rawlings Insurance Agency**



**Take It Slow!**

We didn't want the occasion to pass by without putting in a word of thanks to our many fine friends. So sit back, relax and watch the good cheer come rolling in. Merry Christmas!



**Hill Land & Cattle Co.**  
Hart



**To Our Many Dear Friends**

Christmas has come 'round again and we hope you find yourself surrounded by lots of love and laughter. Our deepest gratitude to you, our customers, for your year-round support!

**Gerber Welding & Repair**

**Merry Christmas!**

To all of our friends and patrons we say thanks! Celebrate in style!

**La Coiffures**

118 S. Broadway, Dimmitt 647-5501



**It's Starting To Look**



**A Lot Like Christmas...**

And we hope the spirit stays with you all year long. Thank you for your valued patronage!

**Production Credit Association**

Ann Armstrong, Manager  
Mark L. Kleman, Loan Representative  
Edna Sanders, Secretary

Merry Christmas to all of you from your friends at

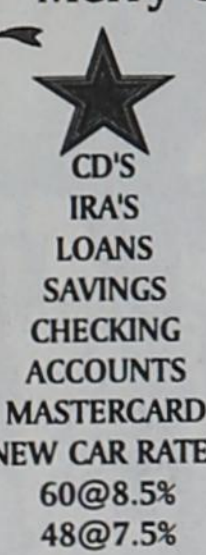

CD'S IRA'S LOANS SAVINGS CHECKING ACCOUNTS MASTERCARD NEW CAR RATES 60@8.5% 48@7.5%



Beth, Tresa, Chandra and Mike

**HEREFORD TEXAS FEDERAL CREDIT UNION**  
**DIMMITT BRANCH**  
212 W. Bedford • 647-5169

LET US HELP YOU WITH ALL OF YOUR FINANCIAL NEEDS  
MASTERCARD RATES: REGULAR 14%; GOLDCARD: 13%  
NO ANNUAL FEE



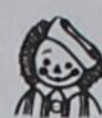
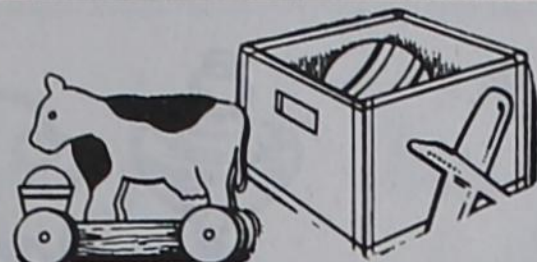
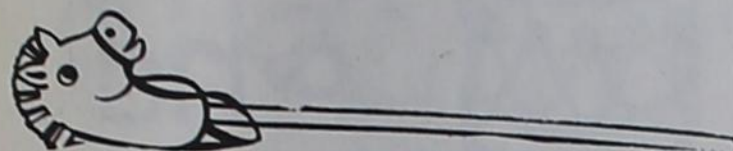

and a

**Dear Santa,**  
like a T.V. and a vcr and a bike and a Harley Davidson and a police car Some Clothes, Wagon, and Trucks, dog, car, farm animals toys, motorcycle, and a football, Please bring me a horse, socks, radio, CD player, video games, donkey kong, a new coat, air condition, new tires for my bike. Merry Christmas Happy New Year.

love,  
MANUEL CHIA

**Dear Santa,**  
I've been good all this year. Please bring me a Barbie Sitter Skipper and clothes to go with it. I also want my Mother and Father to have a good Christmas.

Love,  
ALEXANDRIA ROSE REYNA

**Dear Santa,**  
For Christmas I would like to go to Mexico and get my bike. I want to see my grandma also. Thank you.

ADILENE FERNANDEZ

**Dear Santa,**  
I want lots of toys. I want a Polly Pocket, a computer, a four-wheeler, a dishes, spiders, teaparty, a schnauzer, a tarantula, a Nintendo, a horse and a mouse.

Love,  
Dalila Longoria

**Dear Santa,**  
For Christmas I Want a Sega with games. I want a Polly Pocket. I also want a tea party set, some roller blades, and a television. I would also like to have a doll stretcher, the movie of *The Lion King* and the stuffed cub. I would like new clothes and new shoes size 2. I would also like a watch, a calculator and a new game of the Power Rangers.

Love,  
Mariza Mendoza

**Dear Santa,**  
I want a computer and a Sega Mortal Combat game. That's all.

Thank you,  
Marcus Reyna

**Dear Santa,**  
I Want a bike or some skates. I wish you a Merry Christmas. Christmas is the best holiday of the year. Thank you.

Your friend,  
Nellie Torres

**Dear Santa,**  
I want a Sega cd, a dog, and a cat. I want a horse and saddle, a horse pen to put it in, some Sega tapes and a cd, and a Barbie house.

Your friend,  
Gina Irons

**Dear Santa**  
I want a toy. I want a truck. I want a car. I want to geve my sistr a bere.

I Love You  
Roger Ramirez



**Dear Santa,**  
I hope you get a good sleep. I know where you live. I am 7 years old and I am being good. I want a white Tommy's Power Ranger mask and one for my little brother.

Yours truly,  
ANGEL BEANIS

**Dear Santa,**  
I am eight years old and I am in second grade. I want Power Rangers, Power Rangers video game, and Power Ranger clothes, Red Ranger watch, cap and a drangon.

Your friend,  
DAVID CISNEROS

**Dear Santa**  
I want a bike. How are you? My dad want a book.

I Love you  
Kelly

**Dear Santa,**  
I would like to have a Nintendo, some dishes, computer, a Polly Pocket, a schnauzer, and a doll that has a bottle. That is all I want.

Love,  
Elisa Herrera

**Dear Santa,**  
I would like to have a Super Nintendo and a football game to go with it. I would like to have a race car track that you can hang up on the wall and a little computer.

Sincerely,  
Jordy Rowland

**Dear Santa,**  
I would like to have a Super Nintendo and a Game Boy. I would also like a black bicycle.

Your friend,  
Ruben Espinosa

**Dear Santa,**  
For Christmas I would like the movie *Little Giants*, a Walkman, Magic Works, and some Legos.

Sincerely,  
Trent Barnes

**Dear Santa,**  
I would like to tell you what I want for Christmas. I would like a Barbie Bake Oven, Creepy Crawler Super Oven. I also want a keyboard a little T.V. that you could carry around. There are mor. ethings that I would like and they are a hand-pocket video game Polly Pocket, a sewing machine that put on diamonds and a book to see which decorations to put on it. That's all I want.

Your friend,  
Angelica Mata

**Dear Santa,**  
For Christmas I want a T.V., Polly Pocket, Sega, and Mortal Combat. I don't need any more. I wish you a Merry Christmas.

Love,  
Lupe Lujan

**Dear Santa,**  
For Christmas I Want a new bike a Sega. I want a computer to type on and color things and draw. Another thing I Really want is a Mortal Combat.

Love,  
Roy Robledo

**Dear Santa,**  
This year I Want a Troy Akmen's football jersey. I also want a go-cart. Finally I want a computer.

Love,  
Matthew Gonzales

**Dear Santa,**  
For Chrismast I would like a speed bike, a computer diary, some comquest computer disks and some clothes. Oh yea, and if you could fit in a couple of thousand bucks because I'm kind of short on cash. For my mom I want some cooking utinsills and some jewelry. For my dad I would like some tools, a new pickup and new pocket knife. For my brothers I would like a football, clothes and a house.

Sincerely yours,  
Maegan Farris

**Dear Santa,**  
I hope you have a nice Christmas this year. I want lots of things but I won't name all of them. I want a new bike, a big stuffed bear. Also a big stereo, a computer that is little that you can give a messages to your friends. Also I want a diary for Chrismas. That is about all I want for Chrismas. But I want everyone to have a nice Chrismas.

Love,  
Ashley Johnson  
Ps. give my Love to Mrs. Claus

**Dear Santa,**  
I want a Super Nintendo with two games. The two games I want are Mortal Kombat II and Troy Aiman Plays. I also want some cool roller-blades that are black. I want some football cards and a Garth Brooks and a George Strait cassette. I want a game gear game so I can play it. I want the game Splat also. I want a Dallas Cowboys poster for Chrismas.

Sincerely yours,  
A.J. Carrasco

**Dear Santa Claus,**  
For Chrismas I want a Scag, a pair of pink rollerskates, and helmet. The next thing I would like is a gymist Barbie. The third thing I would like is a two story houses. And then I would like a really surburber, a really truck. The realy thing that I Want bad is a jogging suit with the top. And then I want a diary with a key to go with it. Then a big cupter, a typewriter. The last thing I would like is a game boy with all kinds of games. Thats all I want.

Love,  
Julissa Marin

**Dear Santa,**  
For Chrismas I would like a bike, a three story house, skates, a gold car, toys, donkey, a saga, a t.v. a room with one computer and pretty flowers on the wall. Santa when you come to my house I will leave you some cookies and milk.

Your friend,  
Jessica Maldonado

**Dear Santa Claus,**  
For Chrismas I would like to have a game boy games for the game boy, Ask Zander a game, a new bike, books, colthes, rollblades, a computer, games for the computer. I would like a diamond ring for my mom. I would like a new pickup for my dad.

Love,  
Ashley Martinez

**Dear Santa Claus,**  
For Chrismas I want a T.v. set and a super nintindo with the Power Rangers game to go with it. I want a basketball and a basketball goal and Nikes shoes for my little dribblers game. I want a Dallas Cowboy jacket and a Cowboy cap.

Sincerly,  
Chris Rodrigez

**Dear Santa,**  
This year for Chrismas I would like a pair of rollerblades, a hand-held game, a pair of black Sunday pants and black boots, a radio control car, another nintendo gam, and some more tractors and plows.

Sincerly,  
Russell Miller

**Dear Santa,**  
For Chrismas I want a real cat and a tv. How is your wife? I also want a thousand dollars and a car for my mom and dad. And that's what I Want for Chrismas.

Sincerly,  
Aarica Ortiz

**Dear Santa Claus,**  
For Chrismas I want a big present and I want a Super Nintindow with Mighty Morfin Power Rangers. And Street Fighter 2. And I want a two game boys for me and my brother and I want 6 games that come with the game boy.

Love,  
Joshua Reyna



*"What child is this, who laid to rest,  
On Mary's lap is sleeping?  
Whom angels greet with anthems sweet  
While shepherds watch are keeping?  
This, this is Christ the King."*

Wishing you a special  
Christmas Blessing.

**Westex Federal  
Land Bank Association**

# JOIN THE PARTY!

Many believe,  
That Christmas Eve,  
Is cause for glee,  
Next to the tree,  
With mistletoe,  
A fiery glow,  
Plenty of friends,  
And fun without end.

**Merry Christmas!**

Enjoy the holidays with us! Our lounge will be open until 10 p.m. on Christmas Eve.

**Country Club of Dimmitt**

## Wishing You Good Times Aplenty

Go ahead and enjoy everything the season has to offer -- an abundance of good friends, family, food and fun for everyone! Thanks to one and all for bringing us so much joy!

**Tidwell Spraying Service**

## Hope Christmas Brings Nothing But Good News!

We're happy to report that Christmas is almost here, and we'd like to deliver our best wishes for a joyous season to all our readers.

Happy Holidays  
From  
**The Castro County News**



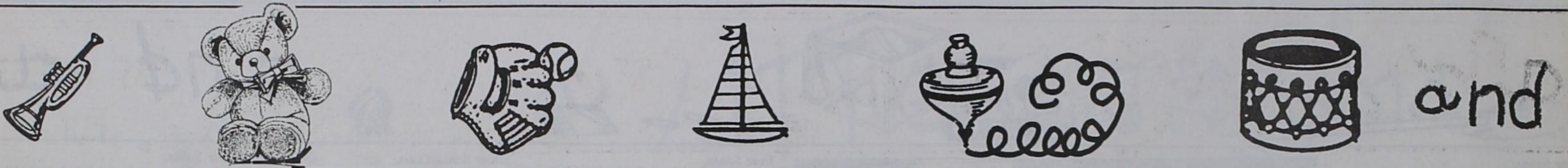

Dear Santa Claus,  
For Christmas I want a Game Boy, Computer, Super Nintendow and another Computer that can help me with subtraction. And that is what I want for Christmas.  
Love,  
Kathleen Diaz

Dear Santa,  
How have you been this year? I have tried to be good. Could I have a singing machine with two microphones. Also, I want a basketball arcade game. Have a nice Christmas.  
Love,  
Daniel Coleman

Dear Santa,  
Hi! How are you doing? I am doing ok. I hope you don't get too tired delivering all the gifts this year. We just read a book called Polar Express today and I really like the part of the story when the elf gave the bell to you and you gave it to the little boy. And I would like to have a bell just like the one in the book.  
I have a pretty long list of stuff that I want for Christmas. I won't put it all in this letter, because it would be too much for the newspaper to print.  
What I really, really want is a go-go walking dog, a bike, a doll that you really feed, a Precious Moments Bible, a wedding Barbie doll, a long pretty coat a toboggan, and scarf to match, a calculator to practice my math and all the different flavors of Chap Stick, a nicer big brother because mine picks on me an awful lot and for my big sister to get well because she's sick a lot. I really want my maw maw and pawpaw and my Aunt Sissy and Mark and Jetina to be able to come for Christmas Eve, too. And I'd like to have a picture of you, too, Santa.  
If you can't bring me everything I will not be upset!  
Love you,  
Chelsia Young-Scroggins

Dear Santa,  
I am excited about Christmas. I know that you are watching. I have been good this year. For Christmas I would like a race car and a puppy. Please be sure to leave a gift for every boy and girl around the world. I will leave milk and cookies for you.  
My favorite reindeer is Rudolph.  
Your friend,  
Beau Gonzales

Dear Santa,  
I want a Barbie doll, Barnie, doll house with a baby that talks and rollerblades. Thank you.  
Love,  
Krystal

Dear Santa,  
I want a doll.  
Carly Gilbreath

Dear Santa,  
I want a pretty long list of stuff that I want for Christmas. I won't put it all in this letter, because it would be too much for the newspaper to print.

Dear Santa,  
I am excited about Christmas. I know that you are watching. I have been good this year. For Christmas I would like a Harley-Davidson bike and a black helmet. Please be sure to leave a gift for every boy and girl around the world. I will leave milk and cookies for you.  
Why do you always ride in a sleigh?  
Your friend,  
Wesley Nutt

Dear Santa,  
I want a stereo and some tapes that are Mikel Jackson, Dangers, Jim Morgral, John Mickel Momgumrey, and Ace of Base. I also want a new 18 speed bike. I saw some plows from the John Deer house that are a hamicy with a treter and a grain buggy. A walkman and 1 or 2 tapes. I want these games for my Game Gear: Mortal Kombat II, Sonic the haghog, Street fighter II, and World Series Baseball.  
Your Pal,  
Zachary Jones  
P.S. if you can find it all I would like it.

Dear Santa,  
I want a doll named Christen with brown hair. Also I need clothes for her.  
Cailee Gilbreath

Dear Santa,  
I want a bike, and some SAGA games. I want a SAGA game that is called The Lion King, and Aladdin, and Sonic the haghog three, and Sonic the haghog two, and Sonic the haghog one, and Sonic the haghog. I want a Aliven Harper, Troy Aikman and Michael Irven poster.  
Sincerely,  
Shelby Aalbers

Dear Santa,  
I am excited about Christmas. I know that you are watching. I have been good this year. For Christmas I would like a horn and a skate board. Please be sure to leave a gift for every boy and girl around the world. I will leave milk and cookies for you.  
Bring my brother a skateboard.  
Your friend,  
Fabian

Dear Santa,  
I wish you could give me a Barbie and a bike so I can go around the park. I think I have been good with my mom and dad. I hope you have a nice christmas day.  
Love,  
Jessica Delgado

Dear Santa,  
I want for Christmas a doll named Molly with glasses.  
Chauncey Gilbreath

Dear Santa,  
Can you please bring me a bike and a remote control car? and Also Santa my sister Monic forgot to sent her letter to you. If you could bring her some makeup and a jumping rope. We will be very happy.  
Thank you  
Love,  
Casey Alaniz

Dear Santa,  
I am excited about Christmas. I know that you are watching. I have been good this year. For Christmas I would like a motorcycle and a Batman bike. Please be sure to leave a gift for every boy and girl around the world. I will leave milk and cookies for you.  
Please bring my sister a baby gun.  
Your friend,  
Rudy

Dear Santa,  
I want two camera. I want a Barbie that do excisse. I want a little bells. I want a boots size 4 1/4. I want a watch. I want a Plates. I want 2 Book of stickers. Dear Santa,  
Love,  
Maria Rodriguez

Dear Santa,  
I want a real football helmet, and a basketball jersey. Please bring my little sister Jill a pink power ranger and a baby doll.  
Love,  
Ryan Miller

Dear Santa,  
May I have a gameboy, and a nintendo, and a modercycle bike, and May I have the game pipe pipe tube. Merry Christmas Santa.  
Love,  
Michael Diaz

Dear Santa,  
I want a car so I can play with it and I want a TV and a xmen and a book.  
Love,  
Jorge Alvarado

Dear Santa,  
I want a barbey and a little barbey house and a toy.  
Love,  
Sonya Gonzales

Dear Santa,  
I want a three wheeler. I also want for my brother and sister to get what they ask for.  
Thank-you.  
Love,  
Matthew Ray Ruiz

Dear Santa,  
Thanks for the prescans you gave me last year. My sister Cathy want' some rollerskats. My brother Johnny want's a new Gocart. My brother Gabriel wants a bike. I want a doll that cries.  
Love,  
Angel maric Castillo

Dear Santa,  
I like a bike for Christmas and I like you Santa.  
Love,  
Rene Rodriguez

Dear Santa,  
I want a car for Christmas. I want a 10th speed. I want a big fot.  
Love,  
Jose Arredondo

Dear Santa,  
I want a Sega, 2 Super Nintendos, a Christmas Tree, all the Power Rangers and a Barbie for my cousin April. I also want a dirt bike. And two basketball goals.  
Love,  
Roy Sanchez

Dear Santa,  
I want a bike. I want a doll. I want a dollhouse. I want a wach. I want a recd plear. My broth wants a cat. My broth wants a dog.  
Love,  
Trish Reyes

Dear Santa,  
For Christmas I want a little car and shoes.  
Love,  
Rolando Ontiveros

Dear Santa,  
Sins i knew their was a Santa claus I was very Surprise that it was new For me because when i was little my mom tell me about you because when i behave bad bring any thing.  
Love,  
Jose Ledesma

Dear Santa,  
I would like the game Ask Zandar. And the game Perfect Match. I would like a big black Go cart and an Apple Computer. I would also like a super Nintendo and a black and white desk that's kind of little. And the game Wheel of Fortune.  
Love,  
Kami Sanders

Dear Santa,  
Thank you for the things you gave me last year. I would like a doll and a toy train. Do not forget the other boys and girls. Merry Christmas!  
Love,  
April Morgan

Dear Santa,  
I will like a bike and my brother JC. and my sister Amanda. I hope you get my letter Santa I wanta TV.  
Marry Christmas  
Love,  
Amy Carter

Dear Santa,  
I want a Sega, 2 Super Nintendos, a Christmas Tree, all the Power Rangers and a Barbie for my cousin April. I also want a dirt bike. And two basketball goals.  
Love,  
Roy Sanchez

Dear Santa,  
I want a Sega, 2 Super Nintendos, a Christmas Tree, all the Power Rangers and a Barbie for my cousin April. I also want a dirt bike. And two basketball goals.  
Love,  
Roy Sanchez

Dear Santa,  
For Christmas I want a Power Rangers then a new bike and a Ninja turtle can a new red toy car. I would like a Sega game. An a new control too.  
Love,  
Raul Olivera

Dear Santa,  
How are you? I would like a Barbie. I would like to have a nintendo game.  
Love,  
Rosalia Saenz

Dear Santa,  
I want a go kart. I want a trampoline. I want some clay dough. Thank you for giving me gifts last year. bring my moms twin for Christmas.  
Love,  
Apolonia Flores

Dear Santa,  
I would like a bear and a raido for Christmas pease and a co player. I hope you have a good Christmas to.  
Thank you  
Love,  
Maribel Rivera

Dear Santa,  
For christmas I want a barbie and a baby alive and a bike and cloths and a size barbie camping barbie and some earrings.  
Love,  
Rosalinda Jaramillo

Dear Santa,  
I would like a baby brother for Christmas. And I would like a Diary like my big sister's.  
Love,  
Yvonne Sifuentez

Dear Santa,  
Remember the things you brought me last year. This year I would like a bike and I would like it to be any color you would like and I want a super soaker 2,000.  
Love,  
Jose Ontiveros

Dear Santa,  
I would like a watch and some new clotcs for Christmas.  
Love,  
Delilah Barrios

Dear Santa,  
I would like for Christmas a big nintendo and a doll and a little house if you could bring me a litt car for me and I would like a baby doll.  
Love,  
Alejandra Velasquez

Dear Santa,  
I want some clotese for me. I like to have a dog, I Love you Santa. I like to have a homse. My mom is nice to me.  
Love,  
Marisol Fuentes

Dear Santa,  
I am very excited about Christmas. For Christmas I would like a doll and a ring.  
Merry Christmas Santa.  
Love,  
Rosina Ornelas

Dear Santa,  
I want a bike for Christmas and a toy boat and a Christmas happy day and a toy car for me and my brother.  
Love,  
Andy Sias

Dear Santa,  
I am very excited about Christmas. For Christmas I would like a Barbie and a ring.  
Merry Christmas Santa.  
Love,  
Susana Ornelas

Dear Santa,  
I want a barbie, and a barbie car, and some pants, and some shose, and a barbie house, and a doll.  
Love,  
Yadira

Dear Santa,  
Could you bring me a football and lots of toys for Christmas.  
Love,  
Jesus

Dear Santa,  
Santa I want a airplane and truck with control of battery and I want too that you can go to see to my sister for put toys to my sister big and my sister little.  
Love,  
Raul C.

Dear Santa,  
I would like a nintendo and a doll and a little house if you could bring me a litt car for me and I would like a baby doll.  
Love,  
Alejandra Velasquez

Dear Santa,  
I want a go kart. I want a trampoline. I want some clay dough. Thank you for giving me gifts last year. bring my moms twin for Christmas.  
Love,  
Apolonia Flores

Dear Santa,  
I would like a bear and a raido for Christmas pease and a co player. I hope you have a good Christmas to.  
Thank you  
Love,  
Maribel Rivera

Dear Santa,  
I want a bike for Christmas and a toy boat and a Christmas happy day and a toy car for me and my brother.  
Love,  
Andy Sias

Dear Santa,  
I am very excited about Christmas. For Christmas I would like a Barbie and a ring.  
Merry Christmas Santa.  
Love,  
Susana Ornelas

Dear Santa,  
I want a barbie, and a barbie car, and some pants, and some shose, and a barbie house, and a doll.  
Love,  
Yadira

Dear Santa,  
Could you bring me a football and lots of toys for Christmas.  
Love,  
Jesus

Dear Santa,  
Santa I want a airplane and truck with control of battery and I want too that you can go to see to my sister for put toys to my sister big and my sister little.  
Love,  
Raul C.

Dear Santa,  
I would like for Christmas a big nintendo and a doll and a little house if you could bring me a litt car for me and I would like a baby doll.  
Love,  
Alejandra Velasquez

Dear Santa,  
I want a go kart. I want a trampoline. I want some clay dough. Thank you for giving me gifts last year. bring my moms twin for Christmas.  
Love,  
Apolonia Flores

Dear Santa,  
I would like a bear and a raido for Christmas pease and a co player. I hope you have a good Christmas to.  
Thank you  
Love,  
Maribel Rivera

Dear Santa,  
I want a bike for Christmas and a toy boat and a Christmas happy day and a toy car for me and my brother.  
Love,  
Andy Sias

Dear Santa,  
I am very excited about Christmas. For Christmas I would like a Barbie and a ring.  
Merry Christmas Santa.  
Love,  
Susana Ornelas

Dear Santa,  
I want a barbie, and a barbie car, and some pants, and some shose, and a barbie house, and a doll.  
Love,  
Yadira

Dear Santa,  
Could you bring me a football and lots of toys for Christmas.  
Love,  
Jesus

Dear Santa,  
Santa I want a airplane and truck with control of battery and I want too that you can go to see to my sister for put toys to my sister big and my sister little.  
Love,  
Raul C.

Dear Santa,  
I would like for Christmas a big nintendo and a doll and a little house if you could bring me a litt car for me and I would like a baby doll.  
Love,  
Alejandra Velasquez

Dear Santa,  
I want a go kart. I want a trampoline. I want some clay dough. Thank you for giving me gifts last year. bring my moms twin for Christmas.  
Love,  
Apolonia Flores

Dear Santa,  
I would like a bear and a raido for Christmas pease and a co player. I hope you have a good Christmas to.  
Thank you  
Love,  
Maribel Rivera

Dear Santa,  
I want a bike for Christmas and a toy boat and a Christmas happy day and a toy car for me and my brother.  
Love,  
Andy Sias

Dear Santa,  
I am very excited about Christmas. For Christmas I would like a Barbie and a ring.  
Merry Christmas Santa.  
Love,  
Susana Ornelas

Dear Santa,  
I want a barbie, and a barbie car, and some pants, and some shose, and a barbie house, and a doll.  
Love,  
Yadira

Dear Santa,  
Could you bring me a football and lots of toys for Christmas.  
Love,  
Jesus

Dear Santa,  
Santa I want a airplane and truck with control of battery and I want too that you can go to see to my sister for put toys to my sister big and my sister little.  
Love,  
Raul C.



# and THAT is all I love.

Dear Santa,  
I would like a schnauzer. A schnauzer is a puppy. I also want a Giness and *The Lion King* and Animaniacs in Genesis. I also want a computer that I know how to work. I also want a Glide hockey. I also want the two suits at The Company Store. I also want a new purse. I want all the kind of White Diamonds. I also want every body to have a Merry Christmas. I also want you to have a Merry Christmas, Santa.

Sincerely,  
Kaci Lee

Dear Santa,  
For Christmas I want a remote control car with high and low speeds. I will want a gocart and Mortal Kombat II, Troy Aikman's Football and John Madden Foot ball.

Sincerely,  
Eran Castillo

Dear Santa,  
I want a trampoline and a chimney for my house and a new folder and a bell from your sleigh and a four wheeler and a swimming pool and a car for me and a new house and lots of money and presents for my teachers and a toy box and bikes for my sisters. Have a merry Christmas and say hi To Mrs. Clause.

love,  
Raul Barrios

Dear Santa,  
I would like a race car and a power wheel and I wish my dad would stay home.

Your friend,  
Tommy Jouett

Dear Santa,  
I would like a football and a race car and a baseball bat.

Your friend,  
Alex Ornelas

Dear Santa,  
Please bring me an Erector Master Builder set. I would also like a K'NEX set and a Rescue Police Lego set and a rescue Fire Station Lego set. We will leave you some milk and cookies to eat.

Sincerely,  
Matthew Sanders

Dear Santa Claus,  
I wish that I had a ten speed, guesturs game, a Dallas cow boy watch, a leather jacket, neckless with my name, Supermintoe, Aoperation, jury box, a ring with my name on it and a trampoline.

Love your friend,  
Delfina Marie Martinez

Dear Santa Claus,  
Did you have a nice summer? Tell Rudolf I like his nose because it's bright. I would like a spotted dog named Porkchop and remote controlled car. Give Mrs. Claus a kiss for me. Thank you very much.

BEAU GONZALES  
Kindergarten



Dear Santa,  
I want a barby because I like you. How are you? I want a jakit for my brother. I want a bike.

Love  
Samantha

Dear Santa  
I want a wardgun. How are you? and my little cusen wants a Barby. and my Brother wants a Bike.

Love  
Sergio

Dear Santa  
I want a truck. How old are you? How are the reader?

Love  
Ruben Rodriguez

Dear Santa  
I want a BATMAN. I want a povraysher. I want a BarBy for my SiSr. I have Ben good. how ar you Santa Clas?

I am seven years.  
Vincent

Dear Santa  
I want a Ana the Keasne It is a barbarby. How are you? I am going to give you sunting.

Love  
Ana Sias

Dear Santa  
I want a BrBe Santa Claus. I want a dol Santhta Claus. I want a Christmas tree new. I want a Ber Santa Claus.

love  
Lupe

Dear Santa,  
I wanta Sega cd and a remote control car. I want some Barkley shoes. I want a super soaker 1.000. I want a game boy with a game. I would like you to get my dad a brand new truck. I would like you to get Persephanie a doll. I would like you to get my brother John Henry a low rider pick up. I would like a race car track. I would like you to get my sisters some athletic shoes. I would like you to give my sisters a radio. I would like you to get Ramona some clothes. I would like a game gear with the game Donkey Kong. Thank you Santa.

Your friend,  
Joel Puente

Dear Santa,  
I wished that all my family got what they wanted for Christmas and I would like to have anything you want to give me thank you!

Merry Christmas  
Love,  
Vanessa Barrios

Dear Santa,  
I want a Barbie and a Ninendo. I want a Barbie so I can play with it's hair. I want a Ninendo so I can play with it. I like toys a lot. I like toys because they are fun to play. Don't think I just like toys I like my mom and shcool to.

Love,  
Veronica Agüero

Dear Santa,  
I want a remote car for christmas. My brother Fabian wants Mortal Kombat part 2. My other brother wants Mortal Kombat Part 2 too. my little brother wants a Sega. Mom wants something purple to put her cigarettes. Dad wants tools. My Aunt Lamar wants a new car. My cousin wants a toy. My other cousin wants a doll with a bottle. I will leave some cookies.

Sincerely,  
Samuel Cavazos

Santa I will like a cor.  
I luv you Santa,

ADRIAN

Dear Santa  
My name is Edwin. I wut a white power ranjer. My has numr is 304. An I wot a NiNtenbo.

I love, Santay,  
EDWIN HERNANDEZ

Dear Santa  
I want a cor. I want a Batman. I want a Ninendo. I want a truk. I want a bigfoot.

I love you Santa,  
GIOVANNI RODRIGUEZ

Dear Santa  
I wot a Pawr Rangr. Drar Santa I wot a car. Drar Santa I wot a bat. Drar Santa I wot a bike. Drar Santa I wot a cady. Drar Santa I wot a Ninendo. Drar Santa I wot a truk. My name is Fernando. Drar Santa I wot a bey. Drar Santa I love you,

FERNANDO AGUERO

Dear Santa  
Mi nomvre es Alejandra llo crier o dos-monas I dulses.

ALEJANDRA SILVA

Dear Santa  
I wut a Bore. My name is Teresa Sanchez I wut for my mom a desc. I wut for my dad a cmpr. I wut for my sist a Bore. I wut for my Bruh a lil dog. My hous numr is 709.

I love you Santa,  
TERESA SANCHEZ

Dear Santa  
My name is Lisa ples santa wot a bike. I wot a kite ples Santa. I wot a bed ples santa. I wot a tebo ples santa. I wot a book ples santa.

I love you Santa,  
LISA MARRUFO

Dear Santa  
My nome is Jaimee Esqueda. I like Christmas. I like Santa. I Want a bike.

JAIME ESQUEDA

Dear Santa  
I like a pink projr rajr. I like a borb. I like a swimming pulu. I like a bike pink. I like a bol pink.

I love you Santa,  
ALMA REYES

Dear Santa  
I wot a bike for Krizms. how are you santa? How are the reindeers?

I love you  
Humberto Aguilar

Dear Santa  
My brother wants boots I want cloths. My Mom want cloths. My Dad wants jips. My Birthday is Decembe 29, 1994. I Love you Decembe 8, 1994

Haidee

Best Wishes  
For A  
Healthy,  
Happy  
Holiday

Dr. B. D. Murphy  
and Staff

JOYOUS  
NOEL!

Here's hoping your holiday is filled with an abundance of blessings. Many thanks for bestowing your friendship upon us!

Kittrell  
Electronics  
103 E. Bedford, Dimmitt

It's That Time Of Year

Everybody here is really up for a terrific time with friends and family. And we hope the season brings nothing but good things for you, our valued customers!

Lane Dirt Co.

Here's To A  
CHRISTMAS  
Filled With Joy!

To everyone we wish a safe and happy holiday. Have lots of fun, but please don't drink and drive.

The 19th Hole  
Nazareth

A YULETIDE  
WISH

As in Bethlehem of old, may the heavens light your way and may you and yours experience peace and joy at Christmastime.

Pay & Save Foods  
Hart

SEASON'S  
BEST

May the magic  
of Christmas  
bring you and yours  
a happy holiday.

Many thanks for your patronage this year and best wishes for the new one!

Texas Corn  
Producers Board





# YULENIDE GREENINGS!

From the bottom of our hearts, we're wishing you all the trimmings that make for a tip-top holiday season. It's our pleasure and privilege to be a part of Dimmitt and Castro County. We hope you have a merry Christmas!

American Maize-Products Company



# WEST TEXAS Country Trader

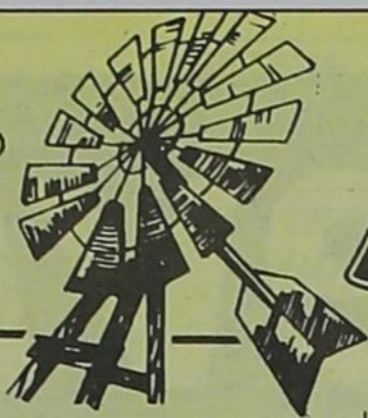

The West Texas Country Trader is a Supplement of:

Thursday, December 22, 1994

Abernathy  
Weekly Review  
The Canyon News

The Castro County News  
The Clarendon News

The Lorenzo  
EXAMINER

Plainview Daily Herald  
Ralls Reporter-News

The Slatonite  
The Tulia Herald



## Living 'cacti' Christmas tree

A one-of-a-kind living Christmas Tree at the Westin La Paloma resort in Tucson is made of more than 100 Golden Barrel Cacti. After the holidays these spiny desert dwellers will be nurtured on the resort grounds until next year.

## Ranch aglow with 600,000 lights, guides Santa through Hill Country

By RALPH WININGHAM  
San Antonio Express-News

BOERNE — The Christmas spirit twinkles and glows and sings across the back 40 acres of Jerry Hagee's Hill Country ranch, where 600,000 lights make up a backyard display gone super nova. Improving on last year's 500,000 lights and requir-

ing about eight miles of wiring and 3,000 extension cords, the Hagee family's four-month labor of love is called the "Follow the Star Christmas Lights" display.

It has become an international attraction just

See LIGHTS, Page 3 3



## Nicholas bear

Mara Wilson, star of John Hughes all new production of The 20th Century Fox holiday classic, "Miracle on 34th Street," introduces Santa Clause to Nicholas Bear, who also "appears" in the movie. Keebler Company made the bear available to consumers as a holiday promotion. The movie was widely acclaimed and continues through the holiday season.

## Quitaque eatery yields fajitas, ribs, good cheer

By GINA AUGUSTINI  
Lubbock Avalanche Journal

QUITAQUE — There's no blinking neon sign beckoning visitors to stop by the Sportsman Restaurant and Club, the West Texas version of "Cheers." In fact, there's no sign at all.

So how do people find this small town cafe and bar? "I have

See EATERY, Page 5

**TOMATOES**  
Organically grown and vine ripened in our greenhouse. No herbicide or pesticide. A healthy choice with great taste, 839-1107, 293-7656.

Professional Piano Works  
Tuning, repairing, restoring.  
Jewel resurfacing of Ivories.  
296-7846

LARGE TWO BEDROOM  
unfurnished apartments.  
Washer/dryer connections, fully  
carpeted, no pets. From \$350.  
Plainview Apartments, 293-2000.

Want to Rent wheat, stalks pasture for grazing or cattle. 293-3688, 293-3305.

2400 Sq. ft. office building, 7 offices, recreation area, 2 rest rooms, coffee area. Call Kirchoff Real Estate. 293-7542.

Tri-plex under construction. Owner financed. 23rd and Portland Street. Joe Baker, 293-0463.

Position available for Convenience Store. Manager/Supervisor, with experience and references. Send resume to Box B-10, c/o Plainview Daily Herald.

**CHRISTMAS PUPPIES**  
AKC English Springer Spaniels. Adorable. Black & white, seven weeks old. Parents on premises. \$150. Call 293-5523.

\*\*\*ADOPTION: Open arms, loving hearts await your newborn. We promise a lifetime of love, devotion and security. Also the loving relationships with a 3 year old adopted sister. Call Nadine and Chuck collect. 1-800-249-0155.

Three bedroom, two bath brick home, double garage with opener on 2 1/2 acres, well, outskirts of Silverton. \$58,900. Call Pat Ryan, Realtor, 293-2572 or 296-6288.

Buying Junk cars and scrap metals of all types. Daffern Steel & Supply, 201 South Date. 293-2609.

10 acres North of Plainview on I-27. Contact Alberto, 296-7736 between 6:00 & 10:00 Friday. All day Sunday.

40 miles from Plainview. 248 acres with large lake. Nice cabin & boat dock. Deep canyon. \$150,000. \$25,000 down - 20 years. Harry Hamilton & Associates, Realtors. 806-793-3366.

For Sale: Roods with parts. Woods Motor Company. 293-3688, 293-3305.

**BEYRWOOD**  
unfurnished furniture  
Do it yourself & SAVE  
#18 Briercroft Center  
50th & Ave. Q - Lubbock  
806 749-7979

**OVERWEIGHT**  
History of overweight,  
By- Pass, Surgery,  
Cancer, Etc.  
NEED LIFE INSURANCE?  
1/800-856-7340

## Working With Farmers For 60 Years

We Appreciate The  
American Farmer They  
Are The Backbone Of  
Our Nation. We As  
Always Will Continue  
To Give You The Same  
Great Quality Products  
& Service



Workmanship Counts

**Peerless Pump**

2211 Columbia District Office 296-5581

## RHODERICK IRRIGATION and ADAMS WELL SERVICE

Complete Irrigation Specialists

- Center Pivots • Sales & Service
- Service All Brands Center Pivots
- Irrigation Pipeline Installation



**PROVEN**

- Economical
- Reliable
- Accurate
- Portable
- SAFE

From the PUMP through the PIPELINE to the PIVOT,  
Call Us For Your  
TURNKEY JOB

LINDSAY  
ZIMMATIC

The Raining Champion

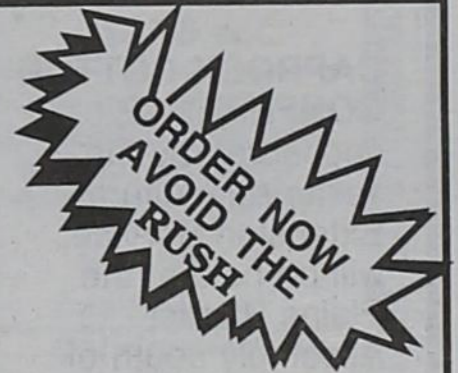
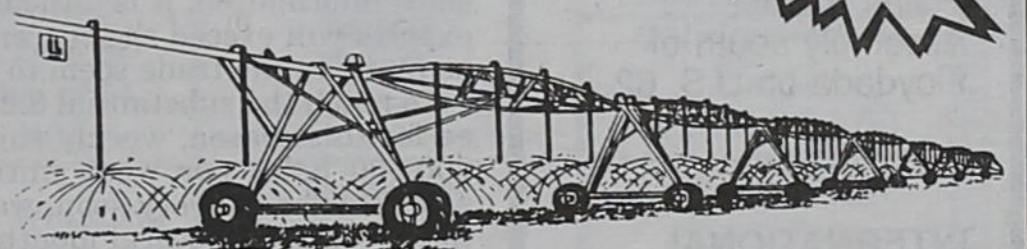

**UNDERGROUND PIPELINE** • Installed & Repaired

All sizes and kinds of pipe installed!  
Irrigation or Gas  
Now Available - 20,000 hour Pivot Light.  
We Service ALL Brands of Pivot Sprinklers.

**OUT OF TOWN CALL 1-800-878-2584**

823-2139  
Silverton, Texas

983-5003  
Floydada, Texas



# AgReview

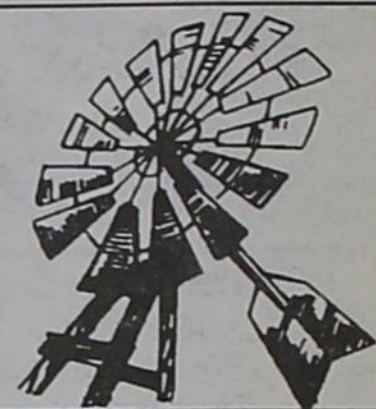

## Annual fruitcake frenzy continues at Corsicana bakery

By RICK KRETZSCHMAR

Corsicana Daily Sun

CORSICANA — While many businesses have experienced hard times in the recessions of the '90s, the Collin Street Bakery continues to thrive after almost a century.

"Recessions don't bother us that much," says president and owner I.W. McNutt. "We're better off without them, but we do well when they occur."

The company's most popular product is the Original Deluxe Fruitcake, and with Christmas approaching, business has been brisk.

The company that boasted of 20,000 pounds of product at the dawn of the 20th century is now producing four million pounds a year (33,000 pounds a day). It is now accepting 100,000 orders from outside the United States in every country except Cuba, Iraq and Iran. The business sends out 11.5 million pieces of mail (two million internationally) annually to promote the Original Deluxe.

But the business is also evolving at a pace that the bakery can handle.

In the '70s until the mid '80s, the bakery was increasing its output by 10 percent a year. While it has slowed down since then, McNutt says there will be a six-figure increase over last year's number of cakes.

"Our growth is slow. We don't want, nor can we accommodate, rapid growth. There are only so many fruitcakes we can bake," McNutt said. "But nothing bad has come out of the growth. We are a bigger, stronger, more viable company."

With the growth, 82 permanent employees now work at the bakery. But the activity around the bakery starts to explode in September, when thoughts around Texas are more along cherry snow cones than the cherries in the Original Deluxe.

Around 650 employees come to work for the bakery from September until January, due to international expansion.

McNutt said the international

business saw a boom from 1969 to 1971, when simple word-of-mouth spread the word about the fruitcake. In 1973, the bakery started to experiment with international mailings.

"It occurred to us that if we did this much business accidentally, how much could we do on purpose?" McNutt said. "We have built substantially since that time."

The growth abroad is affecting the growth in Corsicana. McNutt says that there should be an expansion of the main factory, which is 53,000 square feet now, within the next decade. The bakery's warehouse, which has been expanded three times in past 10 years to its current dimensions of 54,000 square feet, is nearing maximum capacity and also may have to be expanded.

So what's the key to all this expansion? Knowledge and careful idea implementation.

For instance, telex machines have been replaced with fax machines. McNutt says they receive 1,000 fax orders a day

and the four fax machines they have now are running nearly 24 hours a day.

And the bakery has an 800 number. This service, operated by a company in Phoenix, employs 40 people and is an example of the spill-over of job creation to other companies.

Besides the 650 people employed at the fruitcake factory itself, there are 40 more people employed at a computer processing center in Dallas, eight to 10 people in Dallas in an overnight processing plant in Dallas and 75 people in a pineapple processing plant in Costa Rica, making the fruitcake itself an international product.

"We started the pineapple factory four years ago," McNutt said. "We're continually expanding more and more 'hectares' as they call them."

"We're growing more pineapples than we can use, so we sell the balance to Dole, who exports it to the fresh fruit market in Europe and the United States."

Overall, the secret of the

Original Deluxe's success is being true to itself. The cake recipe has not changed in the past 98 years. McNutt contrasts that philosophy with another company's attempt to change a popular product a few years ago: Coca-Cola.

"They tried to abandon it, with very well known results and they were forced back to it with Coca-Cola Classic," McNutt said. "That was a real boner and they were smart enough to recover from it. The key to a successful product is don't change it."

So with a successful, delicious product (despite many fruit cake doubters this time of year) that is closing in on a century of excellence, what's next to promote it?

Don't expect anything radical.

"Radical is a bad word for us," McNutt said. "We gingerly test new concepts to prove themselves reliable."

"Everything that happens here is evolutionary, not revolutionary."

South Plains

## Ag News

Jan. 4-7

**BELTWISE COTTON CONFERENCE**, an event coordinated by the National Cotton Council, San Antonio, at the Marriott Rivercenter.

Jan. 17-18

**CAPROCK COTTON CONFERENCE**, sponsored by the Texas Agricultural Extension Service, will be held at the Plains Baptist Assembly south of Floydada on U.S. 62.

Feb. 23-24

**INTERNATIONAL LIVESTOCK** Congress, Sheraton Astrodome Hotel, Houston. Theme is "Positioning Beef in the Global Frontier." Registration information by calling Patricia Lee, Texas A&M University Department of Animal Science, 409-845-3808.

## Choppin' in high cotton: Price advantage of 1994 requires wise, strategic planning

Now we know why the "market was right" in moving up over 10 cents per pound in the face of a record 19.6 million ale crop. The rally was supported by cotton shippers "booking" 3 milling bales for export from this crop and 2.7 million bales from next season's crop. As a result, total use will also set a record that exceeds 19 million bales.

In the two weeks that ended Dec. 1, 1994, export commitments for the two seasons totaled a substantial 5.7 million bales. Shippers were in a "rush" to qualify for the 2.34 cents per pound user certificate value before they disappeared. But, they had been in the market preparing the sales since October. Meanwhile, the cotton can be shipped anytime before the end of Oct., 1995. Currently, user certificates are not available because the AWP (Adjusted World Price) has reached 65 cents per pound. The termination price level is 130 percent of the 50 cent 1994 CCC loan price.

The unexpected surge in export sales results mainly from poor harvests in Pakistan, India and several other foreign countries.

However, the large sales reported at one time may continue to cause erratic market behavior for a long time. Remember, these are commitments to export that include 1.7 million bales from this crop to "unknown" destinations, and the 2.7 million during next season.

These sales are not necessarily final until shipped. From the sales information, it is difficult to conclude that total 1994/95 exports will exceed the current projection of 8.2 million bales as many in the trade seem to believe.

To reach the substantial 8.2 million bales of exports projected for this season, weekly shipments need to average almost 200,000 bales per week until August, 1995. Because most sales are for delivery soon, weekly shipments may far exceed the average for several months.

A year with record cotton production, record use and a 10 cent price rally during harvest does not happen often. Enjoy it, but don't depend on a repeat market performance next year. Nonetheless, you can take advantage of the current price rally for another year by pricing next year's crop at this year's price level.

The cotton market faces unpredictable developments such as the final amount of 1994/95 exports, the size of next year's U.S. and foreign crops, worldwide policy developments, weather conditions, and the level of 1995/96 exports. Looking at history, sudden sales to China starting in late 1979, which eventually totalled 2.4 million bales, pushed exports that season to 9.2 million.

The market responded by a sharp rally in early 1980 that encouraged a substantial increase in planted acreage. The market weakened in early spring. But later, bad weather cut production, and the market raced higher until September, 1980.

Growers are planning to plant more acreage next year. The



## COTTON MARKET UPDATE

Dr. Carl Anderson

tentative 1995 ARP of 7.5 percent may be changed by January 1 to zero, down from 11 percent this year. And, 70 cent or so contracts are attracting "flex" acreage from grain. Acreage could soar to 16.0 million, up from 14.1 million this season. Texas farmers will likely increase cotton acreage planted some 600,000 acres, and the Delta and Southeast may increase at least 1 million acres from the level this year. The West may expand acreage by 200,000 acres.

Barring bad weather, a 21 million bale U.S. crop is reachable. Because of more foreign production and reduced demand from higher prices, usage might decrease to around 18 million. That would increase U.S. stocks by 2 to 3 million bales and push carryover to 6 or 17 million bales. The stocks-to-use ratio would be 33 to 39 percent. If this scenario unfolds, loan rate level market prices are not out of the picture. This potential supply build up would set the stage for a possible "price wreck" that you need to protect your flow against. Adverse weather, of course, could reduce production, and resulting tight supplies would support higher prices. Too, because of higher cotton prices, more synthetic fibers may be used. China, for example, is rapidly increasing production and use of man-made fibers.

A price drop in December, 1995 futures by harvest next fall from the current 70 to 75 cent level is more likely than not. The downside risk is much greater than the upside potential. A market plan, therefore, should include price insurance and then hope that you don't need it.

Put options on December '95 futures, at, or slightly out-of-the-money may be used. The December premiums for puts have been fairly reasonable, considering about 11 months of price protection. The main disadvantage is that you pay premiums upfront. Forward price contracts alone "lock-in" the price, and you are insulated from a price decrease or increase. A contract combined with a call option is a minimum price contract, that is, if price goes higher, you can benefit. In other words, the put and minimum price contracts protect your business from a price decrease. But, should the market increase, you could benefit.



# LIGHTS

From Page 1

three miles east of Boerne off Texas 46, and about 30 miles north of San Antonio.

"We plan to keep on going until we have 1 million lights, but you can't add that many in one year," Hagee said during a tour of his one-mile display that is open to the public through Jan. 1.

"This has been so rewarding. What else could anyone do where 99.99 percent of the comments from people have been positive?"

"Christmas is such a special time, especially for families and children. Being able to share that experience with so many people has made our holiday so much better," he said.

This is the third year the presentation has been open to the public. Last year's display attracted visitors from every state in the United States and from as far away as England.

Admission \$3 per person, with children under 3 years old admitted free. The drive-through presentation is open from 6 to 10 p.m. weeknights and from 6 to 11 p.m. weekends and holidays through Jan. 1.

In addition to the dazzling lights, the attraction features musical presentations, and animated and live characters, including animals. Thirty lifelike mannequins were recently installed to replace painted figures.

"The mannequins add new life to the displays," Hagee said. "Our big problem was finding mannequins with the right facial features."

"Did you know it is impossible to find short, plump mannequins with pointed ears that we could use as elves?"

"That is something we will have to work on next year."

Hagee said interest in the display was so high in 1993, he has hired traffic control officers to direct traffic this year, and the Texas Department of Transportation has installed direc-

tional signs on Texas 46.

"We really had no idea the response would be so great," he said, pointing out that the display route handles about 13 cars every 40 seconds.

"At capacity, it takes about 30 to 45 minutes to see the display. But when people get in here, they seem to lose track of time."

"The Christmas spirit here is like magic, where time doesn't mean anything. I don't know how many people there have been who have asked to just turn around and go back through the display," he said.

While Hagee and his family members work seven days a week from August to November to design the displays, run wire, install lights, paint, and take care of the other jobs, their family labor is founded upon Hagee's extensive experience in the tourist industry.

Before Hagee purchased the 750-acre Star H Ranch in 1992, he created and operated one of Oklahoma's top tourist attractions, Arbuckle Wilderness, for 15 years.

"This lighting display was meant to be hobby, but it isn't a hobby anymore. We are really putting a lot of work into it that is our way of supporting this community that has been so supportive to us."

"There is such an upbeat, positive nature of people of South Texas," Hagee said.

Hagee's display has been a welcome attraction in Boerne, prompting some local businesses to stay open at night to take advantage of the increased traffic.

"I don't think anyone was prepared for the success he has had," said Paul Kirtley, spokesman for the Greater Boerne Chamber of Commerce.

"The 'Follow the Star' display has put Boerne on the map. We are getting calls from everywhere asking for information on the display," he said.

"Any time you have this much traffic coming to the area, it is good for everyone," he added.

Among the featured presentations scattered across the display trail are frolicking, dancing elves.

Childers Bros. Complete House Leveling. Oldest name in the business. Deal with a professional the first time. 352-9563, 800-299-9563.

1994 16x6 Gooseneck, slant nose. Extra nice trailer, \$3,250. Friskup Trailer Sales. 655-3341.

3 puppies; 2 rottweiler look-alikes. Great Christmas gifts! \$20 each. 655-9574 after 5:30pm.

2 pure bred longhorn calves. 1 bull, 1 heifer, not related. \$1000 for pair. 764-3486.

Fisher-Price 3-in-1 game table, \$100. 499-3216.

LARGE BILLBOARDS available on I-27 at Tullia and Hale Center. Also Lakeside near I-40 in Amarillo. Canyon Outdoor, 806-655-7121 or 655-1373.

WANT TO SELL a billboard! I'm interested in purchasing billboards within 50 miles of Lubbock, Plainview and Amarillo. Call Canyon Outdoor, 806-655-7121 or 655-1373 after 6pm.

For sale: Small spinet practice piano, \$350. Roll-away bed, \$40. Call 655-7988 after 5pm.

1991 Ford Aerostar, V-6, 5 speed overdrive, many extras. 655-3574.

1984 Chevy Caprice, in good condition, \$1800. 655-9396.

1981 Red Citation. Very reliable, never wrecked, nice body & paint. If interested call Andy or Brenda, 655-3108.

1970 Chevrolet Pickup, 350 auto, PS, PB, \$3,000.00. 655-4677.

'89 Ford 1 ton crewcab, excellent condition, new motor, \$11,000. 655-0495 or 678-2541 leave message.

1993 Geo Prism, teal green, low mileage, CD changer. See at Homeland parking lot. Call 655-1537.

1992 Chevy Cheyenne, extended cab, short bed, bucket seats, 5 speed, V-6, 27,000 miles. \$13,500. 655-4140.

Console stereo for sale, very nice condition, \$100. 655-3141 after 6 p.m. weekdays, or anytime weekends.

For sale: 8 year old female Pomeranian. Well trained & well behaved, \$75. 655-6185.

For sale: Registered blue Australian Shepherd Christmas puppies. 7 weeks, shots started. 488-2777.

Adorable Christmas puppies for sale, \$10. Call 655-1251 after 6pm or leave message.

AKC registered female SharPei, 1 1/2 years old. Will sell for \$100 or trade for puppy. 655-8700.

LIKE NEW sofa, blue & earthtones, silk flower arrangement to match. Singer sewing machine. 622-1231.

Gas & Electric Ranges, Washers & Dryers. Good Selection! Quality Appliance, 1911 4th Ave. 655-9219.

JUST IN TIME FOR CHRISTMAS! Portable sewing machine, Nelco cam like new Wedgewood blue rocker recliner by Lane. Citizen wide carriage printer. 655-7540.

Help keep pounds off through holidays. Have more energy too! Or, give nutrition, energy, weight loss products as Christmas gifts. My company cares about good nutrition. Glenda Duggan (806)364-0434.

Queen size waterbed, bookshelf headboard, full motion mattress, heater. 655-4960.

Lumber: #1 select, 2x10, 1x10, metal desk, IBM typewriters, visual & sound equipment. 655-2383.

Lovely townhouse in Red River for New Years or the ski season. Sleeps 8, all amenities. Rent by day/week. 655-4461 or 655-1316.

Locking ski rack, fits car/truck with rain gutter, holds 4 sets of ski's. \$75. 655-7968.

JUST IN TIME FOR CHRISTMAS! Sega with lots of games for sale. Call Kris, 655-1373.

Blue Fox fur jacket (small), only worn once. Paid \$1800 new, asking \$500. 655-1785.

Bahama Cruise! 5 days/4 nights. Underbooked! Must sell! \$279/Couple. Limited tickets. (407) 767-8100 ext 6205. Mon - Sat 9am - 10pm.

FOR SALE: Size 7 girl's jumpsuit, Men's Wrangler jeans 34x32, Misses dress size 14, Misses size 12 denim jumpsuit. Call 655-1467.

Dorm refrigerator for sale, \$50. 655-6185.

Copies of the 120 page Centennial edition are available at The Canyon News for \$2.00 each. 1500 5th Ave.

For sale: Zenith 25" console TV, cable ready. 655-4960.

Console piano, oak finish, played on very little. 655-4960.

## WIT & WISDOM OF "Dangerous Don"

### HAVE YOU BEEN TO A HOG KILLIN'?

Howdy, neighbors!

Ole Dangerous considers himself to be a gentle soul who is more than willin' to live and let live. I reckon there is somethin' to be said for the "dynamic diversity" of we mortals.

We're not all alike. Our backgrounds are different; different cultures, educations, concepts, values, etc.

One of the first differences that I personally noticed was boys and girls. Now, there's a difference for you! I happen to consider that difference to be some of God's best work. That difference often moves me to proclaim, (in my limited French) "Viva La Difference!"

I do confess to one deep-seated prejudice though.

What first brought my narrow minded attitude home to me, was a trip I was called upon to make to the East Coast a couple of years ago to confer about some proposed consultin' work.

I knew I was in trouble right off when they shuffled me down the corporate totem pole to the thirty-third vice president in charge of "Lord knows what." This ole boy had apparently spent so many years lookin' up from the bottom of the corporate heap that he was hell-bent on impressin' somebody. He wasted the entire day tellin' me all of the wonderful things he had done.

I hadn't flown a thousand miles to hear his life's story. Finally, late in the day, plumb bustin' at the seams with frustration I asked him, "Sir, have you ever been to an old-fashioned down-on-the-farm hog killin'?"

I didn't even know I was gonna ask the question but I could tell right off that he didn't have a clue what I was talkin' about.

Dangerous didn't get that consultin' contract. It was probably because of this one great prejudice in my life that I didn't



Illustrations by Chris Johnson

even realize I had until I blurted out that strange question late in the day: "Have you ever been to an old-fashioned down on the farm hog-killin'?"

I had the entire evenin' in a lonely hotel room to ponder my hang-up. I summed it all up mentally: I don't cotton much to folks who ain't never been to a hog-killin'!

That happened two years ago and I had managed to put it out of my mind as a passin' negative life-experience, best forgotten.

Until yesterday, when we had the coldest day on record in Windy Valley. It was so cold they had to start the Bionic Woman with Jumper Cables! It was so cold Superman froze his "S" off! It was real hog-killin' weather.

The bitter cold brought it all back to me. Course, you had to have cold weather so the meat wouldn't spoil before you could get it salted or sugar-cured. We didn't have refrigeration.

I may describe for you some time the details of hog-killin' day. Suffice it to say, it was cold and gruelling work from daylight to dark.

I was really sayin' to that corporate type: "Feller, you can't slice bacon by talkin'! Somebody has to butcher the hog!"

Ya'll come see us, ya hear?

Provided for your entertainment by MRL.



Just in Time For Christmas at MRL - Good Selection Of Toys For Good Little Girls and Boys

<b>Future Express Mini Train with Bump and Go</b> Action and More <b>\$11.50 Ea.</b> <b>Ninja Cycle Battery Operated Mini Cycle</b> Lots of Fun! <b>\$11.50 Ea.</b>	<b>Mini Aerocop with Bump and Go Action, 5 Special Actions</b> <b>\$3.25</b>	<b>Acrobatic Crown, 15 Actin Acrobatic Clown Show</b> For The Kids <b>\$11.50 Ea.</b> <b>Drumming Dinosaurs, Bump and Go Action</b> <b>\$8.95 Ea.</b>
<b>Space Cop 8 Sounds and Flashing Lights</b> Bump and Go Action <b>\$7.50 Ea.</b> <b>Lite Up Yo-Yo's</b> ONLY..... <b>50¢ Ea.</b> <b>Crayons Pkg. of 64</b> ONLY..... <b>40¢ Ea.</b>	<b>Just in Time For Christmas at MRL</b>  Good Selection of Toys For Good Little Boys & Girls	•Lots of Other Toys to Choose From Including Radio Control Cars.... •Dolls, & many Stocking Stuffers. Hurry While Selections Last <b>Christmas Cards</b> <b>25¢ Ea.</b> or 15 for <b>\$1.50</b>
<b>Christmas Wrapping Paper</b> 4 Rolls for <b>\$2.00</b> <b>Christmas Decorations</b> <b>25¢ and 50¢ Ea.</b>	<b>Potpourri- 3 Different Scents to Choose from</b> <b>50¢ Bag</b> <b>Batteries, Size C 2 Pack Only</b> <b>25¢ Pack</b>	<b>10" Non Stick Frying Pans</b> <b>99¢ Ea.</b> <b>Small Crystal Picture Frames</b> <b>50¢ Pack</b>

Open Mon.- Fri., 9:00A.M. - 5:30P.M. Sat., 9:00A.M. - 5:00P.M.

**Merchandise Recyclers Liquidators** Shop at all 3 Locations & Save!  
**98** Fillmore Kitchen & Bath  
**99** 373-6662 • Amarillo  
**100** Fillmore Door Store  
 374-6662 • Amarillo  
 Pierce Main Store  
 372-6662 • Amarillo

## Want to Subscribe?

It's easy and inexpensive. You get 104 issues of *The Canyon News* for just \$21.50 (\$12) for six months) if you live in Randall and surrounding counties, or \$31.50 a year elsewhere. Quite a bargain these days, so why not renew that subscription or send one to a friend or relative? Send check with subscription order.

Name.....  
 Address.....  
 State..... Zip.....

Mail coupon and check to  
**THE CANYON NEWS**  
 P.O. Box 779  
 Canyon, TX 79015







# Fishing fair for week at West Texas lakes

**ARROWHEAD:** Water clear; normal level; black bass fair; white bass good on minnows, many big fish being reported; crappie good moving toward shallows on minnows; catfish fair.  
**BAYLOR:** Fishing

poor, very few fishermen out.  
**FORT PHANTOM HILL:** Water murky; 6 feet low; 60 degrees; black bass poor; white bass fair to good; hybrid stripers fair; crappie fair to good; catfish fair.

**FRYER:** Water clear; 6 feet low; 60 degrees; black bass poor; white bass fair to good; hybrid stripers fair; crappie fair to good; catfish fair.  
**GRANBURY:** Water clear; normal level; 60 degrees; black bass fair

up to 4 pounds, hitting best on spinner baits; striped bass slow; white bass fair in 20 feet of water on silver slabs and white on cheese bait in 31 feet of water.  
**OAK CREEK:** Water 8 feet 2 inches low; 58

degrees; black bass slow to 6 pounds on plastic worms; crappie fair off of docks in 20 to 25 feet, a few jig fishermen are catching crappie in hot water area; catfish slow.  
**O.H.IVIE:** Water 59 degrees; black bass spot-

ty, some fish are being caught on crank baits in 5 to 15 feet of water along shorelines, plastic worms seem to be doing best in 20 to 30 feet of water on points located at the mouth of rivers, creeks and draws.

## EATERY

From Page 1

no idea," owner Roye Pigg says with a chuckle, ushering me through the entrance.

But people do find the Sportsman, located across from the Allsup's in downtown Quitaque. They come from all over the South Plains, and from even as far as Fort Worth and Austin, to graze on the Sportsman's famous ribs and fajitas.

Friday and Saturday nights are so packed, I hear, that it's hard to find a table. Roye says he serves between 200 and 250 people each weekend.

The night life in this town of 500, about 90 miles northeast of Lubbock, perks up after 9:30 p.m. on weekends. They push the tables aside in the Sportsman, clear the wooden floors and let the two-steppin' begin.

"It's all in fun. It's not wild — it's just fun," says Roye, 45, taking a quick sip of coffee and proudly surveying the bar. He bought the place five years ago.

Just looking at the interior of this place is

fun. A black-and-white sign above the bar bluntly proclaims, "No Sniveling." Placards from area towns and from cities as far away as Canada grace the rustic room. All of them were donated by customers, Roye says.

Other items cover the walls, too. Railroad crossing signs. A chair that a patron broke one night. Stuffed sheep heads, and the furry head of a snarling, wild hog. And my personal favorite, the hide of Old Bob.

Of course, there's a story behind Old Bob and how he came to be tacked to the wall. Warren Merrell, the town's grocer, leans in his chair and tells the tale.

Old Bob was a wild bobcat that was befriended by Cody Bell, a local rancher.

"He caught that cat going across the road at the edge of town. He kept him for 60 days and petted it every day in a cage," Warren says, taking on the solemn voice of a storyteller. "(Cody) said he (the cat) was just as wild, but the old cat stayed around there. He'd come up to the house at night. Cody

would put feed out on the porch."

"One day (Cody) decided to call ducks," Warren says. "He walked about a half a mile from his house, started calling, and he turned around and there was a cat over there under a tree. So he just zeroed down on it and shot it."

"And he never did think, until he got about half way to his house, that 'You know that ol' cat looked an awful lot like Old Bob,'" Warren adds, grinning.

Tales like this are just part of the charm of the Sportsman; the locals make up the rest. It's common to see a customer answer the phone or refill coffee cups.

"It's more like home," Roye says of the Sportsman's appeal. "It's real comfortable. You come in and do what you want."

But one thing isn't allowed: horse riding. A few years ago, an overzealous patron rode into the place on a wild horse. The beast fell, broke a table and lay flailing on the floor.

At the time, it wasn't funny, Roye insists over the snickers erupting from his customers. But he smiles eventually.

"We've got a good town here," Roye says. "In a little town, you grow so close to people. They can make you real mad. But after a while, you don't pay attention to that. It's just home."

(Distributed by The Associated Press)

## Windshields • Windshields • Windshields

### Lowest Prices Ever!!!!

#### Chevrolet & GMC Pickups & Suburbans

1978-1987 Fullsize Pickups & Suburbans (Shaded)	\$68 <sup>00</sup>
1988-1992 Fullsize Pickups & Suburbans (Shaded)	\$143 <sup>00</sup>
1993 Fullsize Pickups & Suburbans (Shaded)	\$198 <sup>00</sup>
S-10 & Jimmy Blazers (Shaded)	\$90 <sup>00</sup>

#### Ford Pickups

1980-1986 Fullsize Pickups (Shaded)	\$98 <sup>00</sup>
1980-1986 Fullsize Pickups (Tinted)	\$92 <sup>00</sup>
1987-1993 Fullsize Pickups (Shaded)	\$98 <sup>00</sup>
1987-1993 Fullsize Pickups (Tinted)	\$92 <sup>00</sup>
Ford Ranger & Bronco II (Shaded)	\$98 <sup>00</sup>

#### Dodge Pickups

1974-1993 Fullsize Pickups (Shaded)	\$125 <sup>00</sup>
1974-1993 Fullsize Pickups (Tinted)	\$100 <sup>00</sup>

\*All above prices are installed plus tax.

75% OFF All Foreign Windshields

75% OFF All Domestic Windshields

\*Plus labor, kit and tax

#### Windshield Repairs

\$20<sup>00</sup>

Installed in Lubbock Only

Offer good through December 31, 1994

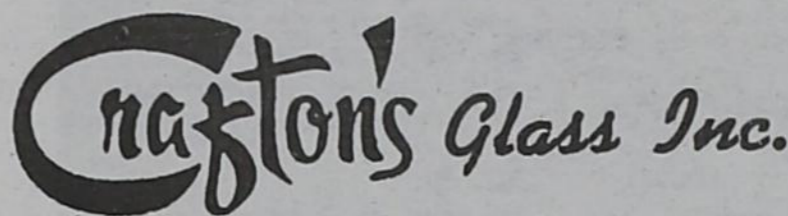

4801 I-27

744-4838

744-3511

Lubbock

**CHUCKWAGON BAR-B-QUE**

2105 Dimmitt Rd.  
Sliced BBQ Brisket  
Plate, Salad Bar,  
Hot Food Bar  
& Ice Cream Sundae

**ONLY \$5**

Mon.-Thurs. 11-8 p.m.  
Fri. & Sat. 11-9 p.m.  
Expires 12/31/94

**Holiday Gift Guide**

**STIHL®**

**WHEN YOU DEPEND ON TOOLS  
DEPEND ON STIHL**

009	14" Bar (Free Extra Chain)	\$199 <sup>95</sup>
025	16" Bar (List \$299 <sup>95</sup> )	\$279 <sup>95</sup>
026	16" Bar (List \$399 <sup>95</sup> )	\$369 <sup>95</sup>
021	16" Bar	\$249 <sup>95</sup>



**Phillips Bicycles & Mowers**

613 W. 24th  293-7892

**Delivering Technology To Your Field**

**YIELD RESULTS:**

<p>Cooperator: Larry Pirkle Location: Dumas, TX</p> <table border="1"> <tr><th>Hybrid</th><th>Moisture</th><th>Yield</th><th>Rank</th></tr> <tr><td>ICI N8276</td><td>23.4</td><td>185.3</td><td>1</td></tr> <tr><td>ICI 8285</td><td>23.7</td><td>181.8</td><td>2</td></tr> <tr><td>ICI 8315</td><td>23.5</td><td>180.1</td><td>3</td></tr> <tr><td>ICI N8330</td><td>21.3</td><td>178.4</td><td>4</td></tr> <tr><td>ICI 8326</td><td>19.9</td><td>176.6</td><td>5</td></tr> <tr><td>ICI 8344</td><td>20.7</td><td>176.6</td><td>6</td></tr> <tr><td>ICI 8272</td><td>22.3</td><td>176.4</td><td>7</td></tr> <tr><td>Cargill 7997</td><td>22.9</td><td>172.2</td><td>9</td></tr> <tr><td>Pioneer 3162</td><td>22.8</td><td>171.3</td><td>10</td></tr> <tr><td>Plot Averages</td><td>22.5</td><td>174.8</td><td></td></tr> </table>	Hybrid	Moisture	Yield	Rank	ICI N8276	23.4	185.3	1	ICI 8285	23.7	181.8	2	ICI 8315	23.5	180.1	3	ICI N8330	21.3	178.4	4	ICI 8326	19.9	176.6	5	ICI 8344	20.7	176.6	6	ICI 8272	22.3	176.4	7	Cargill 7997	22.9	172.2	9	Pioneer 3162	22.8	171.3	10	Plot Averages	22.5	174.8		<p>Cooperator: Johnny Webb Location: Plainview, TX</p> <table border="1"> <tr><th>Hybrid</th><th>Moisture</th><th>Yield</th><th>Rank</th></tr> <tr><td>ICI N8396</td><td>22.9</td><td>185.1</td><td>1</td></tr> <tr><td>ICI 8285</td><td>27.7</td><td>183.8</td><td>2</td></tr> <tr><td>ICI 8281</td><td>26.8</td><td>173.3</td><td>4</td></tr> <tr><td>ICI 8326</td><td>22.0</td><td>167.1</td><td>6</td></tr> <tr><td>Asgrow RX 899</td><td>29.6</td><td>165.6</td><td>7</td></tr> <tr><td>ICI 8272</td><td>26.0</td><td>162.4</td><td>10</td></tr> <tr><td>Cargill 7997</td><td>24.8</td><td>155.6</td><td>11</td></tr> <tr><td>Pioneer 3162</td><td>26.2</td><td>144.6</td><td>12</td></tr> <tr><td>Plot Averages</td><td>18.2</td><td>184.2</td><td></td></tr> </table>	Hybrid	Moisture	Yield	Rank	ICI N8396	22.9	185.1	1	ICI 8285	27.7	183.8	2	ICI 8281	26.8	173.3	4	ICI 8326	22.0	167.1	6	Asgrow RX 899	29.6	165.6	7	ICI 8272	26.0	162.4	10	Cargill 7997	24.8	155.6	11	Pioneer 3162	26.2	144.6	12	Plot Averages	18.2	184.2		<p>Cooperator: Jess Willard Location: Conlen, TX</p> <table border="1"> <tr><th>Hybrid</th><th>Moisture</th><th>Yield</th><th>Rank</th></tr> <tr><td>ICI 8285</td><td>20.3</td><td>204.9</td><td>1</td></tr> <tr><td>ICI 8281</td><td>20.1</td><td>204.1</td><td>3</td></tr> <tr><td>NC+ 5037</td><td>18.5</td><td>204.0</td><td>4</td></tr> <tr><td>ICI 8326</td><td>20.4</td><td>196.8</td><td>7</td></tr> <tr><td>ICI 8272</td><td>21.3</td><td>196.6</td><td>8</td></tr> <tr><td>NC+ 7304</td><td>21.7</td><td>194.4</td><td>11</td></tr> <tr><td>Pioneer 3162</td><td>22.3</td><td>190.9</td><td>13</td></tr> <tr><td>AgriPro AP674</td><td>21.3</td><td>186.8</td><td>15</td></tr> <tr><td>Plot Averages</td><td>20.5</td><td>195.5</td><td></td></tr> </table>	Hybrid	Moisture	Yield	Rank	ICI 8285	20.3	204.9	1	ICI 8281	20.1	204.1	3	NC+ 5037	18.5	204.0	4	ICI 8326	20.4	196.8	7	ICI 8272	21.3	196.6	8	NC+ 7304	21.7	194.4	11	Pioneer 3162	22.3	190.9	13	AgriPro AP674	21.3	186.8	15	Plot Averages	20.5	195.5	
Hybrid	Moisture	Yield	Rank																																																																																																																											
ICI N8276	23.4	185.3	1																																																																																																																											
ICI 8285	23.7	181.8	2																																																																																																																											
ICI 8315	23.5	180.1	3																																																																																																																											
ICI N8330	21.3	178.4	4																																																																																																																											
ICI 8326	19.9	176.6	5																																																																																																																											
ICI 8344	20.7	176.6	6																																																																																																																											
ICI 8272	22.3	176.4	7																																																																																																																											
Cargill 7997	22.9	172.2	9																																																																																																																											
Pioneer 3162	22.8	171.3	10																																																																																																																											
Plot Averages	22.5	174.8																																																																																																																												
Hybrid	Moisture	Yield	Rank																																																																																																																											
ICI N8396	22.9	185.1	1																																																																																																																											
ICI 8285	27.7	183.8	2																																																																																																																											
ICI 8281	26.8	173.3	4																																																																																																																											
ICI 8326	22.0	167.1	6																																																																																																																											
Asgrow RX 899	29.6	165.6	7																																																																																																																											
ICI 8272	26.0	162.4	10																																																																																																																											
Cargill 7997	24.8	155.6	11																																																																																																																											
Pioneer 3162	26.2	144.6	12																																																																																																																											
Plot Averages	18.2	184.2																																																																																																																												
Hybrid	Moisture	Yield	Rank																																																																																																																											
ICI 8285	20.3	204.9	1																																																																																																																											
ICI 8281	20.1	204.1	3																																																																																																																											
NC+ 5037	18.5	204.0	4																																																																																																																											
ICI 8326	20.4	196.8	7																																																																																																																											
ICI 8272	21.3	196.6	8																																																																																																																											
NC+ 7304	21.7	194.4	11																																																																																																																											
Pioneer 3162	22.3	190.9	13																																																																																																																											
AgriPro AP674	21.3	186.8	15																																																																																																																											
Plot Averages	20.5	195.5																																																																																																																												
<p>Cooperator: Rickey Rector Location: Friona, TX</p> <table border="1"> <tr><th>Hybrid</th><th>Moisture</th><th>Yield</th><th>Rank</th></tr> <tr><td>ICI 8285</td><td>19.5</td><td>213.8</td><td>1</td></tr> <tr><td>ICI 8281</td><td>17.2</td><td>198.8</td><td>2</td></tr> <tr><td>ICI N9330</td><td>17.7</td><td>195.5</td><td>3</td></tr> <tr><td>ICI 8260</td><td>17.8</td><td>189.5</td><td>4</td></tr> <tr><td>ICI 8272</td><td>18.4</td><td>188.5</td><td>5</td></tr> <tr><td>Pioneer 3162</td><td>18.7</td><td>183.6</td><td>7</td></tr> <tr><td>ICI 8543</td><td>14.9</td><td>180.0</td><td>8</td></tr> <tr><td>Jacques 8360W</td><td>21.4</td><td>162.9</td><td>12</td></tr> <tr><td>Plot Averages</td><td>18.2</td><td>184.2</td><td></td></tr> </table>	Hybrid	Moisture	Yield	Rank	ICI 8285	19.5	213.8	1	ICI 8281	17.2	198.8	2	ICI N9330	17.7	195.5	3	ICI 8260	17.8	189.5	4	ICI 8272	18.4	188.5	5	Pioneer 3162	18.7	183.6	7	ICI 8543	14.9	180.0	8	Jacques 8360W	21.4	162.9	12	Plot Averages	18.2	184.2		<p>Cooperator: Ricky Thompson Location: Gruver, TX</p> <table border="1"> <tr><th>Hybrid</th><th>Moisture</th><th>Yield</th><th>Rank</th></tr> <tr><td>ICI 8285</td><td>14.1</td><td>140.4</td><td>1</td></tr> <tr><td>ICI 8281</td><td>13.3</td><td>137.1</td><td>2</td></tr> <tr><td>ICI 8272</td><td>13.4</td><td>120.2</td><td>5</td></tr> <tr><td>ICI 8344</td><td>12.5</td><td>115.2</td><td>7</td></tr> <tr><td>Asgrow RX899</td><td>14.7</td><td>114.6</td><td>8</td></tr> <tr><td>ICI 8326</td><td>12.7</td><td>97.5</td><td>12</td></tr> <tr><td>Pioneer 3162</td><td>15.1</td><td>92.6</td><td>13</td></tr> <tr><td>Cargill 7997</td><td>14.0</td><td>92.5</td><td>14</td></tr> <tr><td>Plot Averages</td><td>13.5</td><td>112.5</td><td></td></tr> </table> <p>EXTREME STRESS PLOT - Limited Water</p>	Hybrid	Moisture	Yield	Rank	ICI 8285	14.1	140.4	1	ICI 8281	13.3	137.1	2	ICI 8272	13.4	120.2	5	ICI 8344	12.5	115.2	7	Asgrow RX899	14.7	114.6	8	ICI 8326	12.7	97.5	12	Pioneer 3162	15.1	92.6	13	Cargill 7997	14.0	92.5	14	Plot Averages	13.5	112.5		<p>Cooperator: Joe Reinart Location: Conlen, TX</p> <table border="1"> <tr><th>Hybrid</th><th>Moisture</th><th>Yield</th><th>Rank</th></tr> <tr><td>ICI 8326</td><td>17.1</td><td>162.2</td><td>1</td></tr> <tr><td>ICI 8285</td><td>18.2</td><td>155.8</td><td>3</td></tr> <tr><td>Asgrow RX899</td><td>17.1</td><td>154.1</td><td>4</td></tr> <tr><td>Pioneer 3162</td><td>17.8</td><td>152.3</td><td>6</td></tr> <tr><td>Pioneer 3225</td><td>18.5</td><td>146.3</td><td>7</td></tr> <tr><td>Plot Averages</td><td>17.4</td><td>147.2</td><td></td></tr> </table>	Hybrid	Moisture	Yield	Rank	ICI 8326	17.1	162.2	1	ICI 8285	18.2	155.8	3	Asgrow RX899	17.1	154.1	4	Pioneer 3162	17.8	152.3	6	Pioneer 3225	18.5	146.3	7	Plot Averages	17.4	147.2																	
Hybrid	Moisture	Yield	Rank																																																																																																																											
ICI 8285	19.5	213.8	1																																																																																																																											
ICI 8281	17.2	198.8	2																																																																																																																											
ICI N9330	17.7	195.5	3																																																																																																																											
ICI 8260	17.8	189.5	4																																																																																																																											
ICI 8272	18.4	188.5	5																																																																																																																											
Pioneer 3162	18.7	183.6	7																																																																																																																											
ICI 8543	14.9	180.0	8																																																																																																																											
Jacques 8360W	21.4	162.9	12																																																																																																																											
Plot Averages	18.2	184.2																																																																																																																												
Hybrid	Moisture	Yield	Rank																																																																																																																											
ICI 8285	14.1	140.4	1																																																																																																																											
ICI 8281	13.3	137.1	2																																																																																																																											
ICI 8272	13.4	120.2	5																																																																																																																											
ICI 8344	12.5	115.2	7																																																																																																																											
Asgrow RX899	14.7	114.6	8																																																																																																																											
ICI 8326	12.7	97.5	12																																																																																																																											
Pioneer 3162	15.1	92.6	13																																																																																																																											
Cargill 7997	14.0	92.5	14																																																																																																																											
Plot Averages	13.5	112.5																																																																																																																												
Hybrid	Moisture	Yield	Rank																																																																																																																											
ICI 8326	17.1	162.2	1																																																																																																																											
ICI 8285	18.2	155.8	3																																																																																																																											
Asgrow RX899	17.1	154.1	4																																																																																																																											
Pioneer 3162	17.8	152.3	6																																																																																																																											
Pioneer 3225	18.5	146.3	7																																																																																																																											
Plot Averages	17.4	147.2																																																																																																																												



"To learn more about these hybrids contact your local ICI Seeds representative or call Johnny Webb at (806) 864-3557 or Darren Young at (806) 296-6009.





**This man  
applied  
at seven  
small  
businesses  
that have a  
drug policy.**

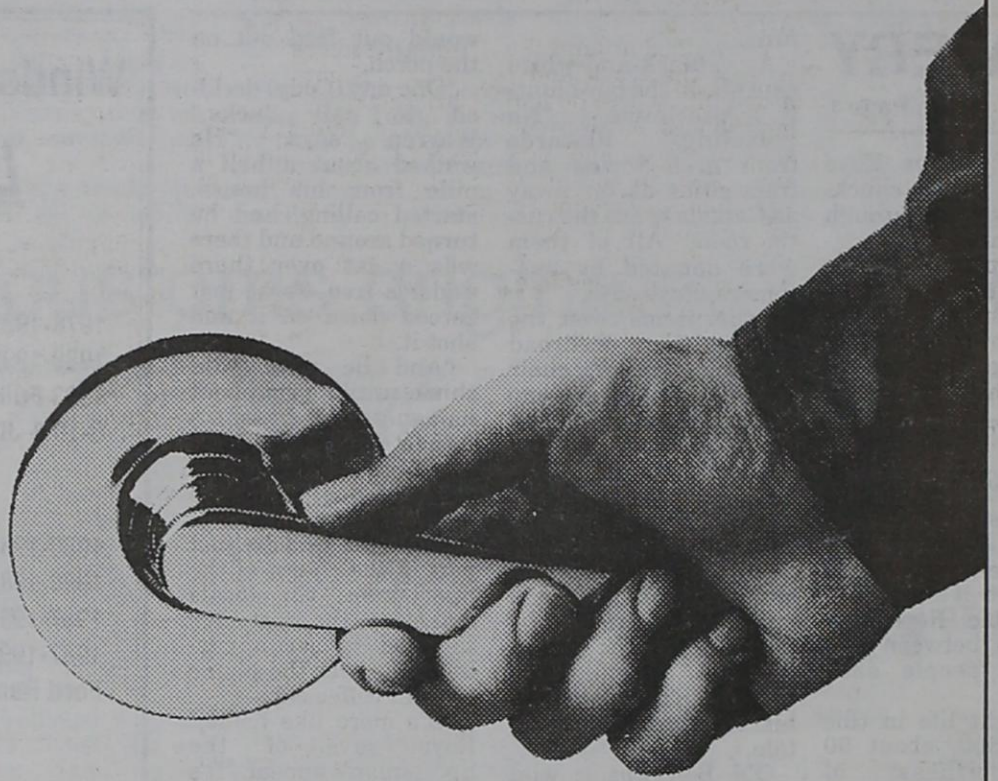

## **Now he's at your door.**

If your company doesn't have a drug policy, you're just what he's looking for. Because he has a drug problem - a problem you can't afford.

It's a problem that can mean low productivity, more health claims, on-the-job accidents, even costly lawsuits. That's why many small businesses are implementing a drug-free workplace policy.

Protecting your business from drugs is easier than you might think. Just call 1-800-843-4971 for a free guide on how to establish a drug-free workplace. The guide is simple to understand and the policies can be modified to the needs of your business.

If drug users know your business doesn't have an effective drug policy, you might as well be inviting them in.

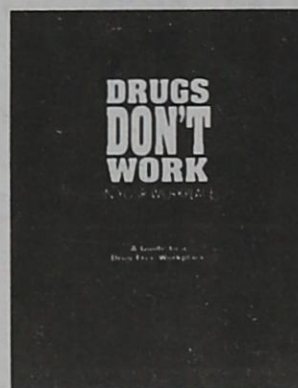

**1-800-843-4971**



**Texas Prevention Partnership**  
BRINGING TEXAS A NEW VIEW OF HUMAN POTENTIAL.



Christmas Eve 50 years ago in Italy

# Bomber pilot recalls WWII Christmas

**(EDITOR'S NOTE — As a B-17 bomber pilot and squadron leader in World War II, Capt. James McGarry flew 29 missions over Germany and other targets in Europe, based much of the time in Foggia, Italy. As a columnist for the Schenectady (N.Y.) Gazette shortly after the war, he wrote the following remembrance of a Christmas Eve in Foggia 50 years ago.)**

By JAMES MCGARRY

For The Associated Press  
FOGGIA, Italy (AP) — It was Christmas Eve 1944 in Foggia, 4,000 miles, 19 bombing missions, and an eternity away from home.

I stood in the late afternoon watching the Italian skies darken. A squadron of bombers, lumbering along beneath a deep, gray bank of clouds, floated over the "spur of the boot" of Italy, droning like bees.

A P-51 flashed above the treetops, leaving the whining, whirring noise of its propeller dying in its wake. The playful pursuit ship faded rapidly into the somber darkening evening and I turned from watching it to walk toward the club.

It began to snow. As I came to the edge of the olive grove that was the camp of the 419th Bomb Squadron, a truck, laden with roughly cut logs, turned off the Foggia-Lucera Road.

It came to a stop alongside me and Lt. Jack deKruif of Grand Rapids, Mich., stepped down from the cab. A spark of pleasure in his eyes leapt when he saw me admiring the cargo and spread to laughter on his tired face.

"Look what Santa Claus brought," he said. He was red from the cold and his hands were

raw. There was a smear of dirt across his nose. His sleeve was torn. Hanging loosely around his hips, cowboy fashion, dangled a belt and holster which carried an Army .45.

We walked around the rear of the truck and I asked him where he had got the logs, for firewood was a scarce and precious item in the areas surrounding Foggia. He told me that he had gone into the hills near Ariano with Pasquale, an Italian POW who was his helper. They had bought the load from a farmer.

"It will be a red-hot Christmas in our fireplace tonight," Jack said.

About 8:30 that evening the most unusual Christmas party I had ever attended began.

A voice called over the loudspeaker, announcing that the bars were open in both the enlisted mens' and the officers' clubs.

Hundreds of fliers and ground-support personnel, dressed smartly in class-A uniforms, their brass polished, shoes glistening and trousers pressed, came gradually out of their tent and walked up the paths between the olive trees.

There was an inch of snow on the frozen ground and winter flavored the air with snappy gusts of wind that whipped swirling flurries from the branches of the trees.

Someone had hooked the loudspeaker connection to the radio and from the Army station in Foggia came gently, homey Christmas music ... "Silent Night" ... "White Christmas" ... "Adeste Fideles" ... "I'll Be Home for Christmas"...

I went into the club with Lt. Tom Lubeski of St. Louis, Mo., one of my new tentmates. We kicked the snow from our best shoes and hung our coats on nails near the door. There were more than 70 pilots, navigators, and bombardiers dressed as though for a general's inspection, throughout the club.

At the farther end of the building stood a Christmas tree which Jack had brought from the hills. Someone had decorated it with real candles that had come in a package from home.

My co-pilot, Chuck Whiting of Norwell, Mass., was behind the bar. He had on a red bow tie and a homemade apron. Sgt. Bill Rogers of Brandon, Miss., who would be shot down a few weeks later, was stirring something in a gigantic bowl at one end of the bar.

A group of fellows clustered about the fireplace, with glasses of Italian rum and grapefruit juice in their hands, singing Christmas carols while Lt. Don Higgins of

Sacramento, Calif., lovingly worked the keys of an ancient piano. The fire was crackling.

Tom and I stood at the end of the bar with four or five friends and talked about home, about combat, about the wonderful party we were having.

Everyone was in a holiday spirit.

At the height of the party, shortly before midnight, a homemade stove that had been installed in a corner of the building set fire to the papered ceiling and the flames spread rapidly through the club, putting an end to the celebration.

We fought the fire with buckets of water at first, but the roof, built of wood and decorated with highly inflammable materials, caught up quickly.

We stood outside in the snow and watched

emergency fire crews extinguish the flames. When the fire was out, Tom and I went back into the charred building to view the damage.

The crude chairs and tables had been broken and partly burned. The Christmas tree was a black skeleton and water, pieces of burned paper and wood covered the floor.

Jack deKruif came running inside. "Come on you guys," he hollered, "get to work."

He looked at the fireplace. It was dripping water and the ashes were wet. Jack took a stick, scraped the fireplace and went outside. He came back in a moment, carrying an armload of wood.

Pasquale brought in a huge log and placed it in front of the fireplace while Jack lit another fire.

Someone had put new

candles on the mantle. Chuck said, "Hey you guys, I salvaged a case of beer ... of course, it's a bit warm, but it's beer."

We sat down on the log in front of the fire. Pasquale opened the case and passed out the drinks. Chuck told him to sit down and have a beer with us.

Pasquale raised his bottle, smiled and said, "Buono Natale."

"Yes," Chuck said, "And a Merry Christmas to you, Pasquale."

But the stench from the burned building soon got to us and we had to leave.

White Space  
Does  
Increase  
Readership  
Of Ads! ! !

**Antiques & More  
Potpourri**

Curio Cabinets-Wardrobes-Oak Desks  
Wardrobes-Tables-Chairs-Kitchen Cabinets  
Stained Glass- Beautiful Glassware

\*\*Good Selection of Gift Items\*\*  
\*\*\*All Christmas Items Marked Down\*\*\*

122 N. Maxwell Tulia, Texas

★ VALUABLE COUPON ★

**TEXAS COUNTRY HAMS**

Sliced, simple to serve

Slowly smoked ready to eat

Less fat, Less salt

Honey & Spices

**\$2.50 OFF**

Holiday Shop now open

Gourmet food - Gift Baskets

Expires 12-31-94

Reserve Your Ham Now!!

3305 Bell • 353-Hams (4267)

1-800-699-4267

South Plains Mall  
Lubbock, Texas  
785-4267

★ VALUABLE COUPON ★

**IMPROVEMENT  
LOAN  
PROGRAM**

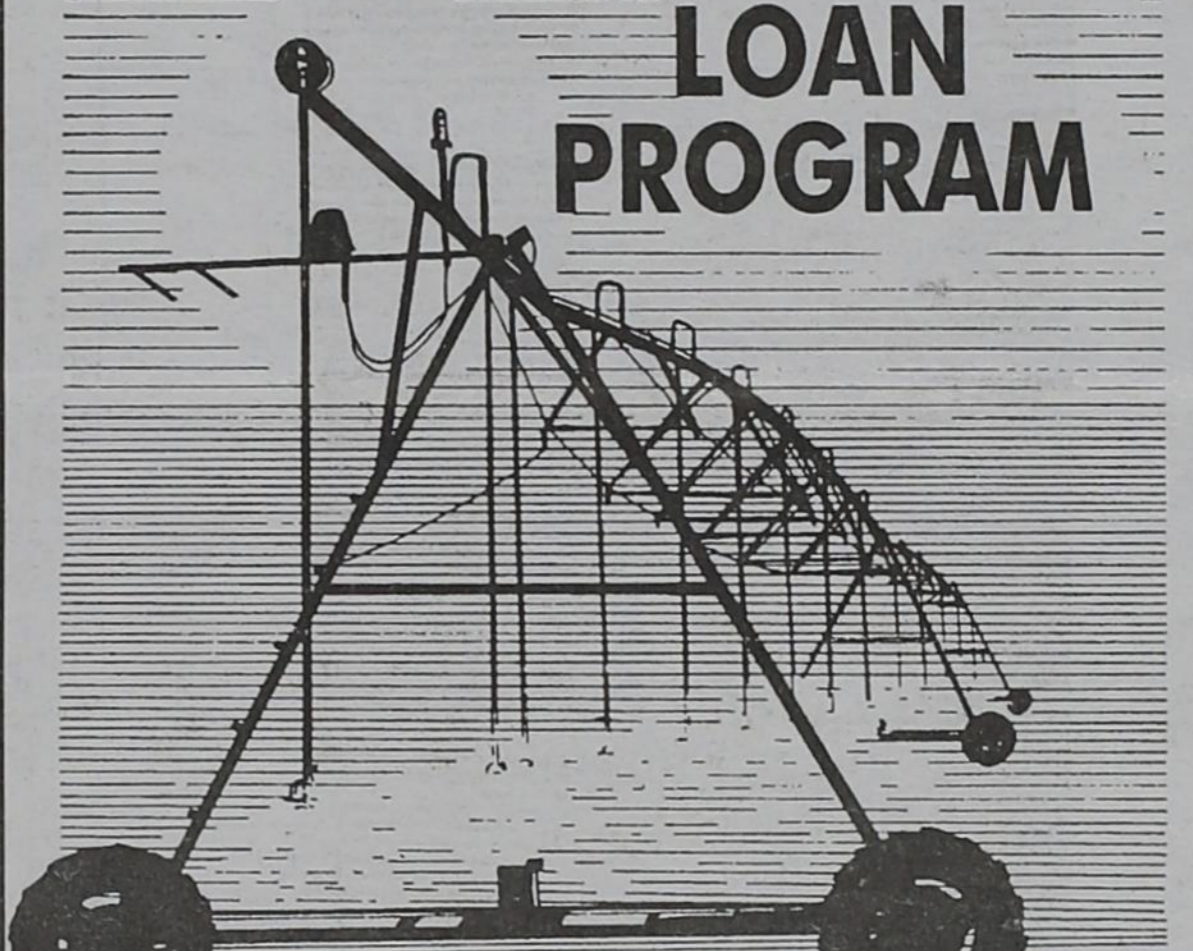

**Federal  
LAND BANK  
Association**

Loans are available to purchase center pivot sprinkler irrigation systems, to drill irrigation wells and to install underground tile.

Several Interest Rate Plans Available

- VARIABLE RATE
- ADJUSTABLE RATE
- FIXED RATES FOR 5, 7 OR 10 YEARS

Long-term real estate loans are also available for land purchases, refinance, rural residential purchase, construction and improvement.

**Stop by or give us a call!**

<b>AMARILLO</b> 3615 S. Georgia (806) 353-6688	<b>LEVELLAND</b> 613 Ave. G (806) 894-6155	<b>LUBBOCK</b> 1117 65th Drive (806) 745-3277
<b>CHILDRESS</b> Highway 83 south (817) 937-61812	<b>LITTLEFIELD</b> 504 Phelps Ave. (806) 385-4425	<b>MULESHOE</b> 316 Main Street (806) 272-3010
<b>CROSBYTON</b> 207 S. Berkshire (806) 675-2761	<b>DIMMITT</b> 105 W. Bedford (806) 647-4178	<b>PLAINVIEW</b> 629 Baltimore (806) 296-5579
<b>HEREFORD</b> 709 N. Main (806) 364-1464	<b>SPUR</b> 403 east Hill St. (806) 271-3378	<b>TULIA</b> 115 N. Armstrong (806) 995-3129



# Advertise In The West Texas Country Trader!

□ The *COUNTRY TRADER* is a weekly section produced and published by these following newspapers:

- *Abernathy Review*, Hale County 298-2033
- *Canyon News*, Randall County 655-7121
- *Castro Co. News*, Castro County 647-3123
- *Clarendon News*, Donley County 874-2259
- *Lorenzo Examiner*, Crosby County 634-5390
- *Plainview Daily Herald*, Hale County 296-1300
- *Rails Reporter News*, Crosby County 634-5390
- *Slaton Slatonite*, Lubbock County 828-6201
- *Tulia Herald*, Swisher County 995-3535

It reaches across the 10,000 square miles of the Texas plains and lower Panhandle illustrated here:

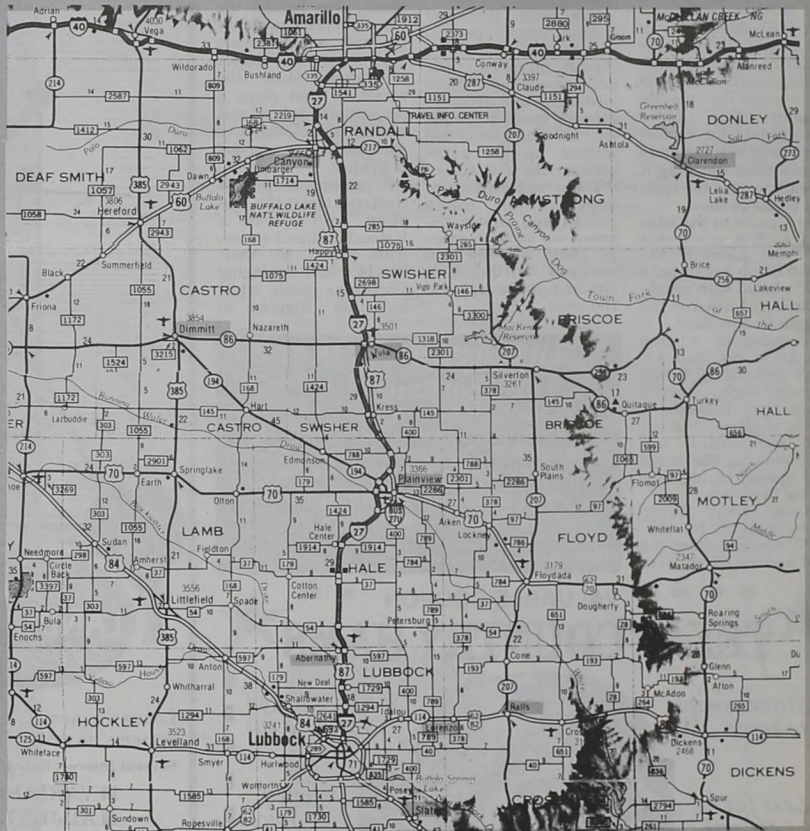

Reach a  
**\$3.3 Billion**  
dollar market  
with the  
West Texas  
Country Trader

For approximately  
double the ad cost  
of one newspaper,  
you can reach  
  
**Ten**  
newspapers!  
over 31,000  
Paid Subscribers

Reach this rich  
market with a  
quarter page ad  
for as little as  
**\$5.40**  
per thousand  
homes.

Advertisers wishing  
to expand their  
businesses by  
reaching interested  
buyers all across  
this area should  
call the publication  
in your area.