

Farwell to open stock show season

The 44th annual Farwell Junior Livestock Show will be held at the Farwell Community Center starting at 11 a.m. on Saturday, Jan. 9.

The doors open from 9 to 10:30 a.m. for youths to bring their animals, with the weight on all animals turned in during that time.

Farwell staffers, 4-H and FFA students and their parents will set up the pens and make arrangements for the show on Friday, Jan. 8.

The judge will be Jeff Malloy, Cochran County ag extension agent.

Farwell ag teacher Tomee England expects a good number of goats, pigs, lambs, steers and beef heifers to be entered again this year.

Ribbons will be awarded, plus belt buckles will be given the champions and showmanship winners.

The ring chairman will be Leslie Curtis. Fred Chandler will again handle the master of ceremony duties.

The Farwell 4-H will preside over the concession stand and it will feature a lunch menus.

Friena – There will be no show again this year.

The Lazbuddie Junior Livestock Show will be held Jan. 23 at 1 p.m. in the high school ag shop.

Judge will be Alan Patranella.

Grand champions and showmanship winners will receive belt buckles, and reserve champions will be honored, too.

This will be the second year in a row it will be held at the school. Previously, it was held in Friena.

The Parmer County stock show will be held Jan. 13, 14 and 16.

Judges will be: lambs and goats, Jay Waller; steers, Dennis Poole; and barrows, Larry Moore.

Here is the event schedule:

Jan. 13 – 1 to 5 p.m., weigh in of all animals; barrows will be classified as weighed; 5 p.m., classify lambs; and 5:30 p.m., classify steers.

Jan. 14 – 8 a.m., goat show begins followed by the lamb show; 11 a.m., steer show; gilt show, and 1 p.m., barrow show.

Jan. 16 – 1 p.m., premium sale.

The 2009 grand champions were Logan Mason, goats, barrows and lambs; Zac Stancell, heifers, and Drew Johnson, steers.

The Parmer County Stock Show advisory committee consists of: Farwell, Darren Haseloff and Kyle Stancell; Bovina, Brett Whitten and Charles Wilkins; Lazbuddie, Ed Terry and Rick Seaton; and Friena, Cody Kimbrough and Robert Osborn.

Stock show board members are:

Farwell – Tomee England, Carey Stancell, Keith Hadley and Charles Christian.

Bovina – Luke Steelman, Buddy Prather and Tony Beauchamp.

Lazbuddie – Terry Jesko, Sid Morris, Shane Mason and Chris Timms.

Friena – Ricky Barnett, Mark Osborn, Paul Smith and Monty Schueler.

County 4-H – Scott Johnson, Benji Henderson, Sean Mason, Al Kerby Jr. and

Continued on Page 2

FARWELL · BOVINA · LAZBUDDIE · TEXICO

THE STATE LINE TRIBUNE

"Official Publication of Parmer County"

JANUARY 7, 2010 NUMBER 23 98th YEAR 50 CENTS

Races set for county judge; Farwell and Friena JPs; and Lazbuddie county commissioner

The filing period ended on Monday for the Texas local elections and Parmer County will have a pair of three-way races – with runoff elections a good probability.

Parmer County Democrat Chairman Robert White said no one signed up to be in the Democrat primary except for 287th District Court Judge Gordon Green.

This is the first time in Parmer County's history that no county candidates signed up for a Democrat primary.

Green is seeking re-election and has no opponent in the fall. Thus, he will be re-elected.

It's a different story on the Republican side with four races, reports County GOP Chairman Floyd Rev.

The big race will be for Parmer County Judge.

This post opened with the retirement of Bonnie Heald at the end of this year.

Seeking the GOP nomination for county judge are Michelle Agee, of Farwell; Chris Alexander, of Friena, and Trey Ellis, of Friena.

Ellis filed last week and was a surprise since he had earlier said he would seek re-election as Friena area Justice of the Peace.

The other three-way race will be for Farwell area Justice of the Peace. Seeking the post are incumbent Pam Haseloff, Randy Mitchell and Linda Moss Hardy.

If a candidate does not get at least 50 percent of the votes, a runoff is called for.

There are two other races on the GOP ticket:

1. Lazbuddie area County Commissioner:

Lloyd Bradshaw and Jimmy Weaver.

2. Friena area Justice of the Peace: Jerry Loflin and Jo Beth Gipson.

The Lazbuddie area post became open when Elvis Powell announced his retirement. And the Friena JP post is open since Ellis is seeking the county judge's post.

The other posts on the ballot are held by incumbents who also have no opposition in the fall, and thus will be re-elected:

County Clerk – Colleen Stover.

County Treasurer – Altha Herington.

District Clerk – Sandra Warren.

Bovina area Justice of the Peace – Sandra Clayton.

Bovina area County Commissioner – James Clayton.

The primary elections will be held on March 2.

Get out and support your teams!

Photos by Jill Timms, Cary McFarden, Deanna Curtis and J.R. Ivins.

Lazbuddie



Bovina



Texico



Farwell

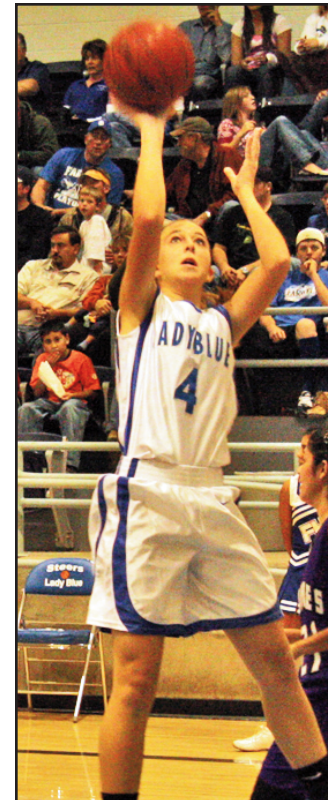



Heather Reed, Missionary

(Editor's note: Heather is the daughter of Kathey and Robert Adams, of Progress. She began in August a year-long mission trip to 11 nations and will send periodic updates to the Tribune.)

My next stop is Arad, Israel:

Some of my favorite time in December was spent in the soup kitchen. We built relationships with the other volunteers as well as with the people who came to get food.

It was great to see how this particular soup kitchen runs. It asks hotels near the Dead Sea to send their extra food, that they would be throwing away anyway, up to town so that they can use it to feed the needy here. It is great to see a need being met in such a tangible and easy way.

They also work solely with volunteers. They especially try to get the people that come for food to work with them. Several of the people that we worked alongside had originally come to the soup kitchen only for food and now are serving those around them. That was really cool to see.

The place where we were staying has a laundromat they are trying to get up and running for the community and to bring in a steady income to the ministry.

It is so exciting to see a ministry work to be

self-sustaining and, more importantly, locally-sustained. We opened it for our squad mates to do laundry while in town so that we could get laundry done while supporting the ministry. They will also use the laundromat mat as a base for a clothing distribution center. This was great because with us going into Africa for the summer, then on to Asia, we won't need our warm clothes any longer. So we left lot of warm winter clothes with them to give to others.

Our team had the opportunity of living at the retreat center all month. It's kind of our center of operations as a squad, so people were here most days. Whenever a person needed a day off, they would come over to the center and spend the day. They could sit on our patio with the amazing view, go on a walk in the desert or just sleep all day.

We had the opportunity as a team to love on these people and to build them up as brothers and sisters. Mostly, our trick was coffee and tea and card games, but we did quite a bit of conversation and prayer as well. It was great to see people come in absolutely exhausted and having poured out all of themselves and to see them leave the next day refreshed and ready to pour out some more.

One of my favorite things about being in Israel was getting to celebrate Shabbat. It comes every week without fail. We prepare for it all day, by cleaning the house and getting dressed up ourselves and doing any shopping that may be necessary for the next day.

This was necessary because the entire country shuts down from sundown on Friday until sundown on Saturday. It was

really kind of refreshing to be a part of this. The ceremony starts at about 4:30 on Friday afternoon: we worship, say the blessings, sing some songs and then eat a big dinner.

Another thing I liked about Israel was seeing how many different types of people were represented here. Walking around town, you would see Arabs, Africans, Russians, other Europeans, even Peruvians. It was awesome. How many places in the world can you see such diversity in one place?

One day, we got to float in the Dead Sea. That was pretty cool. You really do float. And we spent a day touring Masada. We hiked all the way up to this city that is set on top of a rock. This is the place that a group

of Jews killed themselves in the 1st century in order to keep from being subject to the Romans.

We also visited En Gdi, an oasis where King David wrote some of the Psalms in the Bible; Hezekiah's Tunnel, a water shaft that was built so that the city could still access water even during a siege; the Western Wall (also known as the Wailing Wall) the only part of King Solomon's temple that is still standing.

Other visits were to Nazareth, seeing the Church of the Annunciation, the site where they believed Mary found out she would give birth to our Lord; Capernaum, the city that Jesus made his home for awhile; the Sea of Galilee, and the Jordan River.

Courthouse Notes

The Parmer County clerk's office last week recorded these warranty deeds:

Calvin Goodin – Helton Oil, Garden lots 15 & 16 S31 T9S R1E.

Helton Oil – Calvin Goodin, same as above. Helton Oil – Frank Galvan, same as above.

Metropolitan Radio Group – Ministerious Unidos Para Christo, Garden L 17 tr Garden L 18-19 S31 T9S R1E.

Don Fortenberry – Elizabeth Fortenberry, N 1/2 NE 1/4 S13 Blk B Rhea Bros.

Almeda Goolsby et al – Carolyn Widner, S 320 ac S29 Blk C.

HUD – Francisco Estrada, L22 B6 Lakeview Add, Friona.

Ronnie Stevick – Rafael Rocha, L23-25 B13 Drake Add, Friona.

Ready to play?

Land, sea or open road. No matter where you play or how you define recreation, one thing is certain: protecting the boats and RVs that make life more fun is a top priority. That's where we come in. Where ever you go and however you get there, we'll make sure your pastimes have a future. See the friendly staff at General Insurance for all your motorcycle, boating or RV needs!

General Insurance Agency

500 Mitchell St. Clovis, NM 88101

www.gia-clovis.com

Meet Farwell's Class of 2022

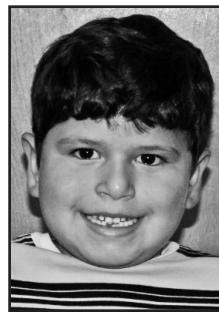

Jacob Gutierrez is a Farwell kindergarten. His birthday is Nov. 23.

Parents are Christy & Victor Gutierrez. His sister is Victoria. Grandparents are Elvira Muniz and Judy Pena.

He likes to play with Thomas the Train, sing, dance, watch TV and play with his sister.

Favorite color is blue. Favorite foods are mac & cheese, and pancakes.

He doesn't like carrots.

Sponsored by the Farwell Banking Center of Muleshoe State Bank

Stock shows

From page 1

Wade Schueler.

Officers are:

Mack Heald, general superintendent; JeDon Gallman, general assistant superintendent; Lesley Curtis, swine superintendent; Kevin Schueler, lamb and goat superintendent; Jerry Simmons, cattle superintendent.

Also, JeDon Gallman, president; Wade Schueler, vice president; Gary Patterson, secretary, and John Jarecki and Dale Schueler, treasurers.

General regulations include:

The show is open to all 4-H, FFA and FHA boys and girls under the supervision of the county agent or vocational ag teachers of the county. Entrants must be enrolled in grades 3 through 12 in one of the four public schools in the county or be a county resident attending a home/private school in those grades.

Floor prices will not be set on any animals. All animals will be taken home by exhibitors after the show.

Pens will be assigned by community.

Exhibitors may show four animals per species – and seven in total.

Each exhibitor may only sell two animals in the premium auction.

The state mandated “no pass, no play” rules will apply. If an exhibitor is not scholastically eligible by UIL rules, then the exhibitor and his/her animals are not eligible to compete in the county show.

Showmanship rules are:

Steer, barrow, lamb and goat shows will have two age divisions, junior 8-13 and senior 14 and up. Each species judge will select showmanship winners within their division.

Showmanship classes will be held upon the completion of judging each species and will be open to all exhibitors of that species, within each age division. Showmanship selection will be based on the exhibitor's efforts within the classes as well as during showmanship competition class.

All ages will be as of Jan. 1, 2010.

The State Line Tribune, LLP, (USPS 520220) is published weekly for \$24.00 in Parmer, Curry and Bailey counties, and for \$35 elsewhere by State Line Tribune, LLP, P.O. Box 255, Farwell, TX 79325-0255. Periodicals postage paid at Farwell TX and additional mailing offices. POSTMASTER: Send address changes to: State Line Tribune, P.O. Box 255, Farwell TX 79325-0255. Pub. #520220. Rob Pomper, president Rebecca Pomper, vice president Texas Press Association Contact us at Tribune@plateautel.net Or visit online at www.statelinetribune.com

Ellis Funeral Home

Home-owned and serving this area since 1959.

104 E. Avenue F, Muleshoe

272-4574 • (800) 299-4574

NOTICE

to Parmer County Taxpayers

February 1, 2010, is the deadline to pay all personal and property taxes in Parmer County.

Checks must be postmarked by February 1, 2010, or penalty and interest will occur.

If you turned 65 years old as of January 1, 2010, then you need to sign up for the “65 and older” Homestead Exemption. This is a permanent exemption so if you already have signed up for it, you don't have to re-apply.

If you have purchased a home since you signed up for the Homestead Exemption, you need to re-apply for this exemption.

Agricultural use exemptions are available for all who have purchased agricultural property. If you purchased ag property during the past year, you need to apply for this exemption.

Vehicle exemption forms for those who qualify are available online at www.parmercad.org or come by our office to apply.

Call, or drop by our office, for your application(s). They will be mailed to you upon request.

Curby Brantley Chief Appraiser

Parmer County Appraisal District PO Box 56, Bovina TX 79009 (806) 251-1405

IntegraCare

HOME HEALTH & HOSPICE "Partners In Health"

Post Surgical and Wound Care Management

803B W. American Blvd., Muleshoe

806-272-6884

Nurse on call 24 hours, 7 days a week



January 2009

Your school board members are committed to public education and the continuing success of your students and schools.

Take time in January to thank your Farwell trustees for a job well done!

- Darren Haseloff – President
- Kendall Devault – Vice President
- Molly Stancell – Secretary
- Keith Hadley
- Scott Johnson
- Jay Be Barrett
- Willie Martin



Texas Association of School Boards • P.O. Box 400 • Austin, Texas 78767-0400



Showing our appreciation

January is School Board Recognition Month, with the goal of building awareness of the vital role an elected board of education plays in our society.

The Lazbuddie Independent School District is joining other districts throughout the state in recognizing the important contributions trustees make to their schools and communities.

Our school and community have benefitted by having a school board committed to excellence through a well-rounded program. We feel we have one of the finest programs in the state as a result of having had, consistently, a group of individuals who have only the highest expectations for students in all of their endeavors.

Our board gives considerable time and effort toward advancing our educational programs as well as making a strong commitment to local control and decision making in education.

Their efforts reflect a year-round commitment to our students, school and community. We are making a special effort this month to voice our appreciation for their services.

Please take a moment to tell a school board member “thanks” for a job well done toward the continuing success of our school and for caring about our students.

The school board members serving Lazbuddie I.S.D. are:

- Chris Timms – President
- Randy Smith – Secretary
- Mike Nichols
- Shannon Weaver
- Doyle Weir
- Brian Glover
- Daniel Schacher

44th Annual

Farwell FFA - 4-H Livestock Show

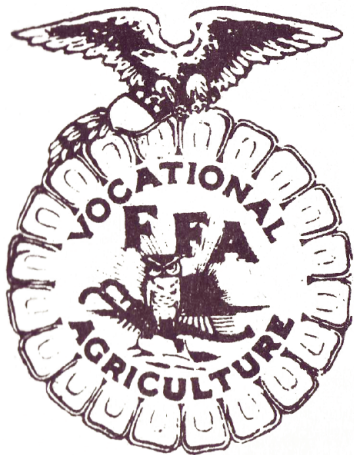

Saturday, Jan. 9th
11:00 a.m.
Farwell Community Center

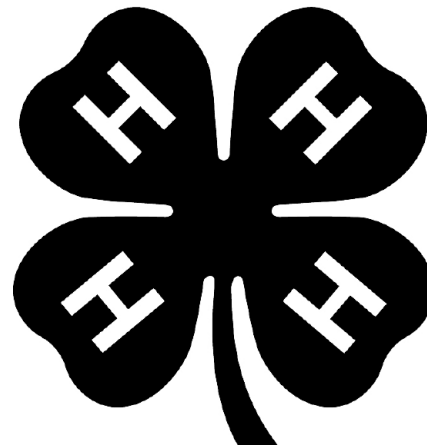

Classes:

Barrows - Lambs - Goats - Steers - Beef Heifers

Farwell 4-H will offer hot dog lunches at their concession stand!!



Belt Buckles to be awarded for each Grand Champion, Reserve Champion & Showmanship in each division



We congratulate our 2009 winners

Zac Stancell
 Beef Heifer Grand Champion

Drew Johnson
 Steers Grand Champion
 Barrows Grand Champion

Jill Johnson
 Barrows Reserve Champion

Katlin Martinez
 Beef Heifer Reserve Champion

Cari Johnson
 Steers Reserve Champion

Cambree Haseloff
 Barrows Showmanship

Ag Marketing & Management

308 3rd St. & Ave. D, Farwell
 481-2626 - (800) 748-2897

Specializing in commodity futures & options trading

Bryon Fillpot

Austin Mason
 Lambs Grand Champion

Michelle Wauson
 Goats Grand Champion
 Lambs Reserve Champion
 Sheep Showmanship

Mike Camp Insurance

509 Ave. A, Farwell
 481-9445

D-C Communication
 401 5th Street • P.O. Box 252
 Farwell, TX 79325
Find out whats new and what can be improved! Call David Cochran today.
 806-481-3883 or 505-760-7925 Cell

K'Leigh Jo White
 Goats Reserve Champion
 Goats Showmanship

Abby Johnson
 Steers Showmanship

Fransen Irrigation & Farwell Feed Supply

Farwell Hardware

305 Ave A • 481-3286

THE APPLE SHACK

715 FM 292 (North 9th Street)
 Farwell, Texas
 (806) 481-8682

Scott Johnson Farm Service

- Custom Farm Management
- Forage Harvesting
- Manure Spreading
- Commercial Trucking
- Chemical Application

Office: (806) 481-6655
 Cell: (505) 309-9400
 sjfs@plateautel.net
 www.sjfs.us

L & L Pallet Supply, Inc.

Owners: Tom Landry & Frank Landry
 272-5041

KELLY GREEN SEEDS

Kelly Green Seeds
 "We Grow For You"

FARWELL FUELS
 Serving Western Texas and Eastern New Mexico
 481-3222

Farwell Abstract Company

402 3rd St.
 (806) 481-3361

THE CITIZENS BANK OF CLOVIS

Texico Branch
 MEMBER FDIC

WILBUR-ELLIS COMPANY
 SOUTHERN U.S. & MEXICO BUSINESS UNIT

Box 667, Farwell

 (806) 481-3346
 IDEAS TO GROW WITH®

TIRE COUNTRY

Proud to support agriculture in Parmer County!

101 First Street - Farwell, Texas
 Office: (806) 481-9613 Cell: (806) 535-5967

LOWE'S Supermarket Farwell

Southwest AG SERVICES

Everything Agriculture
 Your headquarters for tools, farm supplies, and automotive parts!
 481-3295 • 1017 Ave. A, Farwell

Border Banter

--Mike Pomper

How a bureaucracy works ... or doesn't

Here we go again. This story never changes.

The story involving that Nigerian fella who tried to set off a bomb in an airplane over Detroit notes that his father tried to warn us of his terrorist tendencies.

The dad, it seems, told one of our CIA bureaucrats, who either ignored the advice or passed it on to a bureaucrat in another government agency who ignored it (depending on who is telling the story).

And the media is unhappy with the bureaucrat. But as our readers know, there is nothing to be unhappy about. We know that bureaucrats learn early to do nothing when a problem occurs.

The idea is to stay out of the problem by ignoring it. That is how they believe they can keep their high-paying jobs without doing much work.

I guarantee you that every bureaucrat in the U.S. is quietly applauding what the bureaucrat did (or failed to do, to be precise).

Government never acts ... it reacts.

Now that the bureaucrat knows the fella was a terrorist, he can act!

In fact, a week after the incident, the FBI and CIA were interviewing the terrorist's father. Now that is what I call staying on the ball!

Way to go, FBI and CIA.

That's the nature of the

beat.

Makes you want to throw up, doesn't it?

I assume by the time this column appears in print, that at least one "head will roll" due to this unbelievable stupidity. Well, it won't happen. What I predict is that the CIA bureaucrat who screwed up royally will be promoted!

Yep, that's how our government works. Sure puts a smile on your face, doesn't it?

And I'm not just talking of bureaucrats, our national politicians fall into the same trap. The health insurance mess is a perfect example.

If our "leaders" (and I use the term loosely) had acted years ago on health insurance, it would never have gotten to the current time of crisis.

In a perfect world, the GOP and Democrat leaders in Congress years ago could have set up a bi-partisan committee to deal with the upcoming health insurance problems that were not only leaving millions of Americans uninsured, but also causing a growing financial dilemma for companies that afforded their employees health insurance.

Surely, they were aware of it. Heck, I was writing columns over 20 years ago of this problem coming down the road.

But, obviously, they chose to stick their heads in the sand.

Government never acts ... it reacts.

So now we have a full-blown crisis with major companies having to lay off employees because they cannot afford them health insurance, and, voile, our government is acting.

It scares the heck out of me to find out what bill is finally approved in conference, then is signed into law by President Obama. Who will pay for their trillion-dollar fiasco?

What was needed was

for insurance coverage to be put into effect on a piecemeal basis over a period of time. That way we could have afforded it. That would have worked out very well.

But, no, our "leaders" couldn't do the intelligent thing. They had to wait until Chicken Little cried "the sky is falling" before they would act.

Of course, why should our "leaders" care about the little man. Heck, 44 percent of our U.S. Senators and Congressmen are millionaires.

Well, I'm not a millionaire and I never will be. And looking back at the lousy health insurance my family had over many years because I could not afford decent coverage makes me angry.

And I will never forget the difficulty I had getting insurance for my daughter because she had a "pre-existing condition."

Nor will I forget the Farwell man who was very ill and had no insurance coverage because he couldn't afford it. He cried right in front of me at the Tribune office. And a month later he was dead.

My fantasy is that all our Congressmen and Senators lose their full free family health insurance coverage, and then we would see what their reactions were.

Heck, our "leaders" even keep their own private doctors housed at Capital Hill so they are on-call whenever needed.

Do any readers of this column work somewhere where physicians have their offices (not counting a medical facility, of course).

The answer is no way; no small business could afford that luxury.

Did I say "nobody?" Well, excuse me, I forgot about our piggish Senators and Congressmen.

While I supported our Presidents (Bush and Obama) in using stimulus money for our econo-

my in a time to prevent another major Depression, I do not support a health insurance "solution" that is anything but.

It's bad enough that our children and grandchildren will have to pay off the stimulus debt, but to double the debt to pay for health insurance is a crime against the American people.

And there's not a damn thing we can do about it.

*** This short note is especially addressed to our readers who have moved away from Farwell:

The Tribune will be working hard in the coming weeks and months to publicize the need to raise funds for the obelisk, which would re-establish an important part of Farwell's history.

Even though you may have moved away awhile back, please help - all donations will be appreciated.

Just send your check to the Farwell Obelisk Fund, in care of Security State Bank, Drawer J, Farwell TX 79325.

*** I know that former Texas Tech Coach Mike Leach marches to a different drummer and is difficult to work with.

And I know that he and Tech Athletic Director Gerald Myers have been at odds.

I further know that I don't know all the facts in the case that got Leach fired so I cannot make a decent judgment on whether the firing was warranted.

But I do know that Tech's football program will never be the same.

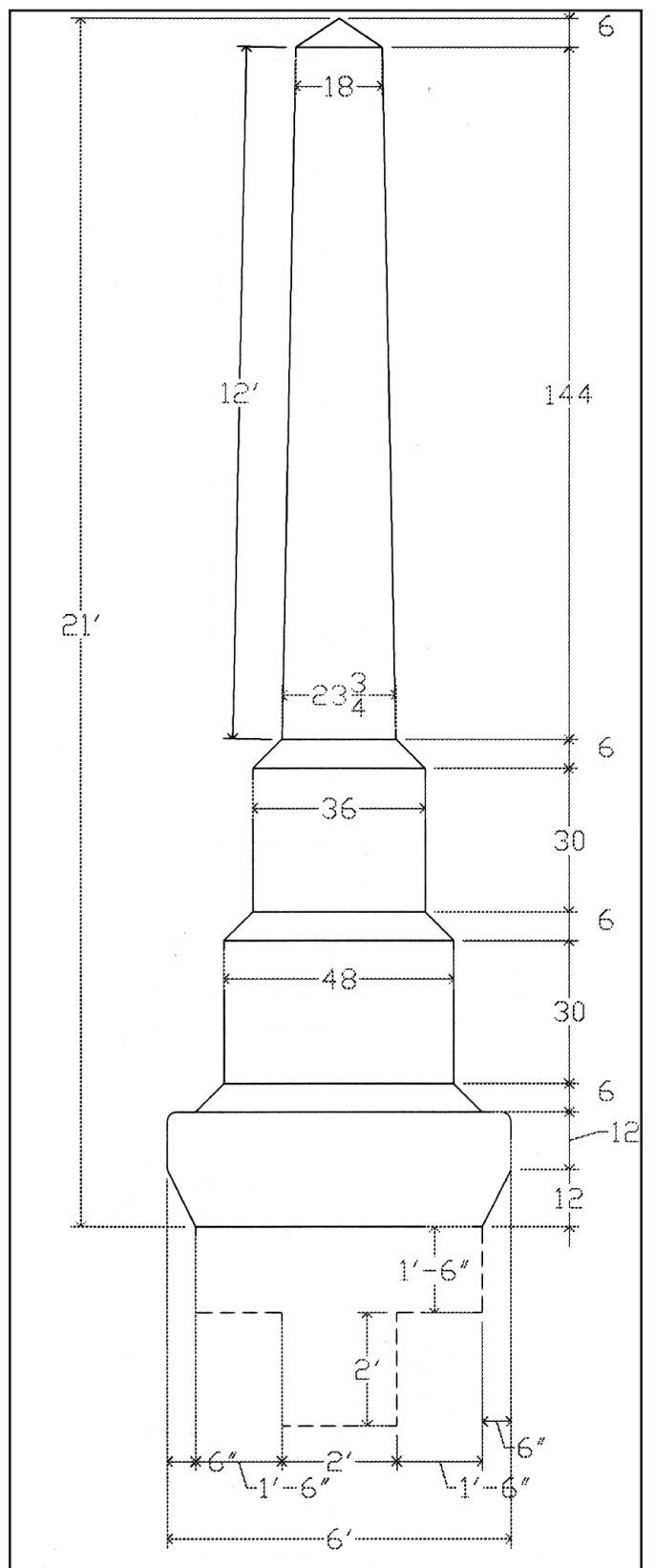

Fund started for obelisk

Here are the exact dimensions for the Farwell obelisk that will be replicated if the fund drive goes well. If you can send a donation for it, please make out the check to "Farwell Obelisk Fund," in care of Security State Bank, Drawer J, Farwell, Tx 79325, or drop off a check at the bank on 5th Street. The Tribune will carry periodic updates on how the fund drive is going.

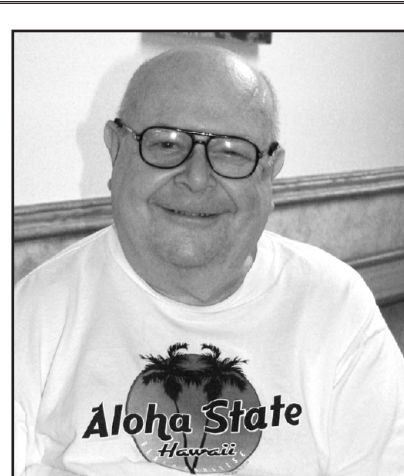

Our People Make The Difference!

Jimmie "Flash" Gordon Resident

**Farwell Convalescent Center
305 5th St. 481-9027**

Offering: Skilled Nursing Care, In-Patient & Out-Patient Therapy, Meals on Wheels & Independent Seniors Apartments. Call Today for more information!

THREE-WAY CALLING

Want to save time planning events, increase your productivity and stop wasting time?

With three-way calling you can talk to two different people, in two different places, at one time--even if the person you are calling is long distance!

To add Three-way calling to your service, or for more information on this call our office at 250-5555.

WT Services Inc.
1010 Columbia, 250-5555, Friona, Texas 79035

We Sharpen Knives

SOUTHWEST

AG

Farm Supplies Auto Parts & Hardware

Your headquarters for tools, farm supplies, and automotive parts!

Come see us today!

**Toll Free 1-866-481-3295 • 1017 Ave. A • Box 166
Local 806-481-3295 • Farwell, Texas 79325**

Auction Calendar

Tuesday, January 12, 2010 - Sale Time: 9:00 a.m.
Bishop Farms—Owner
Located: Edmonson, Texas - Selling: Combines, Cotton Equipment, Tractors, Trucks, Farm Equipment

Wednesday, January 13, 2010—Sale Time: 9:30 a.m.
Squires Farms—Owners
Located: Springlake, Texas—Selling: Combines, Cotton Equipment, Tractors, Trucks, Farm Equipment

Thursday, January 14, 2010—Sale Time: 10:00 a.m.
Jeff Rainey Estate—Owners
Located: Lamesa, Texas—Selling: Tractors, Cotton Equipment, Farm Equipment

Saturday, January 16, 2010—Sale Time: 10:00 a.m.
Bobby Pool—Owner
Located: Groom, Texas—Selling: Farm Equipment

Tuesday, January 19, 2010—Sale Time: 10:00 a.m.
Barker Farms—Owners
Located: Plainview, Texas—Selling: 160 Acres Dry Land, Farm Equipment, Hog Equipment

Wednesday, January 27, 2010—Sale Time: 10:00 a.m.
Jerry Ford—Owner
Located: Lockney, Texas—Selling: Cotton Equipment, Tractors, Farm Equipment

Saturday, January 30, 2010—Sale Time: 10:00 a.m.
Mitchell Farms—Owner
Located: Hart, Texas—Selling: Tractors, Cotton Equipment, Farm Equipment

JIM SUMNERS.....(806) 864-3611
(1006)
(HOME)

JIMMY REEVES.....(806) 864-3362
(Clerk)
(HOME)

DONNA NOEL.....(806) 293-1124
(Secretary)
(HOME)

Please Bring Bank Letter.

Five Star Auctioneers

OFFICE: (806) 296-0379 — P. O. BOX 1030 — PLAINVIEW, TEXAS 79073-1030

WEB SITE: WWW.FIVESTARAUCIONEERS.COM

Terms of Sale: Cash, Personal or Business Check, Cashier's Check
All Accounts Settled Day of Sale — Lunch Will Be Available

NOTE: Please Bring Your Own Check Book. If You Have Not Established Yourself With Our Company,

Wind farm project reality moves closer

By Gina Prather

Jim Swafford, a Texan born and raised, had a dream to build a wind farm right here in Parmer County. Bit by bit, over the past four years he has chipped away at every challenge set before him and is now beginning to see his dream come true.

"Once the idea came to me about a wind farm in Parmer County, I began researching it on the internet trying to figure out what to do first. Before too long it became crystal clear what the key was. Wind data," Swafford said.

Swafford established his company Premium Wind Coalition Company and the work began.

With the support of the City of Bovina and the Bovina Economic Development Board, anemometers were installed on a hundred meter tower and the collection of wind data began. This was the beginning, the first step in attracting a wind developer to the county, solid proof that there was reliable wind here.

Over the years, developers came to Parmer County, looked around and said the same thing. The wind was great; the land was great but ... no grid. There was no electrical infrastructure to ship the power out of Parmer County. The developers would just shrug and walk, always saying the same thing, it will come but it's not here yet.

On Feb. 1, 2009, two wind developers from Denmark and Norway, Jens Peterson and Harald Dirdal, came to Bovina at Swafford's invitation. They were amazed at the potential Parmer County had to offer. From the very first moments of their visit it was clear that these men had a different viewpoint. Their philosophies were building it right, and build it big, so big that the grid companies have to pay attention. Thus, Scandia Wind Southwest and the Mariah Project were born.

Dedicated to the idea of developing a wind farm in Parmer County, Bovina saw a lot of Peterson and Dirdal over the summer. The first order of business was to erect more sophisticated wind anemometers in the county. Two different towers were chosen and up to 12 anemometers were mounted. Peterson spent up to 15 hours straight in a harness up on the towers in 103 degree temperatures to get the job done. There was even an encounter with a rattlesnake during the process.

The second order of business was to understand and make Scandia Wind a common name in the political arena. Last spring, Dirdal, Kay and Jim Swafford, and Mike Prather traveled to Austin to meet with several politicians in an effort to get support for the Mariah Project.

The third and most daunting order of business was to conquer the grid issue. Scandia Wind established a series of meetings with grid expert Debbie Lewis of RnR Engineering; and folks from Sherry Land Utilities, a branch of Hunt Transmission Services; AEP; Southwest Power Pool, and Golden Spread Electric Co-op.

Dirdal and Prather also traveled to other states, meeting with top level officials in these companies,

promoting the Mariah Project ... and getting positive responses. Scandia Wind has made a grid application to ERCOT for 1,000 megawatts, which may be increased to 1,250 megawatts.

The most encouraging grid option is with Tres Amigas LLC, an interconnecting super station being built north of Clovis.

Tres Amigas is a company with the potential of shipping huge amounts of electricity all over the nation. Last fall, Dirdal and Prather met with Phillip Harris, the CEO of Tres Amigas, in Albuquerque. This began a series of communications with Tres Amigas, which has culminated in a letter of intent. Currently, a formal agreement is being drawn up between Tres Amigas and Scandia Wind Southwest to be instigated in the next six months.

The fourth business challenge was to communicate with landowners in Parmer County. It was crucial to give information about the project to them and to have their support. Thus, the Parmerton Rhea LLC was established.

A steering committee was put into place led by Mindy Neal Widner. This committee volunteered their time in order to see the Mariah Project become a reality. Countless hours were spent negotiating a lease agreement that is fair and good for the landowners.

On Nov. 30, a land lease-signing event took place in Farwell. More than 100 landowners attended. Many signing their leases on the spot. An all-out effort to sign up as many acres as possible has occurred since then, led by Swafford.

To date, about 78,000 acres have been signed up. It is crucial for landowners who are inside the boundaries of the Mariah Project and want to become part of it, to obtain a land lease, sign it and send it in as soon as possible.

Any landowners who cannot get their leases in or have questions about the project are asked to call Swafford.

Sheriff's Report

Here is the weekly report from Parmer County Sheriff Randy Geries:

On Dec. 28, Heath Sneed, 35, of Roswell, N.M., was arrested by the sheriff's office on a charge of DWI with child, pending in district court.

On Jan. 1, Benito Ortiz, 32, of Friona, was arrested by Texas Highway Patrol on a charge of DWI 2nd, pending in county court.

On Jan. 1, Javier Sanchez, 23, of Friona,

was arrested by the sheriff's office on a charge of public intoxication. He was fined \$250.

Obituary

Leonard Watkins

Rev. Leonard Watkins, 81, of Stockton, Calif., died Jan. 1.

He was born June 22, 1928, in Canute, Okla., to G.T. and Nina Watkins.

As a pastor, he served churches in Texas, California and Oregon for 54 years.

Surviving are his wife, Susan; children Janita Wright, of Floydada,

Texas; Sherri Schroeder, of North Bend, Ore., and Dee Victorino, of Stockton; stepchildren, Wendy Brasher and Gena Fenn, both of Alabama; brother, Donald Watkins of Farwell; 5 grandchildren and 5 step-grandchildren and 2 great-grandchildren.

Services will be held Jan. 8 in Stockton.

BB arrests anticipated

There is still nothing more to report on the Clovis man who died in December in Farwell.

Police Chief Larry Kelsay said the death involved narcotics and he is awaiting the autopsy report.

Kelsay also reported he is continuing work on the suspects apprehended after the BB shooting spree and arrests are expected to be made this week.



Elect Linda Moss Hardy

Justice of the Peace

Republican Candidate · Precinct #3

Served Everyone at Farwell Independent School District for 31 Years

"Let me serve you again as Justice of the Peace"

Pd. political ad by candidate

Dedication, hard work, study, sweat, cleaning, more work, long hours, teaching, more cleaning, stock shows, longer hours, more work, more cleaning, more study, sweat and work.

Is it worth it?

Yes.

We are proud of all of the kids that put in so many hours, and work so hard to raise their animals and show them across the state of Texas. Congratulations on getting this far, and best of luck at the shows in your future.



- Custom Farm Management
- Forage Harvesting
- Commercial Trucking
- Chemical Application

Office: (806) 481-6655
Cell: (505) 309-9400

sjfs@plateautel.net
www.sjfs.us

120 US Hwy 84, Farwell

End of the season savings!

Come in before Jan. 15 for some great deals!

20% Off From now until Jan. 9

40% Off From Jan. 11 thru Jan. 15

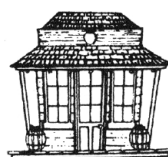

THE APPLE SHACK

715 FM 292 (North 9th Street)
Farwell, Texas
(806) 481-8682

Dairy Direct
2508 N. Prince #312
Clovis, NM 88101
Office: (575) 762-7997
Mobile: (575) 714-3745
Fax: (575) 762-7466
dairydirect@plateautel.net
Craig & Jeannette Albin

United Supermarkets
Muleshoe

MULESHOE LIVESTOCK AUCTION
Muleshoe, TX • Sale Every Saturday
Clayton, C.L. & Thurman Myers • 272-4201

DON POOL CONSTRUCTION
AND COLORADO RIVER CONCRETE
P.O. Box 2103
Clovis, NM 88102
GB 98 • License 88304 Office (575) 742-2000

Parmer County Cotton Growers Co-op
(806) 825-3701

Five Area Telephone Cooperative
(806) 272-5533
302 Uvalde Muleshoe, TX

Farmers' Electric Cooperative, Inc.
"Owned By Those We Serve"

Farwell Feed Yards
(806) 481-3324

High Plains Federal Credit Union
Where you belong

STATE LINE Photography
481-3681

VALLEY Franse Irrigation
(806) 481-3316

Please attend church services

Oklahoma Lane Methodist Church
Worship Service -- 9 a.m.
Sunday School - 10 a.m.

First Baptist Church of Texico
Rob Hollis - minister
Sunday School - 9 a.m.
Worship-10:15 a.m., 5:30 p.m.
Wednesday - 7 p.m.

Hamlin Memorial United Methodist Church
Sunday School - 10 a.m.
Worship - 11 a.m. & 6 p.m.

Assembly of God Church, Texico
Bob Burris - minister
Sunday School - 9:15 a.m.
Worship - 10:15 a.m. & 6 p.m.
Wednesday - 6 p.m.

First Baptist Church Of Bovina
Sunday School - 9:45 a.m.
Worship - 11 a.m.
Wednesday worship & youth, 7 p.m.

Farwell Convalescent Center
Sunday services -- 9 a.m.
Bible study - 9:30 a.m. Friday

St. John Lutheran Church, Lariat
David Symm - minister
Worship Service - 9:30 a.m.
Sunday School - 10:30 a.m.

Pleasant Hill Baptist Church
Jim Peabody - minister
Sunday School - 9:45 a.m.
Worship-10:30 a.m., 6:30 p.m.
Wednesday - 6:30 p.m. winter
7:30 p.m. summer

Lariat Church of Christ
Wesley Roach - minister
Sunday School - 10 a.m.
Worship - 10:45 a.m. & 6 p.m.
Wednesday - 7 p.m. winter
8 p.m. summer

Iglesia Bautista Hispana in Bovina
Rafael Marin, pastor
Sunday School - 9:30 a.m.
Worship - 11 a.m.
Wednesday worship, 7 p.m.

Lazbuddie Church of Christ
Mickey Chambiss - minister
Sunday School - 9:30 a.m.
Worship - 10:20 a.m. & 5 p.m.
Wednesday -- 7 p.m.

Bovina Church of Christ
Mike Prather, minister
Sun. - Bible study - 9:45 a.m.
Sun. - Worship - 10:45 a.m.
Wed. - Bible class - 7 p.m.

Lazbuddie Methodist Church
Rev. Ken Peterson
Sunday School -- 9:30 a.m.
Worship -- 10:30 a.m.

San Jose Catholic Church, Texico
Sunday Mass - Noon
Religious Education - 1:15 - 2:15 p.m.
Community Meal -- 1:15 p.m.

Church of Christ
110 Ninth St.
Sunday School - 10 a.m.
Worship - 11 a.m. & 6 p.m.
Wednesday - 7 p.m. summer
8 p.m. winter

Bovina United Methodist Church
Sunday School - 9:45
Worship - 11 a.m. & 6 p.m.
Wednesday study, 7 p.m.

Apostolic Truth United Pentecostal Church of Texico
Sunday School - 9:30 a.m. mt
Worship - 11:15 a.m., 5:30 p.m. mt
Wednesday - 7 p.m. mt

St. Ann's Catholic Church
Rev. Wm. Yeddapanalli
Sunday Mass: 8:30 a.m. in English;
10:45 a.m. in Spanish
CCD - 9:30 a.m.
Evening Mass: 6 p.m. Wednesday & Friday

First Baptist Church of Lazbuddie

Church of God in Christ Mennonite Farwell Country Church
James Koehn, Orie Nightingale - ministers
Sunday School - 10 a.m.
Worship Service - 11 a.m.

First Baptist Church of Farwell
Sunday School -- 9:45 a.m.
Worship -- 11 a.m. & 6 p.m.
Children & Youth -- 5:45 p.m.
Wed. Prayer meeting - 6:30 p.m.
www.fbclfarwell.org

Farwell Church of Christ
Phillip Steyn -- preacher
Bible Class Sunday - 10 a.m.
Worship; 10:50 a.m. & 6 p.m.
Wednesday - 7:30 p.m.
In Search -- 7:30 -- Ch. 4 Sun.

New Light Missionary Baptist Church
Rev. Briyan Phillips Sr.
Sunday School - 9:30 a.m. mst
Worship - 11 a.m. mst
Bible Study - Wednesday at 6:30 p.m. mst

St. Ann's Catholic Church
Rev. Wm. Yeddapanalli
Sunday Mass: 8:30 a.m. in English;
10:45 a.m. in Spanish
CCD - 9:30 a.m.
Evening Mass: 6 p.m. Wednesday & Friday

CLOVIS VETERINARY SUPPLY
CARROLL LEATHERWOOD
Veterinary Supplies
2108 W. 7th
Clovis, NM 88101 (575) 762-1200

K. Barnett & Sons
Offering construction services
2405 W. 7th St., Clovis
(575) 762-4407

Agri-Plan, Inc.
Crop Insurance
109 3rd St. Bovina • 251-1167

West Texas Rural Telephone
COOPERATIVE INCORPORATED
(806) 364-3331
P.O. Box 1737, Hereford TX 79445

roden-smith pharmacy
RODEN-SMITH VILLAGE - 801 E. LLANO ESTACADO
CLOVIS, NM 88101
PHONE 762-3848
David Lansford, R. Ph. - owner/manager

Lowe's Supermarket

"We Grow For You"
KELLY GREEN SEEDS
All Varieties Small Grain Seeds
Wheat - Barley
Oats - Rye

BCEC Bailey County Electric Cooperative Association

2100 N. Martin Luther King, Jr. Blvd. (575) 769-2141
Plains Regional Medical Center
Home Health/Hospice
PREBYTERIAN www.pbs.org

Steed-Todd Funeral Home
"When Understanding Is Needed Most"
Prince & Manana - Clovis - 763-5541

Experience the Hometown.
The Bank of Clovis

Farwell Elementary honor rolls listed

Farwell Elementary School honor rolls for the 3rd six weeks:

Barnes – honor roll, Sterling Henderson, Patrick Pena, Trace Stancell, Katey White; achievement list, Wendy Gaxiola, Kylie Haseloff, Sage Klein, Ramon Reyes, Roberto Trevizo.

Beauchamp – honor roll, Eric Barrera; achievement list, Joue Alonso, Danny Dyck, Matthew Dale, Hope Herrera, Leslie Mora, Brooke Mullin, Alexis Olmos, Luis Solis, Mariana Sosa, Ethan Stancell.

Gipson – honor roll, Romeo Reyes, Miguel Vasquez; achievement list, Mason Byrd, Brandon Galvan, Sailor Jackson, Alexia Nicolas, Mauricio Vidana, Andrea Chavez-Murillo, Marivel Galvan, John Mitchell, Ricardo Torres, Lisa Zacharias.

Parker – honor roll, Cameron Bass, Garrett Schilling, Mallory Schilling, Edie White; achievement list, Izaiah Benoit, Sarah Gomez, Antonio Lopez, McKenzie Parra, Rachel Stinson.

O'Hare – honor roll, Kenlea Barnes, Heath Hadley, Jace Perkins; achievement list, Jackie Amador, Lindsi Coburn, Treylin Griswold, Lauren Isaacson, Peyton Ledbetter, Joseph Ortega, Meredith Ratke.

Allen – honor roll, Christian Barrett, Jackson Jarman, Kinley Kalbas, Matthew Kube, Estfany Plascencia, Brittnei Soto, Jordan Villarreal; achievement list, Elisha Carrasco, Jasmine Corona, Ivory Hernandez, Jack Isaacson, Sydney McClaran, Aaron Meza, Ricardo Ortega, Brianna Reyes, Leonel Ruiz, Isaias Sotelo.



Bailey sets school record

Varsity Girls

The Lady Wolverines took 3rd place in the Plateau Tournament with a loss to Clovis, 60-51.

The Lady Wolverines, 7-6, played three New Mexico Class 5A schools in the tourney.

Scoring were Katlin

Luscombe, 8; Victoria Richards, 5; Shaylee Anderson, 4; Shannon Van Matre, 2; Jordyn Cooper, 9, and Jaylyn Cooper, 13.

Varsity Boys

The Wolverines stayed undefeated at 9-0 with an 81-58 win over Hagerman

last weekend.

Scoring were Quin Winkles, 2; Jose Posada, 6; Connor Doolittle, 2; Marques Pena, 6; Lucas Walthers, 15; Seth Bailey, 39; Mitchell Harrison, 2;

Lazbuddie JV Boys Tournament

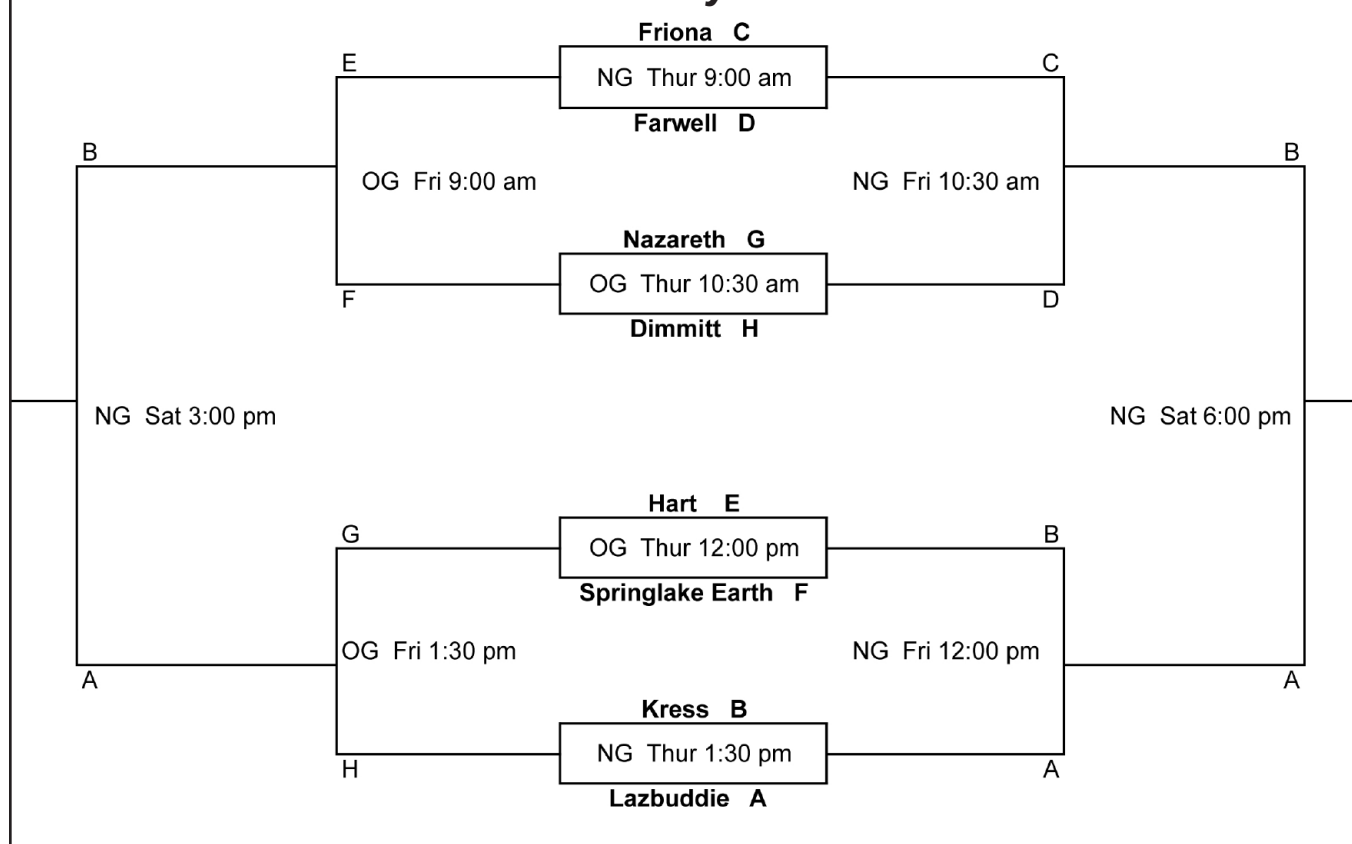

Lazbuddie JV Girls Tournament

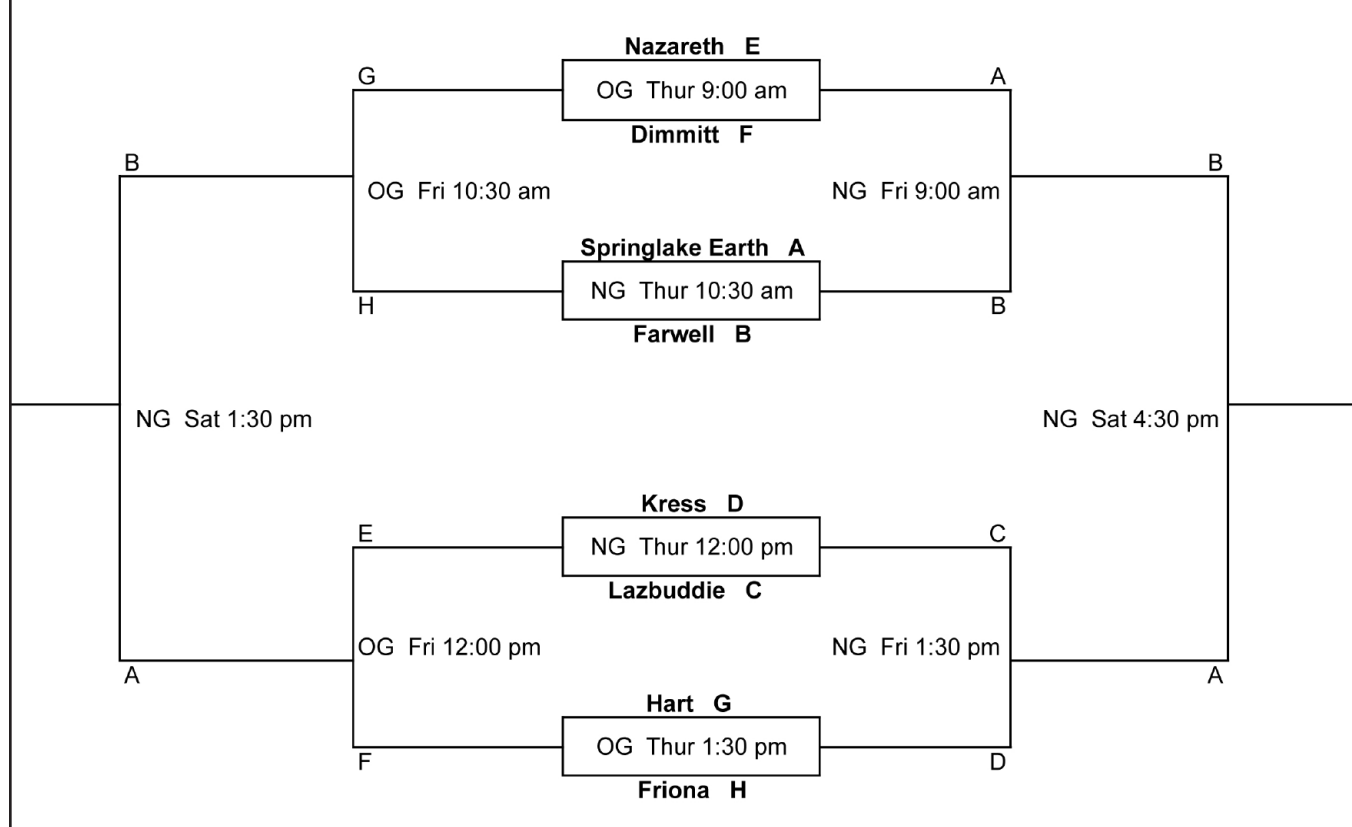

NEED PROPANE?

Dependable service ** Competitive pricing
Call 481-3222 or 251-1284

Also, toll free, Farwell (877) 467-9261 • Bovina (877) 467-9271

WE'RE PROUD



...of our youth
...of our community

Show your support at the
**Friona Community Center
Showbarn**

**62nd Annual Parmer County
Junior Livestock Show**
January 13-16



Grain Marketing, Inc.

Toll Free – 1-866-583-7362

And good luck to all of the kids who have put in so much time and effort. No matter what livestock show you are participating in, either Farwell, Lazbuddie, Parmer County, Bailey County or any of the others in the state, do your best and know that all of us at AGP are proud of you.

Statement of Non-Discrimination

West Texas Rural Telephone Cooperative, Incorporated, is the recipient of Federal financial assistance from the Rural Utilities Service (RUS), an agency of the U.S. Department of Agriculture, and is subject to the provisions of Title VI of the Civil Rights Act of 1964, as amended, Section 504 of the Rehabilitation Act of 1973, as amended, the Age Discrimination Act of 1975, as amended, and the rules and regulations of the U.S. Department of Agriculture which provide that no person in the United States on the basis of race, color, national origin, age, handicap, sex, marital status, income level, source of income, or geographic location shall be excluded from participation in, admission or access to, denied the benefits of, or otherwise be subjected to discrimination under any of this organization's programs or activities.

The person responsible for coordinating this organization's non-discrimination compliance efforts is Jimmy Bell, Assistant Manager.

Any individual, or specific class of individuals, who feel that this organization has subjected them to discrimination may obtain further information about the statutes and regulations listed above from and/or file a written complaint with this organization; or the Secretary, U.S. Department of Agriculture, Washington, D.C. 20250; or the Administrator, Rural Utilities Service, Washington, D.C. 20250. Complaints must be filed within 180 days after the alleged discrimination. Confidentiality will be maintained to the extent possible.

West Texas Rural Telephone
COOPERATIVE INCORPORATED

(806) 364-3331

P.O. Box 1737, Hereford TX 79045

Here's a look at past Farwell Stock Show champions

The first Farwell Junior Livestock Show was held in 1966. Jerry Mathis was the FFA instructor. Don Geris was show superintendent. Fred Chandler was the arena director. Joe Van Zandt was the county agent.

Here's a look back at the Farwell stock show winners:

- 1966 - Randy Johnson, barrows; Jerry Ford, gilts.
- 1967 - Jacquelyn Langford, steers; Dennis Ensore, lambs; Randy Crook, barrows; Craig Phillips, gilts.
- 1968 - Larry Jones, steers; Debra Harding, lambs; Mark Williams, barrows; Doug Harriman, gilts.
- 1969 - Harold Jones, steers; Lori Norton, lambs; Robert Haseloff, barrows; Mike Flowers, gilts.
- 1970 - Larry Jones, steers; Jay Herington, lambs; Edward Terry, barrows; Darwin Green, gilts.
- 1971 - Joe Haseloff, steers; Debra Harding, lambs; David Garner, barrows; Mike Flowers, gilts.
- 1972 - Mac Langford, steers; Debra Harding, lambs; Paul Brigham, barrows; Mack McFarland, heifers.
- 1973 - Annette Langford, steers; Mark Haseloff, barrows; Dwight Green, gilts.
- 1974 - Jacquelyn Langford, steers; Conda Jones, lambs; Paul Brigham, barrows.
- 1975 - Mark Haseloff, steers; Lori Norton, lambs; Paul Brigham, barrows.
- 1976 - Gary Haseloff, steers; Joe Haseloff, heifers; Lori Norton, lambs; Vick Christian, barrows.
- 1977 - Gary Haseloff, steers; Ken Foster, lambs; Brent Green, barrows.
- 1978 - Mac Langford, steers; Todd Meeks, lambs; Brent Green, barrows.
- 1979 - Mac Langford, steers; Todd Meeks, lambs; Mark Owen, barrows.
- 1980 - Gary Haseloff, steers; Joanna Mesman, lambs; Mark Owen, barrows; Kevin Owen, gilts.
- 1981 - Gary Haseloff, steers; Corey Jones, lambs; Brent Green, barrows; Dana Ralston, gilts.
- 1982 - Gary Haseloff, steers; Corey Jones, lambs; Jeff Rhodes, barrows; Kevin Owen, gilts.
- 1983 - Gary Haseloff, steers; Danna Ralston, barrows; Danna Ralston, gilts.
- 1984 - Darren Haseloff, steers; Kendra Stephens, lambs; Carl Hutchins, heifers; Geretta Hutchins, barrows; Daniel Hutchins, gilts; Trent Schilling, goats.
- 1985 - Darren Haseloff, steers; Erik Burton, lambs; Amy Woodson, barrows; Sean Childers, gilts; Clint Kelley, goats.
- 1986 - Carl Hutchins, steers; Jacque Sides, lambs; Leonard Hillock, barrows; Lisa Geris, gilts.
- 1987 - Darren Haseloff, steers; Erik Burton, lambs; Randy Davis, barrows; Steve Geris, gilts.
- 1988 - Amy Hartzog, heifers; Clint Kelley, lambs; Brandi Norvell, barrows; Kip Atwell, gilts.
- 1989 - Klay Camp, lambs; Lyndi Austin, barrows.
- 1990 - Kara Camp, lambs; Reace Bennett, barrows.
- 1991 - Amy Hartzog, heifers; Sarah Montgomery, lambs; Brett Curtis, barrows.
- 1992 - Watson Langford, heifers; Klay Camp, lambs; Clint Patterson, barrows.
- 1993 - Candy Davis, heifers; Melody Montgomery, lambs; Clint Patterson, barrows.
- 1994 - Lyndi Austin, steers; Klay Camp, lambs; Dustin Bartlett, barrows.
- 1995 - Duane Haseloff, steers; Amy Hartzog, heifers; Brittany Pottorf, lambs; Dustin Bartlett, barrows.
- 1996 - Sam Billingsley, barrows; Karissa Foster, lambs; Erica DeLeon, steers.
- 1997 - Clint Patterson, steers; Jason Sudderth, lambs; Angela Billingsley, barrows.
- 1998 - Matt Schwertner, steers; Karissa Foster,

goats; Gaylen Sudderth, lambs; Mark Lunsford, barrows.

1999 - Luke Schwertner, steers; Ashlie Martin, goats; Clint Patterson, lambs; Marni Lunsford, barrows.

2000 - Matt Schwertner, steers; D'Anna DeLeon, lambs; Angela Billingsley, goats; Jennifer DeLeon, barrows.

2001 - Kari Schilling, steers; Karissa Foster, lambs; Karli Schilling, goats; D'Anna DeLeon, barrows.

2002 - Matt Billingsley, goats; Jake Ware, lambs; D'Anna DeLeon, barrows.

2003 - Ryan DeLeon, barrows; Matt Billingsley, goats; Khallie Foster, lambs.

2004 - Hayden Hadley, steers; Matt Billingsley, goats; Tyler Cullison, lambs; Ray White, barrows.

2005 winners: Ray White, Goats Grand Champion; Kade Foster, Lambs Grand Champion and Lambs Showmanship; Levi McCormick, Barrows Grand Champion; Dalton Cockerham, Steers Grand Champion; K'Leigh Jo White, Goats Reserve Champion; Tyler Cullison, Lambs Reserve Champion; Jill Johnson, Barrows Reserve Champion; and Hayden Hadley, Steers Reserve Champion and Steers Showmanship.

2006 -- Ray White, goats grand champion; Tyler Cullison, sheep grand champion; Lincoln Devault, barrows grand champion; K'Leigh Jo White, goats reserve champion; Kayla Cullison, sheep reserve champion; Tyler Schilling, barrows reserve champi-

on; Roper Ledbetter, heifer grand champion; Hayden Hadley, steer grand champion.

2007 -- Heifers: Drew Johnson, Beef heifer Grand Champion; Bretton Stancell, Dairy Heifer Grand Champion; Steers: Drew Johnson, Grand Champion; and Abby Johnson, Reserve Champion; Sheep: Colton Morris, Grand Champion; and Emily Agee, Reserve Champion; Goats: K'Leigh Jo White, Grand Champion; and Levi McCormick, Reserve Champion; Barrows: Ryan DeLeon, Grand Champion; and Cari Johnson, Reserve Champion.

2008 -- Goats: K'Leigh Jo White, Grand Champion; and Michelle Wauson, Reserve Champion; Lambs: Koltan Morris, Grand Champion and Reserve Champion; Barrows: Abby Johnson, Grand Champion; and Cambree Haseloff, Reserve Champion; Steers: Abby Johnson, Grand Champion, and Jill Johnson, Reserve Champion; Beef Heifer: Trevor Owen, Grand Champion.

2009 -- Beef Heifer: Zac Stancell, Grand Champion, and Katlin Martinez, Reserve Champion; Steers: Drew Johnson, Grand Champion, and Cari Johnson, Reserve Champion; Sheep: Austin Mason, Grand Champion, and Michelle Wauson, Reserve Champion; Goats: Michelle Wauson, Grand Champion, and K'Leigh Jo White, Reserve Champion; Barrows: Drew Johnson, Grand Champion, and Jill Johnson, Reserve Champion.

Meet Texico's Class of 2022

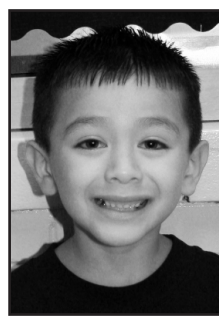

Juan Hernandez is a Texico kindergarten. His birthday is March 8. Parents are Raul & Monica Hernandez. Siblings are Paul, Brendon & Ariana. Grandparents are Rosendo & Diana Chavez, Pablo & Maria Rivera. He likes to wrestle, box, play football, play with wrestling toys, and ride his bike. His favorite color is green. His favorite foods are pizza, ice cream and veggies.

Sponsored by the Texico Branch of the Citizens Bank of Clovis

The Latest

Sales have begun for the Parmer County History Book, 3rd edition.

Pre-published price is \$45 with \$3.50 postage if the book must be mailed. Payment must be received before Feb. 1; afterward, they cost \$50. Books are expected in by early February.

Books can be ordered from Sharon White at 265-3874, Bonnie Howard at 481-9023, or Gladys Spring at 251-1552.

Gift cards are available. Be sure to request a gift card should one or more be needed.

Lazbuddie School will have an enchilada luncheon Sunday, Jan. 10 from 11 a.m. to 2 p.m. to raise funds for updating the library.

The meal will consist of 3 enchiladas, beans, rice, salad, chips, salsa, tea and homemade desserts. Admission is a donation to the library fund.

Texico police report all quiet last week.

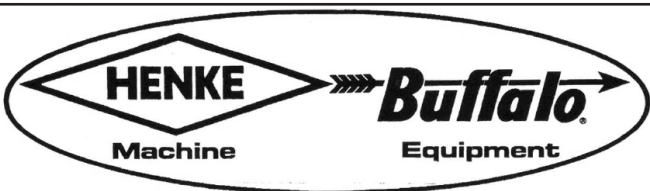

ROLLING STALK CHOPPER

Economical, Effective Residue Management!!

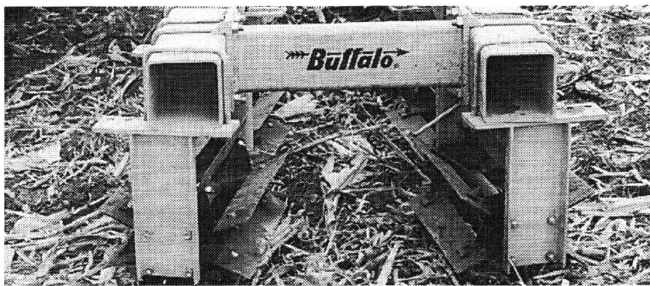

Prepare Fields — Conserve Moisture!

- Reduce Tillage — Save Moisture!
- Adjustable blade angles.
- Sizes from 2- to 16-row.
- Optional spike-tooth or chain-link harrow.

Fast, economical, simple — hitch to your three-point and go! Eliminate the worries and hassles of U-joints, gearboxes, drive assemblies, hydraulic hookups and PTO junctions.

See Your Dealer Today!!

DALE GALLMAN EQUIPMENT
One-Half Mile South of Bovina on FM 1731
(806) 238-1228

Henke Machine*Buffalo Equipment

Columbus, NE

50 YEARS AGO THIS WEEK

E.G. Phipps seeks re-election as Friona area county commissioner.

A coffee honors Mrs. Lee Jamison.

Larry Johnson wins statewide sorghum prize.

Jimmie Webb and Harvey Winkles, both 10, tangle with a skunk while hunting.

A housewarming is given Mr. and Mrs. Ed Combs.

Glendon Moss is honored with a hot dog supper for his 16th birthday.

Franse Irrigation

Farwell • 481-3316



Best Wishes to the 4-H and FFA Youth who will be exhibiting at the Parmer County Junior Livestock Show

Jan. 13-16

Friona State Bank

(806) 250-5000 www.frionastatebank.com

Be job ready at graduation ...



by enrolling in the Industrial Technology Plant Operations or Wind Energy Program!

Spring classes start January 19, 2010

For more information, call 575.769.4747



417 Schepps Boulevard
Clovis, NM 88101

www.clovis.edu/register

The Classifieds 481-3681

**Classified
Deadline
5 p.m.
Tuesday**

Becker Roofing
Farwell (806) 470-7080

**Roofing & New Construction
Custom Cabinetry
Kitchens & Bath Remodeling**

Koehn Builders
New Construction and Remodeling

Cyrus Koehn 480 CR 1
(806) 825-2150 Lic. # 39533 Farwell, TX 79325



See your Valley dealer for advice on the best way to get your machine working to meet your growing demands. He can help you decide the best alternative:

- Fix it with genuine Valley parts
- Upgrade it with Valley major components
- Replace it with a new 7000 or 8000 series machine

Seasonal Cash Allowances available for a limited time.

Farmer's Corner

Things happen to me so that what happens in me will make me the kind of person through whom God can effectively work.

Irrigation Choices from Valley, keep your operation running.

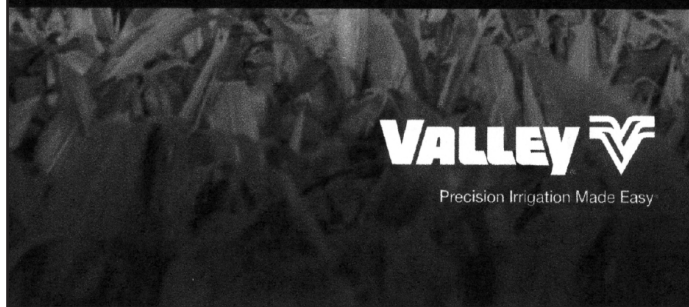

VALLEY
Precision Irrigation Made Easy

FRANSE IRRIGATION INC.

Office: 806-481-3316
Fax: 806-481-3307
E-mail: franirr@plateautel.net

Ralph, Steve, or Jim Franse
711 FM 292, Box 99
Farwell, Texas 79325

JBSudderth Realty, Inc.

Peggy Sudderth Broker
Daren Sudderth Broker Associate & Certified Appraiser

109 5th Street, Farwell, Texas
(806) 481-3288 • (575) 799-4947
Licensed in Texas & New Mexico

www.jbsudderthrealty.com
SOLD

3 Bedroom, 1 3/4 bath brick home. Great starter.
Just Listed - 3 bedroom, 2 bath home on .3 acres just east of Farwell. Has large master bedroom & bath, and is on city water.

Just listed - 2 bedroom, 1 1/2 bath home in Farwell. Single car garage. Priced to sell!

Just Listed - East of Lariat, approx. 545 acres with 4 circles, 5 wells, nice home. Good water area.
SOLD

PRICE REDUCED: Beautifully remodeled country cottage home in Farwell: 4 bedrooms, 3 bathrooms, garden tub in master bath, extra large den with fireplace, central heat, ref. air, large fenced backyard with 2 large storage bldgs. MUST SEE this large home!

3 bedroom, 2 bath brick home in Farwell. Remodeled kitchen & bathroom, large fenced yard. Great location.

160 acres West of Lazbuddie with small house. 2 wells and circle sprinkler.
In Contact

Just Listed - 121.8 acres just north of Muleshoe city limits. \$469/acre.

Northeast of Lazbuddie, 640 acres, irrigated, 4 circles, 9 wells, 2 large steel barns, good farm.

Northeast of Lazbuddie, 318 acres, 2 circle sprinklers, 4 irrigation wells.

Southwest of Texico, 40 acres on paved road. Will split into 10 acre tracts. Call for details!

Just Listed - 160 acres northeast of Bovina. 2 wells, new circle sprinkler. Good farm.

640 acres, irrigated east of Hub, 3 circle sprinklers, 4 wells.

West of Lazbuddie, 800 acres irrigated with 6 circles and large beautiful brick home.

160 acres south of Bovina feeders, 2 wells and 1 pivot.
In Contact

320 irrigated acres east of Hub. 2 circles, 3 wells.

480 acres irrigated. Southeast of Cooks truck stop. 3 circles, 5 wells.

1685 +/- acres irr. near Lazbuddie. 10 circles, 11 wells, on highway.

PORTALES - 20 acre calf ranch, 1 irr. well, county water, 2 bedroom-1 bath home on pavement.

320 acres irrigated NE of Oklahoma Lane, 4 wells, 2 circle sprinklers, nice farm.

Large brick home on 5 acres with bath and improvements.
In Contact

1,585 acres irrigated north of Farwell, 8 circles, 9 wells, large brick home with livestock pens & "hands" house.

120 acres, dryland, north of Pleasant Hill.

160 acres South of Lariat on highway. 1 sprinkler, 3 irr. wells. Owner says sell.

Bovina Area Listings
PRICE REDUCED - 3 bedroom, 2 bath, brick home, large 1 car garage, ready to move into with near new appliances and floor coverings. Great location with beautiful back yard.

Drastically reduced - In Bovina, 2 bedroom, 1 bath home. Completely remodeled inside and out.
"SAVING IS GREAT - INVEST IN REAL ESTATE"

**Senior Citizen
Apartment Available**
Located next to Farwell Convalescent Center.
If interested, contact Gary at 481-9027.

Experienced fulltime tractor operator & farm hand needed. Only those highly skilled in crop cultivation need apply. Minimum 5 years experience. RTK experience preferred. Must speak and read English. References required. Call (806) 272-5901 and leave message.

**Master Tech
Auto Service**
801 Hereford Ave.
Texico -- 482-9087
Jerry Cunningham
Gerryl Roach

**A Brighter Image
Full Painting Service**
Indoor & Outside
Remodeling Work
Decorative Painting
Jack Gilliam
481-2222
Cell: (806) 206-1714
(866) 204-5703
Licensed Contractor

Friesen Lawn Service
Professional
Lawn Maintenance
FREE ESTIMATES
Jay Friesen
(877) 925-6789 • (575) 309-8986
License # LI0017337

**The New You
Beauty Salon**
Lyndi Austin
316 Main, Clovis
763-1360

**Buy, Sell & Trade
New & Used Guns**
Call Brandon
760-0804

RE/MAX

RE/MAX First Place Realtors
817 Llano Estacado Blvd., Clovis
Office: (575) 763-3729
Cell: (575) 693-9545
Toll Free: (800) 345-4166
E-mail: sharonhicks@remax.net
www.SharonHicks.com **Sharon Hicks**
New Mexico/Texas Broker



NEW LISTING 701 4th Farwell -- Over 2000 sq. ft. 2 extra large bedrooms, 3 baths on corner lot. Great brick home with lots of extra storage and built-ins. Unique 1 of a kind floor plan. Priced to sell quickly at \$130,000. Appointment only. Virtual tour www.ihomesource.com.

Vic Coker Land Co.
AGRICULTURAL REAL ESTATE

PARMER COUNTY
Lazbuddie area - 108 acres. 2 wells. Center pivot. Good soils. Lays good.

BAILEY COUNTY
354 acres of expired CRP - Good grass cover. Good improved pasture or return to dryland production.
Near Muleshoe - 90 acre grass seed farm - 2 center pivots. Popular varieties of Foundation Seed.

LAMB COUNTY
North of Earth - 320 acres on pavement, 2 sprinklers, 6 wells, good direct payment.
Northwest of Earth - 160 acres. Excellent soil. Lays good. 3 wells. Center pivot. Good set of pens.
New Listing - Springlake area - 320 acres, good soil, 4 wells, 2 sprinklers, good direct payment.
320 acres near Earth - 2 sprinklers. 5 wells all tied together. Lays perfect. Excellent soil. Good fertility.

RURAL RESIDENTIAL
Lamb County - Springlake area - 2,650 sq. ft. on approx. 4 acres. Brick, 3 bedroom, 2 bath. Good cellar. 30' x 70' barn. Lots of trees.

VIC COKER
Office 272-3100 316 Main St., Muleshoe www.vicoland.com Home 965-2468

SILVERHAWK SECURITY has positions open for Security Guards. Must be 18, have Diploma or GED, with no criminal record. Pays \$8 an hour.
Call (806) 295 - 8357 or come by the security office at Cargill Meat Solutions in Friona, Texas.

West Texas Gas has opening for service technician for Farwell's distribution system. Office work and computer skills along with outside work required. Must be able to pass drug screen. Apply at West Tax Gas office, 100 9th St., Farwell. EOE.

**RECEPTIONIST
POSITION AVAILABLE
FULL TIME**

Experience preferred. Computer skills required.

- Groups health, life, dental, vision & more
- Retirement package
- Paid vacation, sick & holidays
- New facility opening soon

Apply at
Parmer Medical Center
Human Resources
1307 Cleveland
Friona, TX 79035

**Roofing & New Construction
Custom Cabinetry
Kitchens & Bath Remodeling**

Koehn Builders
New Construction and Remodeling

Cyrus Koehn 480 CR 1
(806) 825-2150 Lic. # 39533 Farwell, TX 79325

Byrd Realty

Ronald Byrd
Licensed Broker
Farwell, Texas

Crista Bass
Sales Associate

Office: (806) 481-3846
Toll Free: 1-888-999-3846
308 Third St., Farwell

www.byrdrealestate.net
Sold

JUST LISTED - Very nice 3 bedroom, 1 3/4 bath, with 2 car garage, radiant heat, ref A/C, fireplace, fenced back yard, storage building, many extras. Call for details. Approx. 2,600 sq. ft. in Farwell.

Just Listed 656 acres CRP, 2 years remaining, in Bailey Co.

*450 Acres south of Texico. 14 tower Zimmatic sprinkler. 130 acres grass, 4 submersible wells. Highway frontage on 2 sides.

Spacious 3 bedroom, 2 3/4 bath, brick home, central air, radiant heat, 2 living areas, large utility, lots of closet & storage space, large fenced back yard, 2 car garage, great location.

COMMERCIAL - PRICE DRASTICALLY REDUCED
In Farwell -- Bullfrog Rock & Garden landscaping business for sale. Complete with all inventory & fixtures. 40'x75' metal building. 385' of highway frontage. Completely fenced. Call for details.

WE NEED FARM LISTINGS!!
* -- In Cooperation with New Mexico broker



Devault, Johnson pace Junior High girls' wins

Varsity Boys
The Steers took 4th place in the Littlefield Tournament with a 58-57 win over Shallowater.

The Steers are now 11-6 on the season.

Scoring were Mason Coburn, Lincoln Devault and Octavio Chavez, 8 each; Landry Actkinson, 10 (with a trio of 3-pointers); Matt Billingsley, 1; Rane Carpenter, 7; and Luke Carpenter, 5.

The Steers also tipped Post, 51-50, in overtime.

Scoring were Chavez, 15; Actkinson, 11; Billingsley and Rane Carpenter, 8 each; Coburn, 5; Devault, 2; Collin Christian and Luke Carpenter, 1 each.

Varsity Girls

The Lady Blue are 15-3 after taking 4th place in the Littlefield Tournament with a 48-32 win over Littlefield.

Scoring were Keegan Langford, 18; Laney Christian, 2; Kristin Langford, 6; Laura Martinez, 9, and Tiffani Jones, 13.

The Lady Blue also knocked off Snyder, 70-45.

Scoring were Caitlyn Stancell, 2; Keegan Langford, 12; Kristin Langford, 2; Martinez, 12; Jones, 31 (including five

3-pointers); Lauren Meyer, 9, and Keila Jennings, 2.

7th Girls

Farwell's 7th grade girls put away Olton, 28-20.

Scoring were Kianna Barrera, 4; Cassidy Devault, 10; Taylor Presnell, 5; Emily Stancell, 9.

8th Girls

Farwell's 8th grade girls tipped Olton, 33-32.

Scoring were Lauren Carpenter, 6; K'Leigh Jo White, 7; Jill Johnson, 13; Kelsey Knight, 4; Taylor Stancell, 3.

JV Girls

Farwell's JV Girls killed Dora, 47-10.

Scoring were Abby Johnson, Chandler Barnes and Sasha Lara, 6 each; Kayla Cullison and Madison Rudd, 2 each; Chelsea Bass, 4; Clara Reyes, 7; Brooke Williams, 5; Clarisa Garcia, 9.

JV Boys

Farwell's JV Boys beat Dora, 48-35.

Scoring were Luis Galvan, 8; Tyler Schilling, 2; Ray White, 9; Kolten Morris, 6; Zac Stancell, 5; Colby Read, 4; Edgar Cuevas, 14.

Lazbuddie Junior High Girls Tournament

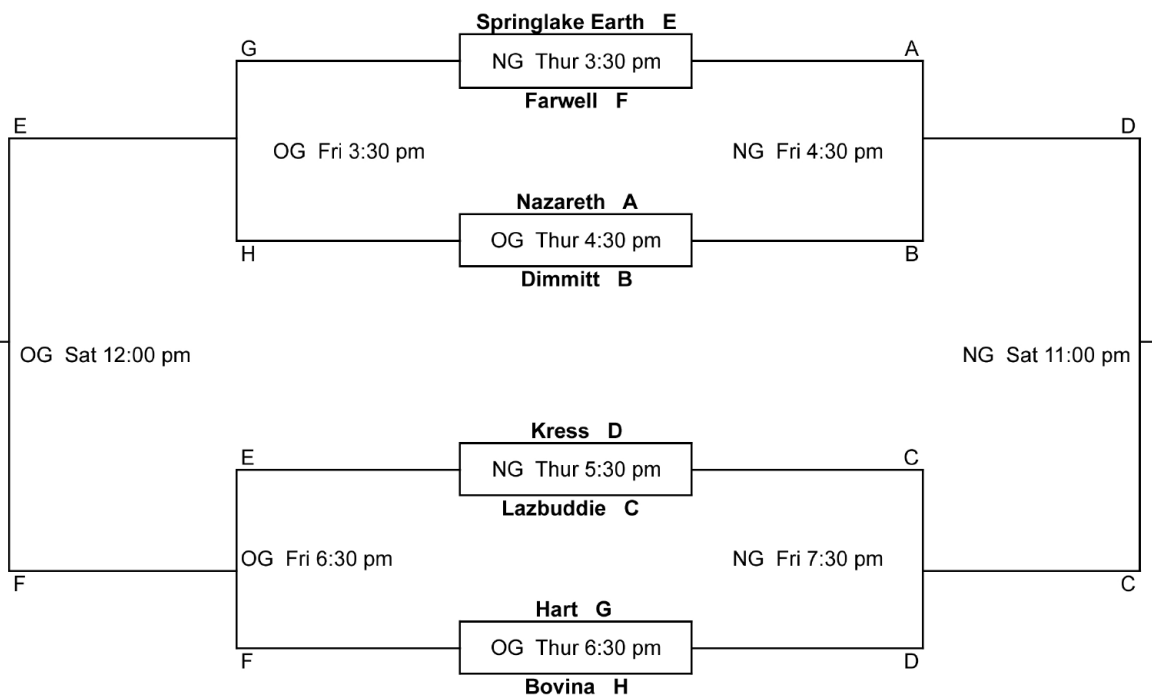

Lazbuddie Junior High Boys Tournament

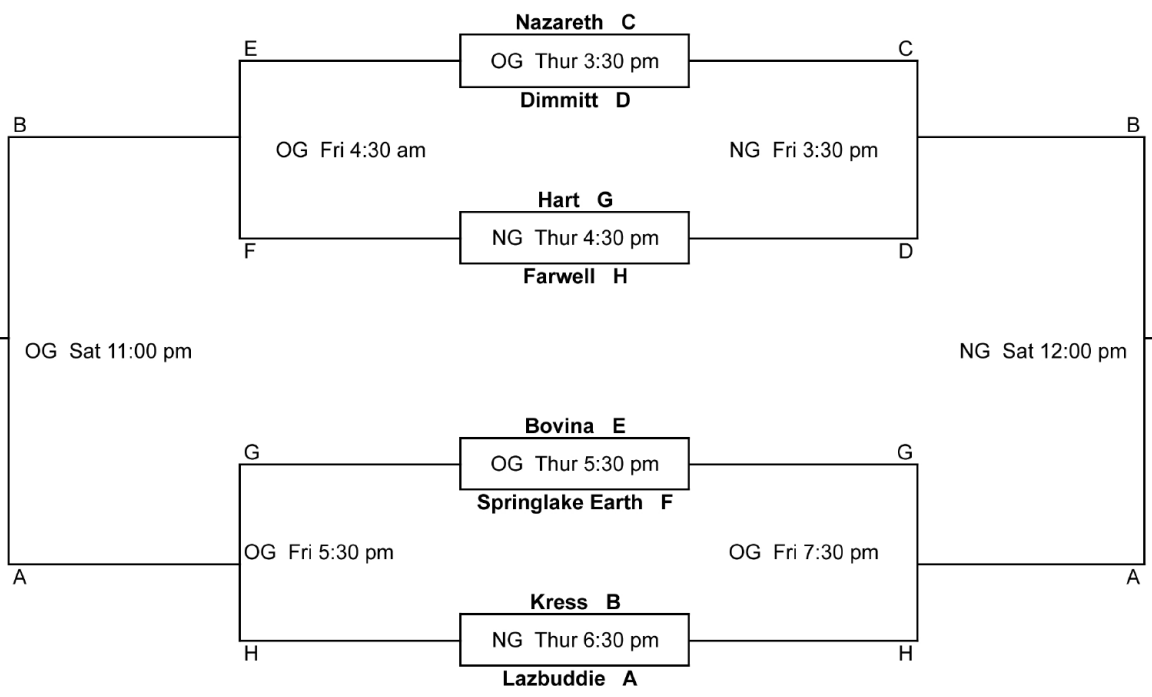

The Pharmacy That's All About Your Health

1801 W. 21st St. Clovis, NM 762-4579
Half-mile east of Plains Regional Medical Center Hospital
Jim Herman -- Pharmacist
Debra Herman -- Pharmacist



Sheri Tharp
Owner/ Operator

111 First Street
Farwell, TX 79325
(575) 309-7597

9 to 5:30 Monday, Tuesday, Thursday, & Friday
Walk-ins Only

Bring Back the Obelisk

Please contribute to having Farwell's famed landmark be replicated.

Send your check to: Farwell Obelisk Fund, in care of Security State Bank, Drawer J, Farwell TX 79325.

Be part of bringing back some of Farwell's proud history.



Was your baby the **LAST** baby born in 2009?

If you live in Muleshoe, Sudan, Earth, Lazbuddie, Farwell or Morton, and your baby was the last baby born in 2009

H&R Block has gift for you!

H&R BLOCK Call Kay Wiseman at 272-3332

Texico
Monday - nachos with meat & cheese sauce, pinto beans, fruit, milk.
Tuesday - chalupas with cheese, LT, corn, fruit, milk.
Wednesday - spaghetti with meat sauce, green beans, hot rolls, fruit, milk.
Thursday - chicken patty on bun, French fries, LP, fruit, milk.
Friday - sloppy joe on bun, ranch style beans, pickle spear, fruit, milk.

Farwell
Monday - BBQ sandwich, baked beans, pickle spears, mixed fruit, Rice Krispy, milk.
Tuesday - spaghetti, green beans, Italian rolls, peaches, milk.
Wednesday - glazed chicken, rice veggies, Texas toast, pineapple, milk.
Thursday - chalupas, LT, corn, fruit Jello, milk.
Friday - cheese sticks with sauce, garden salad, ranch dip, orange slices, cookies, milk.

MENUS
Citizens Bank
Texico Branch



We're Proud Of The Young People Of Parmer County!

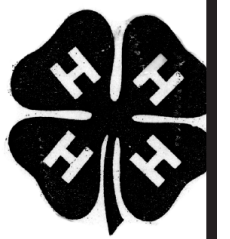

Welcome to the **62nd Annual Parmer County Junior Livestock Show** January 13-16
Frona Community Center

West Texas Rural Telephone Cooperative

P.O. Box 1737 • South Hwy 385
(806) 364-3331
Hereford, Texas 79045

COMPOSTED CATTLE MANURE

Farwell Feed Yard -- Farwell
Cargill Cattle Feeders -- Bovina
Bovina Feeders -- Lazbuddie

BRANDON SCHILLING

Mobile 806-225-7700
OFFICE 1-800-650-2550

NORTH PLAINS COMPOST, INC.

PO BOX 1099
FARWELL, TEXAS 79325

Farwell Convalescent Center has Christmas celebration



Farwell Convalescent Center Auxiliary member Liz Kaltwasser serves refreshments.



Farwell Convalescent Center residents and family members enjoy the annual Christmas party. The FCC thanked Cargill Meat Solutions, the FCC Auxiliary and all others who helped with the party and the Angel Tree project.



Jesse Gonzales had a large amount of family members visit during the Christmas party.

The Latest

The EPAC Basketball Tourny began on Jan. 5. Here's a look at Texico schedules:

Boys – The No. 1 seed Wolverines open on Jan. 6 at 8 p.m. mt at Melrose

against the winner of the Melrose-San Jon game. If Texico wins, they play again at 5:30 p.m. mt on Jan. 8 at ENMU. The title game is on Jan. 9 at 8:30 p.m. mt at ENMU.

Girls – The No. 1 seed Lady Wolverines open at Melrose on Jan. 6 at 8 p.m. mt against the winner of the Melrose-Tatum game. If Texico wins, they play again on Jan. 8 at 4 p.m. mt at ENMU. The title game is on Jan.

9 at 7 p.m. mt at ENMU. *** Gerald and Karan Stout have a new grandson, Carter Lance Swann.

*** Farwell High graduate Tate Nichols has gradu-

ated from Texas Christian University with a bachelor's degree in business administration (finance and marketing).

The son of Tom and Terri Nichols, of Farwell, hopes to stay in the Dallas area.



Ricky Stewart with his mom, Betty.

Plateau's Safety & Security Plan

USF Offering **ONLY \$19⁹⁵!**

The Plateau Safety & Security Plan includes:

- 100 Local Anytime Minutes
- FREE Nationwide Long Distance
- Caller ID & Detailed Billing
- Carryover Minutes

Plateau is proud to participate in the USF Lifeline and Link Up programs. These programs assist eligible consumers to establish and maintain telephone service. For information on eligibility, please go to www.plateautel.com/usf_offering.asp or visit any Plateau store for details.

www.plateauwireless.com
877-PLATEAU (752-8328)

PLATEAU
Wireless

Clovis
Plateau Superstore
2701 N. Prince
(575) 935-CELL
(575) 935-2355

Farwell, TX
ENMRPlateau
200 Ave. A
(806) 481-3800

Frona, TX
WT Services
1010 Columbia
(806) 250-5555

Muleshoe, TX
Five Area Telephone
Coop.
302 Uvalde
(806) 272-7700

Contract Term: One (1) year. Activation Fee: \$25. Early termination fees: \$100 per year, maximum of \$200 and is prorated. A flat rate of \$0.50 per minute (includes Roaming and Long Distance) will apply when outside the rate plan's designated home area. Overage rate is \$0.50 per minute. Free Nationwide Long Distance is only available from the Local Plateau Calling Area. Additional taxes, fees, and surcharges may apply. This service includes voice grade access to the public switched network, tone dialing, access to interexchange service, access to operator services and directory assistance, telecommunications relay service, and 911 emergency service. Offer not available in all markets.

GOOD LUCK To Each Participant In The Annual Stock Show

Let's all get out and enjoy the 62nd Annual Parmer County Junior Livestock Show Jan. 13-16 in Friona!



BAILEY COUNTY ELECTRIC COOPERATIVE ASSOCIATION

272-4504 -- Muleshoe



No matter what you show, we are proud of the hard work you put in!

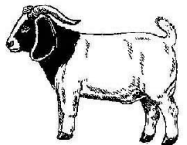

Best of luck at the 62nd annual Parmer County Stock Show, Jan. 13th-16th in Friona.



Come on out and support these hard working kids learning about farming and ranching in our area!

ichooseCommunity



Join our Meat Solutions Team

Cargill, Inc
Frona TX

Cargill Cattle Feeders
Bovina TX

Apply at Department of Labor in Clovis, NM or call 575-762-4571 or 806-295-8227



Deaf Smith Electric Cooperative Annual Meeting Tuesday March 24, 2009

HATS OFF...

To all 4-H and FFA Members Who Are Participating In The

62nd Annual

PARMER COUNTY STOCK SHOW

January 13-16



Hey, kids, have a safe and fun stock show. And always remember to use extreme caution when you're around electric lines. Good luck at the show!

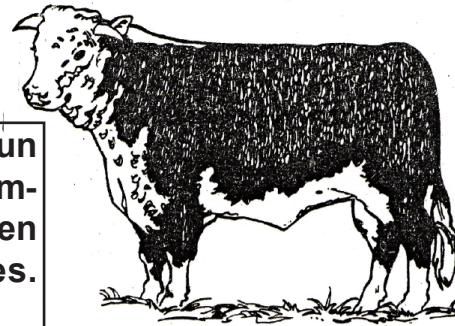

Deaf Smith Electric Cooperative

Your Touchstone Energy® Cooperative
The power of human connections



Here's a look at past Parmer County Stock Show champions

Here's a look at the Parmer County junior livestock show champions over the years:

In some years, there were no "grand champions" in the lambs category so the breed champions are listed.

1948 - Maurice Gaede, steers; Clyde Hays, barrows.

1949 - Weldon Massey, steers; Roy Miller, barrows.

1950 - Herbert Schueler, steers; Frankie Allen, barrows.

1951 - Don Jesko, steers; Friona FFA, barrows.

1952 - Ben Jordan, steers; Bob Geries, barrows.

1953 - Mary Tatum, steers; Truman McKillip, barrows.

1954 - Jerry Henson, steers; Gerald Hardage, lambs; Jerry Gleason, barrows.

1955 - Frank Spring, steers; Jackie Sheek, lambs; Don Bandy, barrows.

1956 - Leon Massey, steers; Jackie Sheek, lambs; Don Bandy, barrows.

1957 - Glen Watkins, steers; Kent Glasscock, barrows.

1958 - Jim Wells, steers; Jim Greeson, lambs; Calvin Mason, barrows.

1959 - Darrell Jennings, steers; Pat O'brian, lambs; Dickie Geries, barrows.

1960 - Bobby Redwine, steers; James Brown and Pat O'Brian, lambs; E.C. Wilson, barrows.

1961 - Craig Coon, steers; David Koelzer, Terry Parham and Jim Roy Wells, lambs; Jimmie Dale Seaton, barrows.

1962 - Risa Howell, steers; Steve Young, John Ward and Steve Foster, lambs; Theresa Seaton, barrows.

1963 - Dwain Phipps, steers; Mariana Gammon, Dwain Phipps and Darrell Mason, lambs; Bobby Gleason, barrows.

1964 - Rex Wells, steers; Mariana Gammon, Terry Parham and Darrell Mason, lambs; Theresa Seaton, barrows.

1965 - Mike Riethmayer, steers; Terry Parham, Royce Barnes and Jerry Roach, lambs; Bobby Gleason, barrows.

1966 - Gary Phipps, steers; David Nelson, Daryl Kirkpatrick and Royce Barnes, lambs; Rick Seaton, barrows.

1967 - Jacquelyn Langford, steers; David Nelson, Wesley Barnes Jr. and Carrol Foster, lambs; Rick Seaton, barrows.

1968 - Mark Haseloff, steers; Monte Barnes and Pablo Mendoza, lambs; Rick Seaton, barrows.

1969 - Robert Haseloff, steers; Randy Waggoner, Jesse Mendoza, Charles Bentley and Stephen Sherrill, lambs; Stan Treider, barrows.

1970 - Gail Morris, steers; Pablo Mendoza, Mark Barnes, Karene Hart and Mike Windham, lambs; Randy Bush barrows.

1971 - Carrie Haseloff, steers; Jesse Mendoza, Larry Johnson, Mark Barnes, Hugh Rogers and Mike Windham, lambs; Rick Seaton, barrows.

1972 - Mark Haseloff, steers; Jesse Mendoza, Tim Smith, Neal Moore and Mike Windham, lambs; David Gallman, barrows.

1973 - Annette Langford, steers; Mike Windham, Tim Smith, Dennis Willard, Karene Hart and Kevin McClaran, lambs; Rick Seaton, barrows.

1974 - Jacquelyn Langford, steers; Mike Windham, Tim Smith, Duane Mitchell, Dennis Johns and Russell Windham, lambs; Charleson Steinbock, barrows.

1975 - Mac Langford, steers; Mike Windham, Tim Smith, Mark Foster, and Russell Windham, lambs; Mark Mimms, barrows.

1976 - Joan Carson, steers; William Martin, Donny Gustin, Sean Mason, Lezli Williams and Mark Clayton, lambs; Mike Windham, barrows.

1977 - David Lust, steers; Randy Smith, lambs;

Brent Green, barrows.

1978 - Joan Carson, steers; Tim Garner, lambs; Joe Reeve, barrows.

1979 - Dean Church, steers; Charlie Trimble, lambs; Russell Windham, barrows.

1980 - Phillip Jesko, steers; Sean Mason, lambs; Vandi Tarter, barrows.

1981 - Roddy Berend, steers; Casey Riddle, lambs; Joe Dan Tarter, barrows.

1982 - Jeff Lundy, steers; Bret Whitten, lambs; Danna Ralston, barrows; Corrie Lundy, heifers.

1983 - Corrie Lundy, steers; Terry Moore, lambs; Beth Johnson, barrows; Roddy Berend, heifers.

1984 - Dana Berend, steers; Terry Moore, lambs; Susan Redwine, barrows; Carl Hutchins, heifers; Greg Salyer, goats.

1985 - Dana Berend, steers; Tracy Moore, lambs; Chad Rhodes, barrows; Dana Berend, heifer; Shannon Cochran, goats.

1986 - Dana Berend, steers; Donell Garner, lambs; Vandi Tarter, barrows; Dana Berend, heifers; Blake Kelley, goats; Mendy Rhodes, turkeys.

1987 - Michael Head, steers; Jennifer Smith, lambs; Clint Hurst, barrows; Michael Head, heifers.

1988 - Michael Head, steers; Guy Ellis, lambs; Clint Hurst, barrows; Michael Head, heifers.

1989 - Rusty Simmons, steers; Jessica Smith, lambs; Susan Redwine, barrows; Brett Thomas, heifers.

1990 - Rusty Simmons, steers; Cade Morris, lambs; Cammy Hancock, barrows; Shannon Cochran, heifers.

1991 - Clay Hurst, steers; Shana Foster, lambs; Casey Bradshaw, barrows; Amy Hartzog, heifers.

1992 - Lori Bradshaw, steers; Monty Schueler, lambs; Shane Roberts, barrows; Jarah Redwine, heifers.

1993 - Clay Hurst, steers; Monty Schueler, lambs; Dawn Weir, barrows; Jarah Redwine, heifers.

1994 - Jason Jesko, steers; Kevin Schueler, lambs; Kia Morris, barrows; Rusty Simmons, heifers.

1995 - Jill Hodges, steers; Cade Morris, lambs; Jessica Smith, barrows; Rusty Simmons, heifers.

1996 - Brice Redwine, steers; Staci Foster, lambs; Wade Schueler, barrows; Alicia Smith, heifers; Kolby Wilkerson, goats.

1997 - Jeffery Seaton, steers; Shana Foster, lambs; Clint Patterson, barrows; Alicia Smith, heifers.

1998 - M'Kell Jarecki, lambs; Alicia Smith, steers; J'Lond Jarecki, barrows; Candace Davis, goats; Tray Thorn, heifers.

1999 - Landon Parham, steers; Triston Thorn, heifers; Jeremy Campbell, barrows; Candace Davis, goats; Cade Morris, lambs.

2000 - Landon Parham, steers; Cassie London, lambs; Devin Goettsch, goats; D'Anna DeLeon, barrows.

2001 - Suzanne Mason, lambs; Josh Kerby, barrows; Kolby Wilkerson, goats; Landon Parham, steers.

2002 - D'Anna DeLeon, barrows; Lakota Goe, goats; Dalton Cockerham, steers; Kelby Monroe, lambs.

2003 - Matt Billingsley, goats; Keith Hunt, lambs; Brittany Berend, steers; Kayla Parham, barrows.

2004 - Jason Berend, steers; Kolten Morris, lambs; Ryan Mason, goats; Jennifer DeLeon, barrows.

2005 -- Austin Mason, lambs; Danielle Cockerham, barrows; Ryan Mason, goats; Brittany Berend, steers.

2006 -- Jennifer DeLeon, barrows grand champion; Lincoln Devault, barrows reserve champion; Jason Berend, steers grand champion; Hayden Hadley, steers reserve champion; Logan Mason, lambs grand champion; Kelby Monroe, lambs reserve champion; Ryan Mason, goats grand champion; Ashton Mason, goats reserve champion.

2007 -- Steers: Brittany Berend, grand champion; Drew Johnson, reserve grand champion; Dairy heifers: Zac Stancell, grand champion; Bretton Stancell, reserve grand champion; Goats: Ashton Mason, grand champion; Ryan Mason, reserve grand champion; Lambs: Kolten Morris, grand champion; Jordan Monroe, reserve grand champion; Barrows: Ashton Mason, grand champion; Ryan DeLeon, reserve grand champion.

2008 -- Barrows: Ryan DeLeon, Grand Champion and Reserve Champion; Steers: Brittany Berend, Grand Champion, and Drew Johnson, Reserve Champion; Goats: Tyler Hough, Grand Champion and Reserve Champion; Lambs: Chase Timms, Grand Champion, and Kolten Morris, Reserve Champion; Heifers: Chase Timms, Grand Champion, and Kayle Jesko, Reserve Champion.

2009 -- Barrows: Logan Mason, Grand Champion, and Abby Johnson, Reserve Champion; Goats: Logan Mason, Grand Champion, and Ashton Mason, Reserve Champion; Lambs: Logan Mason, Grand Champion, and Hannah Carthel, Reserve Champion; Steers: Drew Johnson, Grand Champion, and Abby Johnson, Reserve Champion; Heifers: Zac Stancell, Grand Champion, and Ray White, Reserve Champion.

POOL LAW FIRM, P.C.

Bankruptcy (Chapter 7 & 13)
Adoption * Child Support * Criminal
Wills * Probate * Guardianship
Divorce * Other Legal Matters

Wesley Pool, attorney
Mickie Patterson, attorney
(806) 272-8900
312 W. 2nd St., Muleshoe, TX



Email: wesley@poollawfirm.com

Not certified by Texas Board of Legal Specialization

BENDER CHRYSLER • DODGE

Where the Dealin' is Easy!

Buying a USED car shouldn't
be like pulling teeth



We make car buying
easy and painless!

Come see for yourself!
You'll be glad you did.

Stop in & talk to one of our
experienced sales associates TODAY!

3400 Mabry Drive, Clovis NM 88101

575-762-4511 • 1-800-466-4513

www.benderdodge.com



WE ARE YOUR HOMETOWN
WHIRLPOOL DEALER.

McDaniel's
APPLIANCE

1020 Main Street, Clovis, NM • 575-762-4481 or 800-682-7891

FREE Delivery,
Haul Away,
& Power Cord

Clip & Bring in for a
\$30.00
DISCOUNT
Valid until 1-31-10 Any Appliance Over \$349.00

Whirlpool Speed Queen LG
Frigidaire KitchenAid
See Our Ad In
Names and Numbers
***** Five Star Phone Books!
Appliances in stock available for immediate purchase

STEED-TODD

Funeral Home

"When Understanding Is Needed Most"

Prince & Manana -- Clovis
Phone 763-5541



THE BONE JOINT CHIROPRACTIC CLINIC

Dr. Mindy R. Neal

Office: 806-251-1300
509 Avenue I • Bovina, TX 79009
www.drmindy.com

GOOD LUCK!

To all the
area youth
who will be
participating
at the
Parmer County
Junior Livestock
Show



January 13-16



First
National
Bank
Friona Banking Center
714 W 11th • 806-250-2900
Monday-Friday 8:30 A.M. - 4 P.M.

Member FDIC

The Latest

Lincoln Riley, 26, of Muleshoe, coached the offense for Texas Tech in its Bowl game last week-end.

Sales have begun for the Parmer County History Book, 3rd edition.

Pre-published price is \$45 with \$3.50 postage if the book must be mailed. Payment must be received before Feb. 1; afterward, they cost \$50. Books are expected in by early February.

Books can be ordered from Sharon White at 265-3874, Bonnie Howard at 481-9023, or Gladys Spring at 251-1552.

Gift cards are available. Be sure to request a gift card should one or more be needed.

Bruce Billingsley has retired as the Farwell service technician for West Texas Gas. He plans to continue living in Farwell.

Granite and Solid Surface Countertops
ALLIED
300 Hwy. 86
Bovina, TX. 79009
A local company,
A professional installation,
Let us help you with your
kitchen and bathroom countertops today!
"It all begins with a good template"
Josue Gonzales (806) 206-4025
Jorge Mascareno (505) 206-6172

High Plains Sleep Disorders Center
Where you'll find a Friendly,
Home Environment for Sleep Studies,
CPAP Therapy Machines & Supplies.
2001 W. 21st Street
Clovis, NM 88101
Office: 575-763-4725
Fax: 575-763-4743

Bovina Banter

Deanna Curtis • 251-1405

The JV and varsity girls play at Springlake-Earth on Jan. 8. The JV and varsity boys host Anton on Jan. 8. The varsity and JV teams host Morton on Jan. 12. The Middle School teams play Morton on Jan. 11 – girls there and boys here. The MS teams also play in the Lazbuddie Tournament this weekend.

The JV teams originally were scheduled for the Lazbuddie tournament but were "fill-ins". They still may be needed if Nazareth backs out. As of press time, the JV teams were not scheduled.

The city is having a couple of its employees work on a monthly newsletter to be printed in Spanish for residents.

Last year, the city purchased four properties at auction, three of which had abandoned structures on it.

So far, two of the buildings have been demolished with one to go.

The city is getting a \$20,000 energy grant from the state.

It will be used to help insulate the fire department building (and this will especially help with the water tankers), and also at City Hall with storm windows and a vestibule for the front door.

As a continuing fund-raiser for the Community Center project, starting this month, the city employees will serve lunches from noon to 1 p.m. on the 2nd Friday of each month at the EMS building.

The cost will be \$7.50 a plate.

City Manager Jana Pitcock said she plans to put up a billboard in front of the EMS building which will

Obituary

Gladys Wright

Service for Gladys Mae Wright, 87, of Muleshoe, were Jan. 4 at Bovina Cemetery with Heath Wright of Albuquerque, and Lee Walker, of Amarillo, officiating.

She died Jan. 2. She was born July 26, 1922 in Maud, Texas. She married J.W. Wright in Burkburnett, Texas, on June 19, 1940. He died in 1999.

She moved from Burkburnett to Bovina in 1954, then to Muleshoe in 2004.

She was a member of

the First Baptist Church of Bovina and was a homemaker.

Surviving are 2 sons, Jerry, of Albuquerque, and Joe, of Lubbock; 2 sisters, Louise Summers, of Thornberry, Texas, and Betty Aday, of Byers, Texas; 5 grandchildren, and 15 great grandchildren.

She was preceded in death by a son, Jimmy, in 1966 and a brother, Gene Varner, in 2009.

Ellis Funeral Home handled the arrangements.

show what is to be served that month.

2010 is here! Now is an opportunity to start anew. What will you do different? There is always room for improvement.

Our School Board will meet on Jan. 11th at 5:30 p.m. at the administration building.

As always, these meetings are public and you are encouraged to attend.

If you ever have an issue, please contact your child's teacher and follow the chain of command. The school, teachers, principals, and administration are here to help provide your child with an exceptional education.

It is also a parents' responsibility to help their child and the school to provide this education. Teamwork is of the most importance.

ESL classed provided by Clovis Community College resume on Jan. 15th.

They are free of charge and are held on Tuesdays and Thursdays at 804 Boyce St.

All you will need for the class is a little determination.

Next week's school lunch menus:

Monday – chicken fried steak, pepperoni pizza, cream potatoes, green beans, tossed salad, rolls, peaches.

Tuesday – chicken & rice, hamburger, tortillas, corn, tossed salad, potato wedges, fruit cocktail.

Wednesday – meat & cheese nachos, pepperoni pizza, pinto beans, tossed salad, yogurt.

Thursday – chicken & noodles, toasted cheese sandwich, hamburger, mixed veggies, tossed salad, cottage cheese, pears.

Friday – sloppy joes, pepperoni pizza, peas, tossed salad, potato chips, cottage cheese, peanut butter cookie, apple sauce.

City Council will meet on Jan. 12th at 7 p.m.

The Bovina Chamber of Commerce met on Jan. 5. If a banquet is going to be held, they will need help. Interest and involvement in the Chamber have dwindled in recent years and is reaching a crucial point.

Unfortunately, there is a strong possibility that the Chamber will need to close down for a while until more volunteers step up.

Time for a new appliance? Let us help!

McDaniel's

APPLIANCES

1020 Main Street, Clovis, NM • 575-762-4481 or 800-682-7891

Whirlpool

Names and Numbers
Five Star Phone Books!
namesandnumbers.com

This is a very sad thing for Bovina. If you have been contemplating joining or volunteering, now is the time to do it.

Contact Dr. Neal, Chamber president, at 251-1300.

The Bone Joint Clinic is open again after being closed for a couple of weeks.

Dr. Mindy Neal is back and doing great after a surgery.

I know many people have told me they will be at her doorstep when she opens for an adjustment.

We are all glad you are doing well, Mindy. So glad to have you back.

Interesting Fact of the Week: An ostrich's eye is bigger than its brain. Do you know anyone like that? Hey ... be nice.

Flores, Rueda pace Fillies past Lubbock Christian

<p>Varsity Girls The Bovina Fillies are 5-7 after beating Lubbock Christian, 49-37, last weekend. Scoring were Jeanette Varela, 2; Kim Casas, 6; Yoselin Rueda, 16; Daniela Flores, 18, and Lynda Rodriguez, 7.</p>	<p>JV Boys The Bovina JV boys lost 54-37. Scoring were Kristian Antillon, 7; Erli Rueda, Stefon Knoll and Justin Curtis, 2 each; Luis Sanchez, 7, and Abel Rocha, 11.</p>
--	--

<p>Varsity Boys The Mustangs lost 81-40. Scoring were Alexis Martinez, 6; David Martinez, 4; Desmond Fox, 3; Andy Duarte, 5; Dorian Vela, 12; Andrew Marrufo, 8, and Matt Knoll, 2.</p>	<p>JV, Varsity The JV and varsity games with Lorenzo were cancelled after Lorenzo's request. Also, there have been few reports on the Bovina JV girls this season since most of their games have been cancelled.</p>
--	---

After-School Specials at Food Express Every Weekday from 4 to 6 p.m.

Personal pan single topping Pizza -- \$2.49
Nacho's -- \$1.59
Hot Dogs – 89¢; Corn Dogs – 59¢
Don't forget that Happy Hour is 3 to 5 p.m. every day:
All fountain drinks & coffee – 92¢

Best of Luck to the 4-H & FHA youngsters who will be exhibiting their animals at the 62nd annual Parmer County Junior Livestock Show January 13-16 in Friona

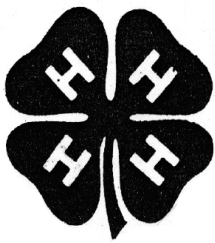

Your hard work was very evident when you displayed your animal projects at The Parmer County Junior Livestock Show!

WT Services Inc.

A Fully Owned Subsidiary Of West Texas Rural Telephone
1010 Columbia at Hwy 60, Friona 250-5555
Hours: 8 a.m. to noon & 1 to 5 p.m. Monday-Friday

The 62nd Annual Parmer County Junior Livestock Show will be held Jan. 13-16 in Friona

We are happy to support the youth of our community.



Thanks for all the entrants who worked so hard for this year's Parmer County Jr. Livestock Show!

Cargill Cattle Feeders

Pat Schwab, Manager
225-4400

BOVINA



Proud Home of the Mustangs & Fillies

It is up to you

Unfortunately, there is some bad news to report this week: the Bovina Chamber of Commerce has a major problem.

For many of the past several years, Mindy Neal has served as Chamber president and done an outstanding job.

This past year, Mrs. Neal also has been heavily involved in the wind farm project to the point where she needs some major help from Chamber members and Bovina citizens if there is to be a Chamber banquet this spring.

If folks don't step forward to help here, there will be no Chamber honors banquet this year. No Man and Woman of the Year. No Students of the Year. No Teacher of the Year. No Pioneer of the Year.

And that would be a major loss to our community because there are many deserving people out there who should be honored for their devotion to our community.

Also, the Chamber faces a lack of funds. If the banquet is to be held, there may not be money available to bring in some entertainment. Perhaps, you know of some performer who would be willing to come for free?

Well, there you have it, folks. Plain and simple.

If there is no help forthcoming, it could spell the end to a vital instrument of Bovina progress.

Mrs. Neal can be contacted at 251-1300.

5th grade band performs



Christmas Concert



Cargill Cattle Feeders
Pat Schwab, Manager
225-4400



Homer A. Haile, Agent
1015 W. 11th, Friona
(800) 925-0624
(806) 250-2734



Sherley - Anderson
907 Hwy. 86 West • 251-2510



Bovina Branch

101 N. 3rd St. • 251-1442

Member FDIC

Equal Housing Lender

1% Check Cashing Fridays
7 a.m. to 4 p.m.
Food Express
Hwy. 60 • 251-9945

Bovina Pump
W. Hwy. 86 • 251-1596

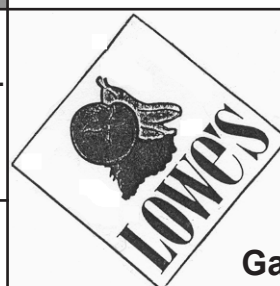

Lowe's Supermarket

Gabriel Medrano, Manager
800 Hwy. 86 • 251-1324