

Wishing You and Yours the Blessings of Christmas

Border Banter

By Mike Pomper

It makes us whole

Ah, Christmas...
What a beautiful time to enjoy.
Sure, life isn't perfect. But it sure beats the alternative.
This is a good time for a silent "thank you" to the fella up above.
One of the things I've tried to teach my children is how to deal with the ups and downs of life. Everyone gets a portion of both.

When things are going well, I've said, remember to thank God for the blessings. When things go badly, remember to do the best you can under those circumstances because we get judged on how we handle the problems that befall us.

As an individual who has had more than his share of ups and downs over the years, I feel that's a good way to view things. It steadies the course you are on.

This is the time of year when I don't think of the downs so much. It's hard when you see all the blessings around you: family, home, a job. As I've written before, we are fortunate human beings.

And what's most important is that we have something special within us. Sure, having a decent place to live is important; same goes for getting a salary. But the knowledge that we have faith in God is vastly more important.

It's been a bunch of years since the manger scene that we see in our churches actually took place. And I'm sure some of my readers are saying "bah, humbug" to that. There's nothing I can write to make them change their minds; it's something they have to change from within.

All I know is that almost 2,000 years ago a child was born who changed the course of history. And it's hard for me to think of anything more important than having faith in him. Having faith in God helps make us whole.

I'm not very smart at religious matters. Any minister or priest could do a heckuva lot better at writing this column than I can.

All I want to say is that it's Christmas. It's a time to thank God for the blessing He gave us in the form of His son. And it's a good time to remember how important it is to be faithful to Him.

My family wishes you the best of Christmases...

We'd like to congratulate Bovina football coach Bill Talley on being named District 1-A Coach of the Year by the Lubbock newspaper.
That's quite an honor.

Trash pickups for Texico residents will be a day early this week and next due to the holidays.

There was a train derailment about four miles east of Texico early Wednesday morning.

A note for readers who have moved away from this area: the proposed nuclear dump site in Deaf Smith County has been abandoned. The U.S. Senate took action to drop funding the alternative.



Mr. and Mrs. Jack Williams

50th anniversary celebrated

Mr. and Mrs. Jack Williams of Farwell celebrated their 50th wedding anniversary on Dec. 24 with a family reunion at Ruidoso, N.M.

Jack and Ella Ruth Williams were married on Christmas Eve, 1937, in Clinton, Okla.

Attending the reunion were Dick and Marie Williams and their children, Karen, Brian, and Janna from Houston; Tom

and Janice Williams and their children, Scott and Laura from Fort Smith, Ark.; and Sharon and Israel Armendariz and their children, Anthony, Monica, and Matthew from Lubbock.

Unable to attend were Bert and Wanda Williams and their children Sheryl and Susan who are currently in London, England.

A new Christmas perspective

(Editor's note: The following stories were written by the Communications Skills classes at Texico High School. The students were asked to write about Christmas from an unusual perspective.)

My Scary Christmas
Melissa Freeman

It was five days before Christmas. There were only two presents under our tree. I was beginning to wonder if they were going to be joined by any more. I thought maybe times were getting tough, because there were few presents and hardly anything to eat. There weren't even very many crumbs. Usually we had all kinds of things to eat, but I just ate what I could find and didn't worry.

It was finally Christmas morning. It was the first Christmas I didn't want to get up. Last night when I woke up, I looked and there still were only two presents under the tree. I wasn't even really sure that Santa Claus was going to bring any presents for me, because I had been a bad girl earlier in the year.

Somehow I managed to get out of bed and go to our living room. That's when I saw all the presents and my family singing and laughing. I was so happy. We all got everything we ever wanted.

After I had played with my toys for a while, I got hungry. I peeked out our mouse hole and saw all the food I could ever eat.

The Funny Christmas
Tony McIntosh

Tinke is my name and making trains is my game. I am one of Santa's elves. I'd like to tell you a story about Santa's funniest Christmas.

I believe it was back in 1974 on Christmas Eve. We had just received word that Santa was at his last stop.

He had just stopped in a parking lot, when the local TV news crew caught him on the spot. They asked him some questions like: "How much money has the Salvation Army raised?" and "Why don't you have a bell to ring?"

Santa said: "I don't know, but I must go."

The news crew let him pass, and he jumped into his sleigh and began to fly. The news crew could not believe their eyes as

Santa left he exclaimed, "On Dasher, on Dancer, on Prancer and Vixen, on Comet, on Cupid, on Donner and Blitzen. Now dash away, dash away, dash away all. Merry Christmas to all, and to all a good night."

Turn Me On
Luis Ortiz

I have a very important job. I am an electric circuit in your home. It was Christmas Eve, and all the lights in the house were on, including those on the tree and the decorations outside. I was having a tough time keeping everything going. Some of the outlets were using so much electricity that they were getting ready to overload.

Suddenly, I blew a fuse and the lights went off. Then the fuse was replaced and some lights turned off. Later I discovered there was a problem with the Christmas tree. The wires were bare and touching the carpet. During the night all the lights were off and the people were asleep. Only the Christmas tree lights were on, and the bare wires were still on the carpet. I was sure it would start a fire before morning. Then something shook my roof wires!

Suddenly I saw a man with a big white beard and a red suit. I could not believe my eyes. It was Santa Claus. He first put a lot of presents under the tree. As he was leaving, he saw the wires. Immediately he reached into his pocket and pulled out some electrical tape and repaired the wire. As he left he said, "I wish everyone has a safe and happy Christmas."

Fuzzy Blue
Todd Cash

Oh boy! It's finally Christmas morning. Some little boy will open my package, and hopefully I will watch his eyes light up with joy.

Will he like my plush blue ears and my fuzzy white tail? Will he like my brown eyes and my soft paws? Will he hold me and squeeze me and play with me a lot?

When he plays with me, will he be mean and rough, or will he play gently and softly, and will he take good care of me? Will he give me lots of attention and love. When I'm old and torn and raggedy, will he stop playing with

(Continued on Page 5)

FARWELL, TEXAS

DEC. 25, 1987

32 PAGES

THE STATE LINE

TRIBUNE

"OFFICIAL PUBLICATION OF PARMER COUNTY"

NUMBER 17

SEVENTY-SIXTH YEAR

25 CENTS

Bowery saw changes here

(Editor's note: An all-day open house is planned Dec. 31 at City Hall to honor Janie Bowery)

City Clerk Janie Bowery is retiring after more than 25 years of service to Farwell. During those years Mrs. Bowery saw many changes in the city.

"In 1962, we had an old wooden water tank for water and a ground storage tank. We replaced the wood with metal tanks. Now we have three steel tanks for water storage."

Farwell is blessed with good water that has fluorine in it naturally. The city only has to add chlorine to it to keep it becoming contaminated in the pipes.

Mrs. Bowery's job includes preparing the water bills each month. "When I first came here, we did all the billing by hand. Then we had an old Burroughs billing machine that added extra numbers. Now we have a machine that is like a mini computer."

When Mrs. Bowery took the job, the City Clerk's office did not only do the water billing, but taxes and city business. Mrs. Bowery became the first person certified to be a tax assessor in Parmer County. The law was later changed so that taxes were done by the Parmer County Tax Assessor's office instead of the city.

In 1972, the city government moved from the American Legion building on First Street - the white building next to the log house - to its present location on the corner of First Street and Avenue A.

In 1973, the paving project was finished, so that all the streets in town had curbs and gutters. "It certainly makes a big difference," said Mrs. Bowery referring to the paved streets and curbs. Mrs. Bowery remembers the muddy days before paving.

The current sewer project is now almost completed. It is in its performance period. "We haven't gotten all the money from the EPA for their share of the project, but the work is all done," said Mrs. Bowery.

Another change, is that the city of Farwell took over the management of the cemetery.

Changes in laws keep Mrs. Bowery busy. The city clerk must be well versed in such diverse legal matters as election laws and health department regulations concerning the disposal of trash. The Secretary of State and the Texas Municipal League provide information about legal change. The city clerk has to read them, and make sure that the mayor and council are made aware of changes

that are mandated by the state and federal governments so that they can make the necessary changes.

The city of Farwell must follow strict regulations for proper handling of the town's water, sewage and refuse. The city clerk handles correspondence on these matters. "Farwell has plenty of landfill space," said Mrs. Bowery. "At current level of use, we have enough space until about 2050."

Often the city clerk is asked to tell other city employees what work the mayor and councilmen need them to do. "They all say I'm a slave driver," she laughs.

Mrs. Bowery served as City Clerk under five mayors, Sam Aldridge, Elmer Hargrove, Gil Patschke, Walter Kaltwasser and Chris Gikas.

She worked with commissioners J.E. "Eb" Randall, Clarence Christian, Woodrow Lovelace, Joe Blair, L.R. "Jelly" Vincent, Ralph Franse, Jim Berry, and Jerry Monk.

Two years ago, Farwell changed from a commissioner to aldermanic form of government. The current council includes Liz Phillips, Martin Kube, Curtis Smith, Ysletta Kittrell, and Fred Chandler.

"I've seen a lot of people come and go," says Mrs. Bowery. As city clerk, she is

often one of the first people that newcomers to Farwell meet.

"We have had all kinds of people come in here," says Mrs. Bowery. "One day I was working when a very big woman came in to the office."

"Where you got my husband?" she demanded loudly. "I didn't know what to say to her," Mrs. Bowery said.

It turned out that the lady's husband was in the Parmer County Jail. She had come to city hall by mistake.

"We always have people coming in here to get married or to pay for their car tags," she said. "Once in a while we get a threat or a complainer, but most people are real friendly."

During the years that she clerked, she watched her six children grow and marry. "I had all six of my children in a 7 1/2 year span."

Mrs. Bowery now has 14 grandchildren, the oldest of whom is a high school senior. Three of her grandchildren were born on the same day. It was hard to tell which hospital to visit first.

Mrs. Bowery plans to do more arts and crafts shows and to travel during her retirement. "I've had a lot of fun doing arts and crafts," she commented about her hobby.

New tracks arrive

The new tracks to be placed over the highway between Texico and Farwell arrived Monday, it was noted at Tuesday's Texico City Council meeting.

Texico and Farwell officials have long worked to get the Santa Fe tracks replaced. Last year, the states of New Mexico and Texas al-

located funds for the work. It's doubtful, though, that the tracks will be replaced over the highway until warmer weather.

Meanwhile, Santa Fe workers are eliminating one track, moving the switches and re-aligning another track.

Some of the work awaits a

(Continued on Page 8)

Filing deadline nears

1988 is an election year for some Parmer County posts.

The deadline for filing for county offices is 6 p.m. Jan. 4, reports Parmer County Clerk Bonnie Warren.

The county offices that are open are Parmer County Commissioners from Districts 1 and 3, tax assessor, county sheriff and county attorney.

The district attorney's office is also up for election, but it is a state office, and applications are filed with the Secretary of State's office.

The following people have filed for office so far (all on the Democratic ticket):

Tax assessor: Pat Howard, Doris Herington and Bernice Pennington.

County sheriff: Bob Davis and Jerry Atchley.

Both incumbents have de-

clared for their County Commissioner posts: Ernest Anthony, Friona, and Robert White, Farwell.

Candidates for county offices must first file a form appointing a treasurer of their campaign fund with the County Clerk's office.

Then the candidates file with the chairman of the political party they will represent. Wendol Christian is the chairman of the Democrat party in Parmer County. Garvin Thorn is the chairman of the Republican party in Parmer County.

There is a filing fee which must be paid at the time of filing for office. It varies from office to office, but all of the county filing fees for this election range from \$300-\$600.

TPA
MEMBER 1987
TEXAS PRESS ASSOCIATION

STATE LINE TRIBUNE
Box 255
Farwell, TX 79325
USPS 520 220

Second-class postage paid at Farwell, TX 79325
Published weekly at 404 3rd St., Farwell, TX 79325

Mike Pomper, publisher
Judy Pomper, co-publisher
Betty Castleberry, advertising

SUBSCRIPTION RATES:
Parmer and adjoining counties,
\$10.63 per year; elsewhere, \$18.06.

Obituaries



Minnie Ramm
Minnie Ramm

Services for Minnie Ramm, 80, of Farwell were held at St. John's Lutheran Church in Lariat on Dec. 22. The Rev. Mac Bearss officiated.

Burial followed at Lawn Haven Memorial Garden Cemetery, Clovis, under the direction of Ellis Funeral Home.

Mrs. Ramm died Dec. 19 at Farwell Convalescent Center. She was born Nov. 16, 1907 in Lee County, Texas. She moved to Farwell from Lexington in 1925. She married Eddie Ramm on Jan. 3, 1928 at Lariat. She was a member of the St. John Lutheran Church in Lariat.

She was preceded in death by her husband in 1983.

Survivors include two sons, Ernest, of Muleshoe, and Fred of Carthage, Mo.; one daughter, Alice Huggins, Clovis; one sister, Velma Zoch, Clovis; one brother, Ludwig Kube, Borger; nine grandchildren, and 11 great-grandchildren.

Eunice Shuping

Services for Eunice E. Shuping, 86, of Kress were Saturday in Morrison Funeral Home Chapel with the Rev. H.L. Stevens, a retired Church of God minister, officiating.

Burial was in Dumas Cemetery under the direction of Morrison Funeral Home.

Local arrangements are by Lemons Funeral Home of Plainview.

She died Dec. 16 in Plainview's Heritage Home after a lengthy illness.

She was born in Missouri and moved to Kress in 1950. She married Jody Lee Shuping on Aug. 1, 1930, in Frederick, Okla. She was a babysitter and a member of the Church of God.

Survivors include her husband; three brothers, Theron of Lazbuddie and Walter and Edgar, both of Frederick; two sisters, Tomilene Hutchison of Vici, Okla. and Nollie Trieder

of Lazbuddie; a grandchild and two great-grandchildren.

Eloyce Graves

Services for Eloyce Washington Graves, 68, of Friona were Dec. 23 in Calvary Baptist Church with the Rev. Hazel Norrid, pastor of First Assembly of God, officiating, assisted by the Rev. C.C. Slay, pastor of Second Baptist Church of Progresso.

Burial was in Muleshoe Cemetery under the direction of Ellis Blackwell Funeral Home.

She died Dec. 19 in Parmer County Hospital after a long illness.

She was born in Castle, Okla., and moved to Friona in 1958 from Farwell. She married Henry Graves on Dec. 20, 1953, in Clovis. She was a member of the Secoñd Baptist Church. A son, Larry, died in 1977.

Survivors include her husband; two sons, Henry Jr. and James Otis Norman, both of Friona; a sister, Mrs. Frankie Ellis of Los Angeles; three brothers, Curtis Washington, Elise Washington, and Roosevelt Washington, all of Hanford, Calif.; and nine grandchildren.

Pierce resigns

Janette Pierce announced her upcoming resignation as home economist for Parmer County at Tuesday's Parmer County Commissioners' meeting.

Mrs. Pierce has taken the post as 4-H home economist for Curry County. She and her husband, who currently live in Farwell, will move to a site they own just north of Cook's Truck Stop.

Her last day as a Parmer employee will be Jan. 15.

In other business at the meeting, the commissioners turned down a request for retirement pay for the past several years be allowed for the district attorney's investigator.

Courthouse Notes

Instrument report ending Dec. 18 in County Clerk's Office, Bonnie Warren, County Clerk.

Cor. WD- Launa B. Trieder Donham- Zelma Foster P.O. Box 510 Farwell, Texas 79325, all of lots 5-7, Blk. 26, OT Farwell.

Spec. WD- Secretary of Housing & Urban Dev. Star Route, Bovina, Texas 79009-Donald James Mason, NE 1/4 of Sec. 28. T7S; R2E.

Here are some last-minute tax tips

Here are some last minute tax planning tips from CPA Jack Allan Kirkland:

In light of the sweeping changes in the tax law made by the Tax Reform Act of 1986, year-end tax planning has never been more important. While individual tax planning should be suited to meet each taxpayer's needs, the following tips may prove beneficial to most taxpayers:

IRA's - If you or your spouse is not covered by an employer's qualified pension plan, you may still be able to deduct an IRA contribution. If you are self-employed and your spouse assists you in your business, consider paying her wages so that she may take full advantage of the IRA deduction. If your spouse has never had an IRA before, you must open an account in her name by Dec. 31, 1987 to take advantage of the deduction this year.

Income Deferral - If you are on the cash basis, defer what income you can until 1988 when the tax rates are generally lower. Certain types of income, however, can not be deferred and you should consult your tax advisor if you are in doubt about your situation.

Accelerate Deductions - Again, with tax rates being higher this year, year end deductions mean more money in your pocket. Pay allow-

able deductions before Dec. 31, especially any interest on consumer debt if you can itemize deductions as it loses another 25% deductibility.

Income Shifting - If you are a sole proprietor you may be able to decrease your tax liability by paying wages to your spouse or minor children. Such wages are generally not subject to social security taxes. However, as the laws may have changed drastically for reporting income of minor children, consult your tax advisor before doing so.

Passive Losses - If you are a landlord or have other passive income, consult your tax preparer to determine whether any losses from those ventures is still deductible.

Keough Plans - If you

have net earnings from self employment, you may be able to contribute a substantial amount of money to Keough Plan in addition to or in lieu of an IRA.

Charitable Deductions - For 1987 (as opposed to 1986) charitable contributions are only deductible if you are able to itemize deductions. It will generally be more difficult to in 1988 because the standard deduction increases, so consider making next year's contributions this year.

Capital Gain - While the capital gain exclusion is gone, income from sale of capital assets still retains its nature and gains can be used to offset capital loss carryovers. Also, the maximum tax rates for capital gains is 28%.

It's a Boy

Taylor Crooks

Taylor Brian Crooks was born Nov. 20 at Presbyterian Hospital in Albuquerque. He is the son of Britt and Tonye Crooks. He weighed 8 lbs. 8 oz.

His maternal grandparents are Moreland and Jane Harrington of Pleasant Hill Maternal great-grandparents are Mr. and Mrs. Garland Harrington of Clovis and Rebecca Starcher of Carlsbad, N.M.

Paternal grandparents are Arlye and Margie Crooks of Texico. Paternal great-grandparents are Mr. and Mrs. R.E. Crooks and Ruth Reid of Texico.

Semi-Annual Clearance Sale

Mens', Ladies' and Childrens' Shoes

1/3 to 1/2 off

Womens' Hushpuppies and Daniel Green

Mens' Freeman, Daniel Green and Hushpuppies

Childrens' Hushpuppies

For The Finest In Fashion, Quality And Service

TURN TO

Woody's

520 Main

Woody's Charge

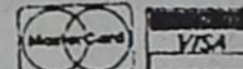

Sheriff's Report

Here is the weekly report from Parmer County Sheriff Bill Morgan.

Brent Black of Farwell reported that someone had broken into his shop on the night of Dec. 20. Several items were taken. Incident is still under investigation.

On Dec. 20, Pedro F. Garcia, 20, Clovis, was arrested by the Texas Highway Patrol on a charge of driving while intoxicated and evading arrest. He pled guilty before County Judge Porter Roberts and was fined: DWI - \$250, court cost and 3 days; evading arrest- fine \$200 and court cost.

On Dec. 20, Pedro Antonio Sanchez, 27, of Los Angeles, was arrested by the Texas Highway Patrol on a charge of driving while intoxicated. He pled guilty before Roberts and was fined \$250, court cost and 3 days in jail.

Fire Calls

There were no Texico fire calls during the past week. Farwell had one call.

On Dec. 20, the ambulance was called to 511 5th at 9:38 a.m. A patient was transported to Clovis High Plains Hospital.

Winners reversed

The winner of the TV set given away by the Farwell Booster club at the Farwell Invitational Basketball Tournament was Willie Roberts. The winner of the remote control car was Marianne Price.

Last week, the Tribune had the winners reversed.

EXCEL

Friona Division

Wishes to express Season's Greetings to all employees and their families through the Christmas season. Please have a safe and prosperous New Year.

Merry Christmas

from Rip's Western Wear and it's employees



Tommy, Karen, Roy, Mike and Nikki Snodgrass, and Maxine Shaw.

Rip's WESTERN WEAR

IN TEXICO

SINCE 1943

CHRISTMAS

Greetings

May yours be a Christmas of hope and peace

and may you have a prosperous New Year!

TO ALL OUR FRIENDS & NEIGHBORS

Kenneth R. Henry Ronnie Holt
Darlene Henry Kathy Lindley
Rama Smalling

Henry Insurance

111 W. Ave. B-Muleshoe, Tx. 79347

806/272-4581

Lady Wolverines go 9-1; Steers place 2nd in tourney

The Texico Lady Wolverines, now 9-1 on the season, crushed Grady 72-31 on Dec. 18.

Leading the scoring for the Wolverines was Tracey Askew, who scored 6 baskets and 3 free throws. She also had 12 rebounds.

Andria Chadwick made 7 baskets, 6 rebounds, 4 steals, and 4 assists.

Twilla Longo made 5 baskets, 6 rebounds, 7 steals, and 1 assist.

Valerie Cavallero made one basket and 4 free throws. She stole the ball 4 times.

Angie Liggins and Denise Gonzales each had 3 baskets and Gonzales also made one free throw and four steals.

Robin Pierce made 2 baskets and 3 free throws. She stole the ball 3 times. Geneva Garcia had 1 basket and one free throw along with 8 rebounds and 4 steals and 7 assists. Leslie Steward made 1 basket; she had 2 rebounds, 8 steals and 3 assists.

The Lady Wolverines defeated Fort Sumner 49-21 at Fort Sumner on Dec. 19.

Tracey Askew made 6 baskets and 4 free throws; she also had 12 rebounds in the game. Leslie Steward made 4 baskets and 1 free throw; she also had 4 steals and 3 assists.

Andria Chadwick made 2 baskets, 3 free throws, three steals and one assist.

Vallerie Cavallero made 2 baskets and 3 steals. Twilla Longo made 1 basket, 1 free throw, 7 rebounds, 3 steals, and 4 assists. Geneva Garcia made 1 free throw, 7 rebounds, 3 steals, and 4 assists.

Texico's J.V. girls defeated Portales 45-25 on Dec. 8. The team now has a 3-1 record.

Denise Gonzales led the scoring with 15 points. She made two 2 point baskets, three 3 point baskets, and 2 free throws. She also had 4 rebounds, 2 steals and 1 assist.

Jennifer Gentry made five 2 point baskets, and 4 free throws. She also had 9 rebounds, 3 steals and 2 assists.

Amy Chadwick made a trio of 2 point baskets, one 3 point basket, 4 rebounds, 5 steals and 3 assists. Valerie Cavallero made one 2 point basket and 1 free throw. She also had 2 rebounds, 4 steals and 1 assist.

Dena McDaniel had a 2 point basket, 2 rebounds, and 1 steal. Krystala Cross had 2 free throws and 6 rebounds. Penny Pierce made 2 rebounds, 2 steals, and 2 assists, while Leslie Cox had 2 rebounds.

The Texico 7-8 girls' team was beaten by Floyd 29-27.

The Texico girls had the lead at the end of the third quarter, only to slip in the fourth. The team now has a 3-1 record.

Jessica Gutierrez led the scoring with nine points. She also had 9 rebounds, 8 steals, and one assist.

Marsha Hamilton scored 6 points. She had 5 rebounds and 4 steals.

Regina Isaac, Chanda Campbell, and Leslie Servatius all made 4 points. Isaac also had 5 rebounds, 7 steals and one assist. Campbell made 3 rebounds, 1 steal. Servatius made 2 rebounds and 1 steal.

Farwell's J.V. boys could smell success, but it eluded them two out of three times at the Sudan Tournament.

In the opening game, Farwell beat Muleshoe, 49-40. "They played real well," said coach Gary Cates. Michael

Day scored 28 points.

On Dec. 19, in the morning game, Abernathy won, 61-60 in an overtime. "We missed a few easy shots late in the game, but overall the team played very well," said Cates. Day scored 27.

Later in the day, Farwell lost to Sudan in double overtime, 44-43.

"It was really hard luck. We were still tired from the morning. We came out flat, and didn't play as well as we could have," commented Cates.

"The team has improved some. As a team, they showed good defense and good rebounding through most of the game," he added.

Farwell's J.V. girls were winners of the consolation trophy at the Sudan J.V. Tournament Dec. 18-19.

"It is the first time in a long time that Farwell girls have won any trophies," said Coach Patsy Camp.

The girls were beaten by Muleshoe by 20 points in the first game.

"Kelly Brown was the high scoring player in the game. Lisa Geries played good defense," said Camp.

The seven girls on Farwell's team were pressed the entire game by Muleshoe's (a 3-A school) 15 girl squad.

On Dec. 19, Farwell defeated Petersburg, 28-12.

"Petersburg is a 2-A school, but they are pretty close to us in size. The size of their players and the size of their squad was more like Farwell's than any team we have played this year," said Camp.

"We started out kind of sluggish, but then we came back during the last two quarters. Kristy Treadway and Kaci Stephens saw lots of play in this game; when you are down to seven on a team, everyone has to work hard," said Camp.

"The team is really improving," she added.

Farwell was slated to meet Kress in the final game of the tournament but Kress cancelled due to injuries, allowing Farwell to win the consolation uncontested.

"I was really thrilled that each girl got an individual medal for playing; I'm really proud of Kaci Stephens, Kristi Treadway, Angie White, Kara Camp, Kelly Brown, April Haseloff, and Lisa Geries," said Camp.

Workouts start on the Saturday after Christmas.

Farwell played Sudan on Dec. 15 in spite of the storm that closed the schools. Farwell beat Sudan 70-61.

"We played early due to the weather," said coach Larry Gregory. "We feel good about the win. Sudan has a quality team; they will make the district playoffs.

We were also pleased by the dedicated fans who turned out for the game despite the weather," he added.

On Dec. 17, Farwell squeaked by Vega to win their first game in the Bovina Tournament 72-71. The game was played in Farwell.

"This was the first time in 10 years that Farwell has beaten Vega," said Coach Larry Gregory. "Vega was a regional finalist this year; we were pleased to beat a quality team like Vega."

Gregory noted that Vega had only had two weeks of

Three Farwell Steer players were named to the All Tournament Team at the Bovina Tournament. They were: Greg Actkinson, Shawn Stewart, and Abel Lopez.

practice time this season, and they will get better as the season goes on.

Farwell had a 16 point lead early in the game, but the score evened up in the third quarter. Farwell fought back in the fourth quarter, and Damon George sunk a three point shot in the final seconds to pull ahead of Sudan.

Scoring for Farwell were: Damon George, 14; Shawn Stewart, 11; Dustin Hardage, 8; Monte Delgado, 6; Greg Actkinson, 4; and Abel Lopez 4.

Farwell Steers defeated Canyon J.V. 66-50 at the Bovina Tournament on Dec. 18.

"The team played well enough to win," said coach Larry Gregory. "They did a good job defensively."

Scoring for Farwell were: Damon George, 14; Shawn Stewart, 11; Dustin Hardage, 8; Monte Delgado, 6; Greg Actkinson, 4; and Abel Lopez 4.

"Our shooting was off, and there were 25 turnovers in the game. We can't play that way against a team like Bovina," said coach Larry Gregory.

"We came back in the third quarter from being behind by 18 points to being only three

points behind," said Gregory. Leading scorers from Bovina were Damon George, 14, and Shawn Stewart, 11.

The Farwell Steerettes lost two games and won one at the Bovina Tournament to bring their season record to 4-10, which is already better than last year.

In the first game, Farwell was outmatched by Vega 69-31. Scoring for Farwell were Amy Murray, 14, and Laura Wolfe, 11.

In the second game, the Steerettes defeated Plains, 50-19. Amy Murray and Laura Wolfe led the scoring with 14 and 11 respectively.

"They played an excellent game, the best of the year," said Coach Fred Libby. "I'm proud of the girls."

"Laura Wolfe played two of her best games against Plains and Dimmitt JV," said Coach Libby.

In the third game of the tournament, the Steerettes

(Continued on Page 5)

SAVINGS SPREE!
30%-50% OFF
 SELECTED FALL AND WINTER MERCHANDISE
 SALE STARTS Saturday, December 26th
 "Our Personal Service Makes The Difference!"
MODE O' DAY
 313 Main 762-7002



Wishing Christmas Spirits
Bison RV Center
 David, Betty, Jim & Bill
 1200 E. 1st, Clovis



Steve, Helen, Brian & Cari

Old-Fashioned service
 Old-Fashioned prices
Merry Christmas
United Drug
of Farwell

Christmas spirit is singing out all over the land. We add our voice, wishing you and yours the finest of holidays! Have the Merriest Christmas yet!



BEALY Furniture INC.
 601 Main - Clovis 763-7121

THE ENCHANTED SUNMARK
 1208 PILE 762-2044 MON-SAT
 CLOVIS, NM 10:00-5:30
 A Unique Bookstore

AFTER CHRISTMAS SALE
 Christmas Books 30% off
 Soft Toys 50% off
 All Christmas Items 1/2 price
 (Christmas Cards, ornaments, etc)
 Selected Books 25% off

Season's Greetings



May you share richly in all the blessings of this Holy Season:
 The Joy of Christmas,
 which is love,
 The Gladness of Christmas,
 which is giving,
 The Glory of Christmas,
 which is salvation, and
 The Benediction of Christmas,
 which is Peace.

Curry County Grain & Elevator Co. Inc.

“Serving Farmers In This Area For Over 50 Years”



NORTH CLOVIS
762-7492

WEST CLOVIS
762-4531

GRADY
357-2293

ROGERS
477-2257

DOWNTOWN CLOVIS
762-2946

PLEASANT HILL
389-5340

GRIER
985-2271

MELROSE
253-4271

CCG

Curry County Grain
and Elevator Co., Inc.



Yule

(Continued from Page 1)

me? Will he put me in an old toy box? I hear him coming; the time has come. I will know for sure if he likes me or not.

Quickly he tears at the wrapping paper that encases me. Piece by piece the paper is torn away. I can see the lights of the Christmas tree. Finally the last piece is torn away, and he looks at me with love. Now I see the joy I was hoping for.

I will never forget today I know, not even when I am raggedy and old. I will always remember his first words to me, "I will always love you, my fuzzy blue rabbit."

The Christmas Angel
Monica Ann Potts

Well, it's time for Christmas, and they are getting me out of my box again. It gets really lonely being up in that attic in a box by myself. So I'm always glad for them to bring me down. To me, it's a treat to get to see all of the house decorated for this time of year.

I've been in the family a long time. They keep putting me back on the top of the tree, year after year. My dress is getting kind of yellowish, and a few years ago the father wanted to throw me away. The kids decided, though, that it just would not be

Christmas without me.

I've stood on the top of artificial trees, and I've stood on top of real trees. Through the years, I've not been able to decide which has been the prettiest. The spirit of Christmas is always strong, and everyone seem to be full of joy at this time of year.

I had never really understood what the true meaning of this holiday was all about, until a few years ago when I heard the grandmother telling her granddaughter that Christmas is the time when they celebrate the birth of their Savior. Now I can see why this is such a special time of year. I had always thought it was just a time of giving presents.

I had a feeling, though, that this is going to be the best Christmas ever. So, "Merry Christmas and Happy New Year."

The Happy Candy Cane
Monica Salguero

Tasting me is a delight. I am red with white stripes. I taste like peppermint. I come in two sizes, big and small. When I'm bought, I'm usually put on the tree, into the stockings, or on presents.

I waited patiently in a box with all my friends to be bought and hung on the Christmas tree. I hang from the top of my cane on the branches. I see all the

Night Watch

The First Baptist Church of Texico will have a Night Watch service on Dec. 31.

ornaments that have been put on the tree. They are above me and on the other side of the tree. I'm really close to the Santa Claus ornament. To me, he looks as if he is about three inches in height. He is on the plump side and has pudgy red cheeks and a tiny noses that is red on the tip. There are other ornaments on the tree, but I cannot see them that well.

I can see the presents that the kids and parents are getting. I watch the parents sneaking around at night, wrapping the presents, and I also see the kids sneaking around to see what they have gotten. On Christmas morning the kids tear into their presents. Then later that day the kids start taking my friends and me down to eat.

The Diary of a Christmas Tree
James Phipps

I was brought from the attic on Dec. 10, a cold, chilly night. The kids screamed and the parents calmed them. They brought out all the ornaments that they were to put on me, and there were a lot. When they got through, I was tired from all the, and still I had to wait for Christmas.

On Dec. 24, about one o'clock in the morning, I was seeing everything. The parents scurried around getting everything from their hidden places. The kids were in a light sleep, eager for the next day, but I was not looking forward to the next morning. I knew the kids would jump out of bed and run for me

and the presents under me.

On Dec. 25, at about noon, I had lost my glamour. The kids had opened their presents, and I was left looking like a half beaten tree.

On Dec. 27 I was taken down, after all the fun and stored in a box to be put back into the dark attic.

A Gift in a Box
(Christmas from a Teddy Bear's Perspective)

Ysidra Martinez
As Christmas nears, I may sit in many stores waiting to be bought and given as a gift to make someone happy. Later, I am put into what felt like a square box. I cannot move much, but I have enough room so that my arms and legs do not touch the box. I can only see the darkness. I know when I am being wrapped because I hit the sides of the box as they turn the box. I cannot see what is going on, but I can hear the plans of each household member as they came to the Christmas tree to think about what to get each member.

The best thing I see, in my mind, on Christmas day is a little girl slowly creeping down the stairs to the entrance of the living room. She barely peeks into the living room to see if anyone is there. She then burst out screaming, runs toward the Christmas tree, falling to her knees and grabs the biggest box, which happens to be me. She starts to tear off all the wrapping paper. She finds the opening, and pulls me out of the box. She

gives me the biggest hug in the world.

The Silent Night
Leonor Chavez

One snowy, silent night in a dark house where no one was awake, I peeked out of my mouse hole to see if anyone was around. I heard bells that seemed to get closer and closer to the house. I got a little frightened, but I was too hungry to let bells scare me. I was entering the living room, when suddenly I heard a loud, weird sound. I ran and hid underneath the couch to see what was going on. I was even more scared.

Suddenly out of the chimney fell a fat man in a red suit trimmed with white wool. He had a beard and hair nearly as white as the snow on the ground, with

a hat the color of his suit on the top of his head. His eyes danced with glee as he began to pull packages out of his bag. Placing the packages underneath the Christmas tree, he caught me staring at him. When he saw me he gave me a wink and made a jolly "Ho! Ho! Ho!"

Before I could ask any questions, he was gone up the chimney. As I ran to the window, I remembered my mom telling me about Santa Claus being a jolly fellow. When I reached the window, he was in the sky on the sled. His last words were "Ho! Ho! Ho! Merry Christmas."

More stories next week

It's birthday time for Taryn & Kaylee Black

They're 1 year old and they want to celebrate along with everyone as their way of thanking Farwell. So y'all come! No gifts; just bring yourself.

Come & Go

3 to 4:30 p.m., Sunday, Dec. 27th
Farwell Community Center

'We want a trampoline'

Dear Santa,
I would like a concho with a red bear, and a home for people who don't have one.

Love,
Krista Smith
Grade 4 Lazbuddie

Dear Santa,
I want a pair of skates. I want any kind of doll. The last thing I want is a new pretty coat. I hope you have a Merry Christmas and that you read my letter.

Love,
Socorro Reyes
Grade 4 Lazbuddie

Dear Santa,
Please bring me a chemistry set and a paint set. Thanks.

Love,
Dawn Weir
Grade 4 Lazbuddie

Dear Santa,
I love Christmas. Not just the presents, but the family get together. My brother and I want a trampoline together. Thanks.

Sincerely,
Julie McDonald
Grade 4 Lazbuddie

Dear Santa,
I would like three things. First, I would like a Jill doll. Next, I would like a diary with a key and a lock. Last I want a big Spuds Mackenzie doll.

Love,
Heather Engelking
Grade 4 Lazbuddie

Hospital Notes

J'Dan Sudderth is in North-west Texas Hospital Pavilion, PAC Unit, 7201 Evans, Amarillo, TX 79106. Cards would be appreciated.

Eva Nell Sewell is home from the hospital after a stay in Methodist Hospital.

Farwell

(Continued from Page 3)

were beaten for the consolation game 36-31 by Dimmitt.

Laura Wolfe and Amy Murray each had 10 points in the game.

Coach Libby summed up by saying, "We aren't consistent at this point, but we are improving."

Farwell to vie in tournament

Farwell teams will compete in the Sudan Tournament on Dec. 29, 30, and 31. Games start on the 29th at 2:30 p.m. The Steerettes will play Lovington J.V. at 4 p.m. on the 29th.

"This will be a real strong tournament," said coach Larry Gregory. "The boys will compete against teams like Lovington, Sudan, Wellman, Nazareth, Vega, Lubbock Christian, and Lorenzo. Steerettes will meet teams like Nazareth, Sudan, Farwell, Lubbock Christian, Muleshoe, Wall, and Lovington J.V."

The Farwell teams will meet Vega here on Saturday, Jan. 2. The J.V. girls play at 3 p.m.; the J.V. boys play at 4:30 p.m.

The Steerettes play at 6 p.m.; the Steers play at 7:30 p.m.

Dear Friends, we have contributed the money usually spent by our family for Christmas cards to be used by Farwell Elementary.



To wish you all the Joys of Christmas

- Johnny, Diane, Jeff, Greg, Jill & Lacey Actkinson
- Frank, Eva, Cynthia & Michael Ancira
- Bob & Carrie Anderson
- Ron, Lance & Brock Anderson
- Chacho, Maria, Michael, Kristopher & Katrina Arce
- Charles, Margaret, Chris & Karen Aycock
- Ana Maria Banuelos
- The Bearss - Pastor Mac, Jennifer, Kim, Greg & Suzi
- Mr. & Mrs. Jim Beavers
- Ricky, Ruth Anne, Reace, Roslyn & Ramsey Bennett
- Jim Berry
- Patsy & Janene Berry
- Kay, Shelly & Jamie Bethel
- Lois Billingsley
- Ruby Billingsley
- Mr. & Mrs. Delbert Black & family
- Ros, Ginny & Lynn Blankenship
- Bill & Louise Brigham
- Nancy Burch
- Lynn, Cheryl, Erik, Heather, Ivan, Hayley & Heidi Burton
- Ronald, LeAndra, Chad & Quinn Byrd
- Capitol Foods
- Howard & Billie Carlyle
- Fred & Dickie Chandler
- Martin, Edith & Mark Chandler
- Sallie Chandler
- Elvis & Lovelle Childs
- Mr. & Mrs. Chase Chisman
- Carrie Christian
- Charlie Christian
- Donald, Dot & Charles Christian
- Mr. & Mrs. Troy Christian & Todd Christian
- Wendol & Louise Christian
- Floyd & Wynona Coates
- Claude Coffey
- Jim & Margaret Coleman, Ricky, Lyna, Jamie & Jered Coleman
- Tony, Diana, Neshell, Crystal & Michael Johnson
- Paul, Sandy, Tasha & Kasey Adams
- Ed, Gwen, Clay, Christi, Charla & Clint Corn
- Bill & Rubie Craft
- James & Nelle Craig
- Edith Crawford
- Linnie Mae Crook

- Eunice Crume
- James Curtis Family
- Leslie, Kathy, Brett & Josh Curtis
- Martha Curtis
- William & Lorine Dannheim
- Jerry, Flo & Todd Davis
- Wesley, Cindy, Candy & Jeff Davis
- Bill, Launa & Meghan Donham
- The Charles Duncan Family
- Ronny, Candy, Rob & Aaron Dyer
- Marilyn Edwards
- Ruby Edwards
- Shawna Edwards
- Floyd, Betty & Eldon Embry
- Ted & Lennie Engram
- J.W. & LeeNell Eubank
- Farwell Gin
- The Virgil Fiske Family
- Gary, Joey, Robbi, Kirk & Jody Fly
- Doyle & Doris Ford
- Uvon & Faye Ford
- Jim, Susan, Jarrod, Julie & Paul Franse
- Pete & Tommie Fulcher & Tonda
- Phil & Dolores Garrett
- David George Family
- Chris & Peggy Gikas & Manabu
- The Webb Gober Family
- Mary Helen & Hubert Gohlke
- Enrique Gonzales & Family
- Larry, Robin, Gage & Grant Gregory
- Mr. and Mrs. John Grigsby, Amber & Zach
- Francisco Gutierrez & Family
- The Pat Halverson Family
- Elmer & Peggy Hargrove
- Adolf & Mildred Haseloff
- The James Haseloff Family
- The Jerry Herington Family
- Rodney, Priscilla & Lisa Herington
- Buttons & Judy Howard
- Pat Howard
- Golma & Bill Hubbell
- Carol Dean Huggins
- Joe, Gwen & Andy Hughes
- Craig, Deon, Britney & Brice Hunt
- Lee Hutchins Family
- Quinton & Johnnie (Rundell) Jenkins
- Clarence & Doris Johnson
- Doyle, Susan, Megan & Jason Johnson
- Kenneth & Nettie Johnson
- Randy, Berta, Brian & Amanda

- Johnson
- Donald, Vicki, Jeremy, Cindy & Kristi Jones
- Pike & Donna Jordan
- Wilbert & Mary Kalbas & Family
- Gilbert, Liz & Craig Kaltwasser
- Steven, Carla, Chelsi & Daniel Kaltwasser
- Walter & Gladys Kaltwasser
- Red, Patsy, Lindsey & Lacey Kingston
- Duke, Rhonda, Brandon & Andi Kirkland
- Jack & Vicki Landrum
- The Jerry Landrums
- Leon & Mary London
- Karen & Kristi Lovelace
- Woody & Dorothy Lovelace
- Micky, Leslie, Landon, Mark & Marni Lunsford
- Jim, Angella, Veronica & Valerie Mace
- Velma Magness
- The Robin Mahaney's
- Raymond & Edith Martin
- Duane & Lila McDaniel
- J.J. & Anna McDonald
- Ophell McDonald
- Donald & JoAnn McGuire
- Marty & Donna McGuire, Ray & Amy
- The McIntosh's - Jerry, Shandra, Kasey, Shannon & Jennifer
- Otis & Modean McMillan & Melinda
- William & Dorothy McReynolds
- Clarence & Snooks Meeks
- Tim, Tori & Landon Meeks
- Jerry, Pam, Leslie, Cody & Kelsey Monk
- Richard, Sheree, Melody, Sarah & J.P. Montgomery
- Hugh, Wilma & David Moseley
- Billy & Cindy Myers & Brittany Duffield
- Tom, Terri, Logan, Jourdan, Taylor & Tate Nichols
- Lester & Frances Norton
- Harlin & Beverly Obenshain
- Mr. & Mrs. Dee Owen
- Jerry Owen & Family
- Mary Jean Patrick
- Gary, Cindy, Clint & Leesa Patterson
- Bill & Bernice Pennington
- Ben & Janette Pierce

- Mike, Judy, Patty & Rob Pomper
- Marianne, Robert, Tonya & David Price
- Maudie Primrose
- Dutch & Dorothy Quickele
- Bill & Lynn Roberts
- Billy, Gaye, Shiloh & Shane Roberts
- Willie Roberts
- Pudge, Pat & Teresa Rose
- Claude & Myrl Rose
- Bob & Ava Nell Sewell & Mamie Greenwood
- J.R., Debbie, Doug & Stacy Sewell
- Harry & Mina Sheets
- James & Tina Sides, Jacque, Jim Bob & Ginger
- Joyce, Dale & Ricky Sikes
- Eddie, Jeanne & Sheila Smith
- The Smiths - Wayne, Carole, Keith, Mike, Micki, Stuart & Ty
- Grace Snider
- The Darrell Stanton Family
- Irene Stephens
- Keith, Jane, Brent & Kristi Stephens
- The Darrell Stephens - Darrell, Eva
- Dean, Kendra, Kaci & Chanse
- Ricky, Roene, Jeffrey, Misty & Ross Stewart
- Vernon & Julia Symcox & Leonard Hillock
- Jean Travis
- Terry, Nedda, Brea & Candace Travis
- Verona & Tuck Traynor
- United Drug of Farwell
- Dora Verner
- Alice Vinton & Family
- Mitz & Nell Walling
- Foster Watkins
- A.T. & Thelma Watts
- Joel, Katherine, Boyd & Bruce White
- Bill & Sally Whitesides
- Bert Williams Family
- Bonnie Williams
- Don Williams
- Ella Ruth & Jack Williams
- Mr. & Mrs. Johnnie Williams
- Jet, Gay, Becky & April Wilmeth
- Carl, Joyce & Ron Wilson
- Mike, Leigh Ann, Chelsi & McKinzi Woods

Farwell Elementary School

The Classifieds

481-3681

Have a leaky faucet and need plumbing work done...
 Have problems with appliances, such as washers, dryers, dishwashers, disposals...
 Need your sewer cleaned (we have a rotor roter)...
 Then call:
Jim Coleman
 day: 481-3384 / night: 481-9277

BEACON ELECTRIC
 Call me for fast and fair service
TERRY WINKLES
 Lic. #25109 482-3407

The Beauty Box
 Styles, Cuts, Perms
 Non-Surgical Face Lifting
 Frances, Mardee, Pauline
 State Line Road, Farwell
 Phone 481-3441

K&J VIDEO
 Holiday Hours:
 Christmas Eve: 12-6 p.m.
 Christmas Day: Closed
 New Year's Eve: 12-6 p.m.
 New Years Day: 12-6 p.m.

O.W.'s Mobile Homes, Inc.
Owen Henson
 Joann Cook, Max Ford - Texico sales agents
 (505) 769-2897 (505) 482-9506
 3500 W. 7th 801 Wheeler
 Clovis Texico
 Lic. No. MH 452

Call your local used cow dealer for 7-day-a-week free dead stock removal.
 Call 505/763-5513 collect; New Mexico, 1-800-858-4384, or Texas, 1-800-692-4043.

Holly Punch
THE ULTIMATE PUNCH NEEDLE KITS, PATTERNS & SUPPLIES
 Free Demonstrations
 For Individuals or Groups
JEAN TRAVIS 481-3806
 103 Sandia Dr., Farwell, Tx

FARWELL BODY SHOP
 All Types of Body Work
 Check our Windshield Prices
 Insurance Claims Welcome
 Complete Restoration of Old Cars
 Windshields Installed
 Auto Painting
OPEN SIX DAYS A WEEK
BILL ROBERTS
 800 Ave. A - Farwell - 481-9002

XTRA-SPACE
 Individual Storage
 Call 481-3222
 Farwell

RE/MAX MASTER SENIOR APPRAISER
NATIONAL AUCTIONEERS ASSOCIATION
J.B. Sudderth Realty, Inc.
 Realtors/Auctioneers / Certified Appraisers
 Farwell, Texas 109 5th St.
 481-3288
 Licensed in Texas, New Mexico
 Daren Sudderth, Master Senior Appraiser
 J.B. Sudderth, Broker Jimmie Mace, Sales Associate

We need your listings NOW!
Ask about the Sellers' & Buyers' 1-year homeowners' warranty

Excellent 3 bedroom brick, 1 3/4 bath, home with fireplace, double car garage, nice storage building, fenced backyard, in a great neighborhood.
 * * * * *

Another excellent 3 bedroom brick, 1 3/4 bath, home in excellent neighborhood. Repainted and ready to sell.
 * * * * *

3 bedroom, 1 bath house in the country, to be moved. Priced for immediate sale.
 * * * * *

Nice 2 bedroom, 1 bath stucco home, 1 car garage. Located on approximately 1 1/2 acres just outside the city limits of Farwell. On city water, with cable TV.
 * * * * *

Cozy 2 bedroom, 1 bath home, large den with fire place, fenced backyard, with storage building. In Farwell.
 * * * * *

Nice 3-bedroom, 1 3/4 bath, brick home with central heat and air, 2-car garage with door lift, fenced backyard. Good location.
 * * * * *

Excellent 2-bedroom, 1 bath home in Bovina. Ceiling fans, storm windows, single garage with electric door lift, double carport, fenced backyard, patio and storage building. 1-year homeowners' warranty.
 * * * * *

Vacant lot located just outside city limits across from Farwell School.
 * * * * *

50'x150' vacant lot with mobile home hookups. Located on 9th Street in Farwell.

Let us help you with your real estate needs and your farm and residential appraisals.

NOTICE
 On Oct. 22, 1987, the Banking Commissioner of Texas closed the First State Bank of Bovina, Bovina, Texas, and appointed the Federal Deposit Insurance Corporation ("FDIC") as Receiver.
 Notice is hereby given to all persons who may have claims against the First State Bank of Bovina, Bovina, Texas, that the same must be presented to the FDIC together with legal proof thereof within eighteen (18) months from the date of the first publication of

AIRLINE JOBS available now! Earn up to \$50,000. Mechanics, flight attendants, customer service. 1 - (315) 733-6062, ext. A1870 for info/listings. 16-3tp

FOR SALE: Almost new 8" complete irrigation pump, 360 feet, 1 1/2" shaft, 2 1/2" woodlined tubing, six stage American turbine bowles (12H80) with 125 hp electric U.S. motor and furnace panel. Call Ricky Bennett, 825-3822. 5-tpnc

Nichols Hunting Guide Service
 All types of birds
 Call 762-4328

KIMBOW'S FAMILY HAIR CARE
 By Appointment
 Mon, Tues, Wed, Fri & Sat
 504 Turner, Texico
 482-9293

REPORT CHILD ABUSE
 CALL 1-800-252-5400

NEW & USED SCHAFFER DISC PARTS
 13 ACRES OF MACHINERY
 Complete Gasoline & Tractor Parts
 BUY - SELL - TRADE
 806-238-1614
 BOVINA, TX
 Day Or Night
 T-BONES EQUIPMENT & SALVAGE
 FURNISHING OUR BEST

May the blessings of Christmas be with you today and always
 Thanks to you all.
CAPROCK INDUSTRIES, INC.
 Commercial Cattle Feeders
 225-4400 Bovina

PIERCE REAL ESTATE
 482-9188
 TEXICO, NM.

CHARLOTTE PIERCE, BROKER
 512 Wheeler Ave.
 Texico, N.M.
 [505] 482-9188
 Fully Licensed
 In New Mexico & Texas

FARWELL - 2 bedroom home in excellent condition, at 207 6th St.
TEXICO - 3 bedroom home at 307 Lamar. Has had some repainting and repairs.
TEXICO - 3 bedroom home with efficiency apartment in back. 301 N. Garwood.
3 MILES WEST OF TEXICO - 15 acre tract with 3 bedroom mobile home, box car and horse corral.
TEXICO - Permanent 14' x 84' mobile home on larger corner lot with attached double garage, front porch and large covered deck on back. Has all the extras and can qualify for VA, FHA or Conventional Loan. Located at 121 Anderson. **MAKE AN OFFER!**
TEXICO - 3-bedroom home in very good condition. Seller will help pay closing costs. Located at 300 Anderson St.
TEXICO - Invest in 3-bedroom rental property at 310 Leftwich.

Legal Publications
 This Notice.
 All claims should be mailed to:
 Federal Deposit Insurance Corporation
 Midland Consolidated Office
 P.O. Box 3148
 Midland, Texas 79702
 Published in the State Line Tribune Dec. 25, 1987

HIRING for fulltime and part-time positions. Farwell Dairy Queen. 34-tpnc

FOR SALE: 480-volt electric Inject-o-meter fertilizer pump. 18 gph. \$395. Call Ricky Bennett, 825-3822. 8-tpnc

FOR SALE: Remodeled house in Texico. Beautiful, spacious, paneled, 3 bedroom, 2 bath with central heat, 1920 sq. ft. living space. New carpet & kitchen appliances. Priced low. Call 482-3214 for appointment. 17-5tpnc

FOR SALE: Honda 3-wheeler, 250R. Recently rebuilt. \$495. Call 825-3822. 10-tpnc

FOR SALE in Farwell, Texas: Nice 2-bedroom brick home with fireplace, 1,825 square feet of living area, nice attached double garage, extra large corner lot with lots of greenery and nice storage building located in excellent neighborhood. For more information, call 763-6379. 17-4tpnc

FOR RENT: 2-bedroom unfurnished apartment in Farwell. Available Dec. 1. Call 762-9500 days or 763-7149 evenings. 12-tpnc

FOR SALE: 1984 GMC Jimmy, loaded. Excellent condition. \$6,250. Call 825-3822. 10-tpnc

REQUEST FOR BIDS ON TEXAS HIGHWAY CONSTRUCTION
 Sealed proposals for constructing 326.274 miles of seal coat on various limits of US 84, US 87, IH 27, SH 114, US 385, SH 86, FM 2290, SH 214, FM 54, FM 145, FM 784, FM 788, FM 1729, FM 1731, FM 746, FM 789, FM 1799, FM 1424, FM 1294, FM 2286 & FM 2396 in Bailey, Swisher, Hale, Lubbock, Cochran, Hockley, Lamb, Castro, Parmer and Floyd Counties covered by CPM 52-2-24, CPM 52-3-20, CPM 67-2-42, CPM 67-3-44, CPM 67-5-34, CPM 67-6-38, CPM 67-7-69, CPM 130-1-15, CPM 130-2-16, CPM 130-4-24, CPM 227-3-14, CPM 302-2-18, CPM 302-3-26, CPM 302-6-10, CPM 461-1-11, CPM 461-2-15, CPM 563-4-10, CPM 754-2-8, CPM 800-1-12, CPM 800-6-6, CPM 880-5-8, CPM 968-4-2, CPM 968-5-2, CPM 1084-1-8, CPM 1126-1-8, CPM 1128-1-8, CPM 1632-1-9, CPM 1632-2-8, CPM 1635-1-13, CPM 1650-4-3, CPM 1866-1-18, CPM 2123-1-4, CPM 2125-2-4, CPM 2333-1-4, CPM 2499-1-4, CPM 2499-2-3, CPM 2499-3-3, CPM 2766-1-2, & CPM 227-4-11 will be received at the State Department of Highways and Transportation, Austin, until 1:00 p.m. January 12, 1988, and then publicly opened and read.
 Plans and specifications including minimum wage rates as provided by Law are available for inspection at the office of Edward P. Hensley, Resident Engineer, Lubbock, Texas, and at the State Department of Highways and Public Transportation, Austin, Texas.
 Bidding proposals are to be requested from the Construction Division, 11C. Greer State Highway Building, 11th and Brazos Streets, Austin, Texas 78701. Plans are available through commercial printers in Austin, Texas, at the expense of the bidder.
 Usual rights reserved.
 Published in the State Line Tribune Dec. 25, 1987, and Jan. 1, 1988.

'Santa, drive safely'

Dear Santa Claus,
 Please bring me a GoBot for Christmas. That's all I want. I've been really good all year.
 Grant Gregory
 Farwell

Dear Santa,
 I would like to get a Pet Monster for Christmas. I would also like a Farwell Steer with horns and feet.
 I've been trying to be good and mind Mama and Daddy. I'll leave you some cookies and milk.
 Gage Gregory
 Farwell

Dear Santa,
 I want a BB gun and watch and some boots on a fat skateboard with the Nintendo set. For my sister, get her some shoes and a shirt. For my brother, get him a nice skateboard and a bebe gun and watch. Get my dad a watch and boots. Get my mom some pants and jeans with shoes and skirts, and get my mom a new refrigerator.
 I love you, Santa,
 Landon Lunsford
 Farwell

Dear Santa,
 I want a My Pet Monster, Alf, Desk racer, and clock.
 Ponce Deon Billingsley

Dear Santa,
 Hi. My name is Curt Christian and I am 3 1/2 years old. I have been a good boy this year. For Christmas I want a John Deere pedal tractor with trailer, a Fisher Price gas tank and car and a firetruck. My sister, Micah, can't talk yet, but she wants some toys and clothes.
 We will leave cookies and milk for you and a carrot for Rudolph. Merry Christmas.
 Love,
 Curt Christian
 Farwell

My name is Don Anthony. I'm 3 1/2. I love you. I have been pretty good this year. Please bring a sleeping bag and a tent and a bow and arrows to me.
 Lacy is my sister. She's been ok for a baby. She needs a doll and some baby toys.
 You need to come in our house through the door. We might have a fire in the fireplace. Don't forget.
 We will leave you some chocolate chip cookies and milk to dip them into.
 Love,
 Don

Dear Santa,
 I want a My Little Pony, a sewing machine, and whatever you want to bring me. I am seven years old. In May I will be eight. My name is Valerie Annette Mace.
 Love,
 Valerie Mace

Dear Santa,
 Can I have a My Little Pony and a sewing machine? I'd also like a Make It Bake It and a pottery set. I love you.
 Love,
 Veronica Mace

Dear Santa,
 How are your elves? Fine, I hope. Can they make me a Cabbage Patch Kid for Christmas? Can they also make me some Playschool Years toys? Tell Mrs. Santa Claus "Hi" for me.
 Love,
 Lovey Actkinson

Dear Santa,
 For Christmas Aaron wants a bike and jambox. And I want a scooter and a Casio keyboard.
 Merry Christmas,
 Mandy and Aaron

Dear Santa,
 I want a B.B. pellet rifle with a scope. I want a boy's 10 speed. I would also like a pair of gray ropers and some things for my guitar. One other thing I want is a blue robe. I've been nice, and I'll be nicer by leaving you Oreo cookies and milk.
 Love,
 Troy Chadwick
 Farwell

Dear Santa,
 I would like to have a 20 gauge shotgun with some ammunition. I would be nice, also. A box of "Polo" cologne is a nice present to give me. I some model planes at the mall, and I would like to have one.
 Sincerely,
 Eric Chadwick
 Farwell

Dear Santa,
 May I have a Swiss Army knife, some army binoculars, Crash 'N Bash Demo Derby, a Stomper, a Nintendo, mini ten speed, and a Fievel? Santa, I have been nice this year. We will leave you some different kinds of Cookies and some milk.
 Love,
 Tyler Chadwick

Dear Santa,
 This Christmas I would like a boom box and a Footloose and Cindy Lopper tapes.
 Shone
 Shane

Dear Santa,
 I am a little girl who is good most of the time. I hope you and Mrs. Claus are doing okay. I would like for you to bring me a keyboard piano, a pink camera, and a washable Caabage Patch kid.
 Thank you for all of your hard work. Have a safe journey from the North Pole.
 Love,
 Brandy

Dear Santa,
 I am a little girl who is 2 years old. I have been a good girl most of the time anyway.
 I would like for you to bring me a washable Cabbage Patch baby, a play piano, and a table and chair set.
 I hope you and Rudolph have a safe journey. Please don't forget all the other girls and boys.
 Love,
 Brittany

Dear Santa,
 I am a little boy who just turned one year old. Mommy says I have been a good little boy.
 I would like for you to bring me a Busy Elephant, a Push 'N Roll truck and a fire Chief 'N Drive.
 My sisters and I will leave you a snack by our tree.
 Love,
 Bryce

Dear Santa,
 I want a horse. I also want a real pistol. I want a real cowboy. I want a bride. I want a Merry Christmas. Thank you, Santa.
 Your friends,
 Cory Winders
 Grade 3 Lazbuddie

Dear Santa,
 I want a BB gun. I want a motorcycle. I want a pair of boots.
 Roel Moran,
 Grade 4, Lazbuddie

Reves, Christian engaged

Mr. and Mrs. Jerry Reves of Golden, Colo., announce the engagement and approaching marriage of their daughter, Haley, to Todd Christian of Farwell. Mr. Christian is the son of Mr. and Mrs. Troy Christian of Farwell.

The couple will exchange vows Jan. 9, at 4 p.m. at First Christian Church, 2323 Broadway in Lubbock.

Both the prospective bride and groom attend Texas Tech; she is studying secondary education, and he is studying agricultural economics. The bride to be is a 1984 graduate of Coronado High School in Lubbock. The groom to be is a 1984 graduate of Farwell High School.

A reception will follow the ceremony. It will be held at the Green Oaks Tea Room, 66th and University, Lubbock. Friends and relatives of the couple are cordially invited to attend.

Cole, Bowman to wed

Mr. and Mrs. Paul Leshner of Clovis announce the engagement and approaching marriage of their daughter, Jenea Denise Bowman of Clovis, to Forrest Wayne Cole of Elm Grove, Wis., son of James and Lena Cole of Farwell.

The couple will exchange vows Dec. 26 at 6 p.m. at the Parmer County Courthouse in Farwell. The prospective groom is a 1981 graduate of Farwell High who currently works as a draftsman in Wisconsin. The bride-to-be is a 1983 graduate of Clovis High School and a 1987 graduate of ENMU-Clovis.

The ceremony and reception are open to all friends and relatives.



Todd Christian and Haley Reves

The Latest

Mr. and Mrs. J. W. Eubanks hosted an early Christmas celebration at their home. Attending were: Ronda and Mark Cowgill of Carrollton; D'Lynn and Johnny Hale of Lubbock; Gina Eubank, Lubbock; Alan Eubank, Lubbock; Teresa Woods of Lubbock; Betty Jean, Leslie, and Lance Castleberry of Farwell; Mr. and Mrs. Charlie Pitts of Runaway Bay, Texas.

There will be a birthday party for Taryn and Kaylee Black at the Farwell Community Center from 3-4:30 on Dec. 27. The twins are one year old. "We just wanted to thank everyone who has been so kind to us," said grandmother, Annette Black.

Phyllis Arnold has been visiting her mother, Mrs. Maureen Caywood of Texico.

Kim Bearss is home from Concordia College, Austin, to spend Christmas with her parents, Pastor and Mrs. Mac Bearss.

DeAnne Curtis is home from Southwestern Oklahoma University to spend Christmas with her parents, Mr. and Mrs. Mr. and Mrs. Jimmy Curtis of Farwell.

Geretta, Carl, and Daniel Hutchins are home from college to spend Christmas with Mr. and Mrs. Lee Hutchins of Farwell.

Patty Pomper is home from Texas Tech to spend Christmas with her folks, Mr. and

Mrs. Mike Pomper of Farwell.

Todd Christian is home from Texas Tech visiting Mr. and Mrs. Troy Christian.

Andy Pat Hughes is home visiting his parents, Mr. and Mrs. Joe Hughes. Andy has transferred from Texas Tech to Eastern New Mexico University in Portales.

Melinda McMillan is home from Texas Tech to spend the holidays with Mr. and Mrs. Otis McMillan.

A former resident of Farwell, Sam Morton, is now a justice of the peace. His father taught agriculture here for 24 years.

The Church of Christ held a sandwich and cookie supper at the church on Dec. 20.

Thank You

The family of Margaret Horne wishes to thank the Body of Christ and our fellow neighbors for the many expressions of concern of love you have shown during her recent illness.

Merry Christmas

Will close 4 p.m. Dec. 24;
reopen Monday, 9:30 a.m.

Lookin' Good

206 Main Muleshoe Phone 272-5052

JOY AND PEACE

Merry Christmas & Happy New Year

Thank you for your patronage

Adrian Photography

"When Quality Counts"

218 West Second Muleshoe, Texas 79347
806/272-3487

Multiple Choice.

Build a copier that meets your needs with the Xerox 1025 Marathon! All the features of a good-sized copier in a better size and price. Choose options and accessories now or later.

- Exceptionally high copy quality
- Fast, delivers up to 21 copies per minute
- Desktop sized to fit almost anywhere—

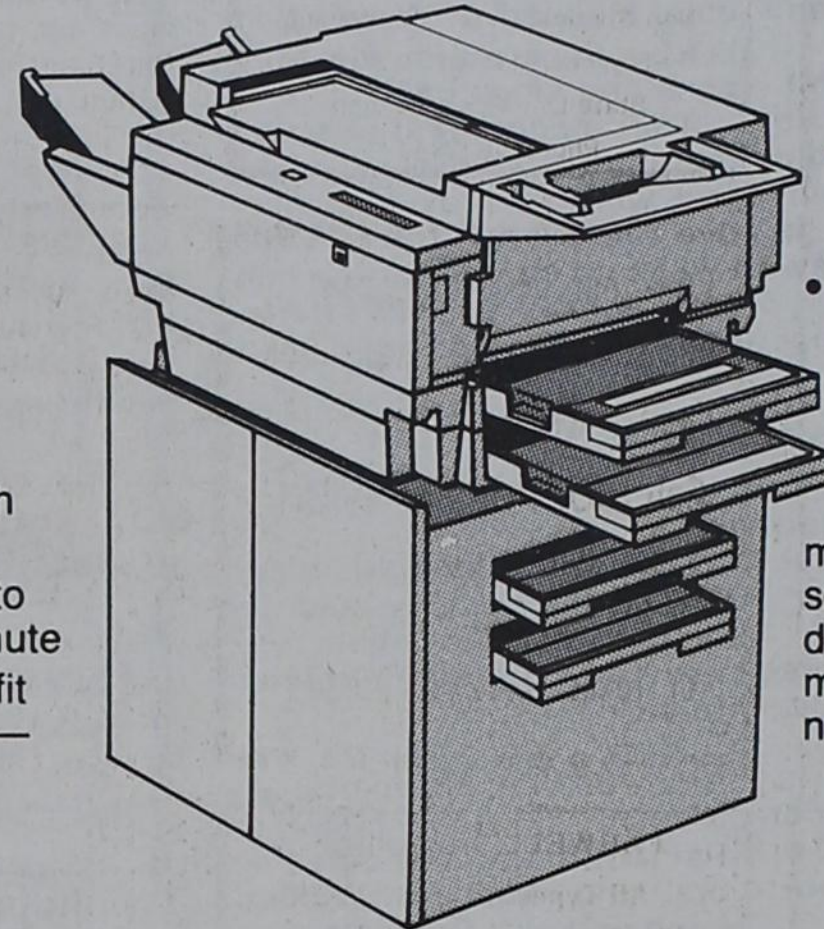

just 24" square by 11" high

- Semi-Automatic Document Handler available
- Options include: 10-bin Sorter, Three-Tray Feeder, Color Copying
- Reduction/Enlargement model with eight settings sizes documents to meet your copying needs

The world's first and only 3-Year Copier Warranty from Xerox!

Introducing the 1012 Marathon Copier.

The new Xerox 1012 is so reliable, it comes with the longest service warranty offered. You get the best warranty and the best

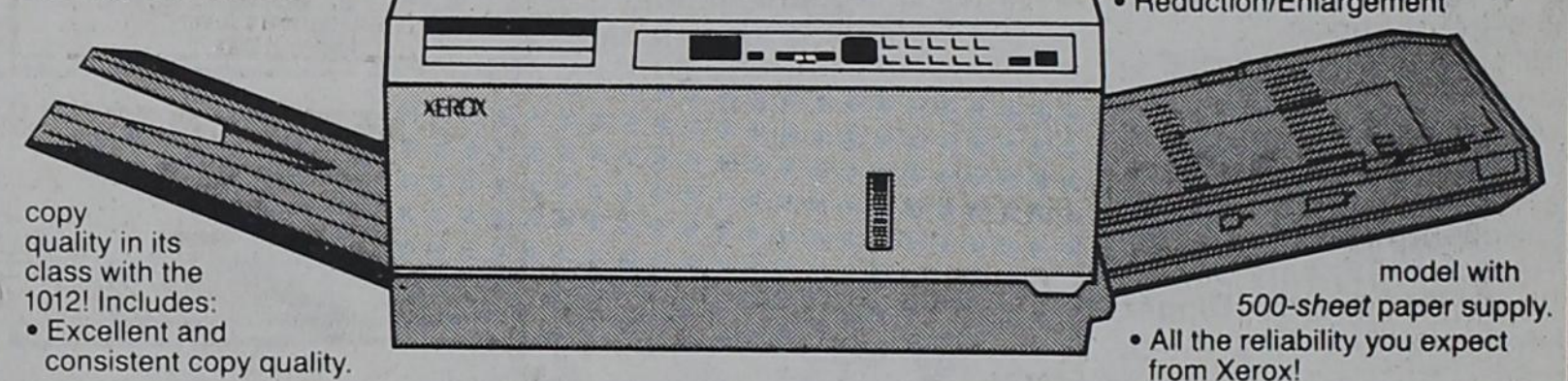

copy quality in its class with the 1012! Includes: • Excellent and consistent copy quality.

- Automatic Exposure Control scans entire original.
- Replaceable Copy Cartridges make maintenance easy.
- Reduction/Enlargement
- model with 500-sheet paper supply.
- All the reliability you expect from Xerox!

Head of the class!

The Xerox 1050 Marathon Copier leads the competition with time- and money-saving features! Built to handle your big jobs—fast!

- Exceptionally high copy quality
- Fast, delivers up to 55 copies per minute
- Automatic Computer Forms Feeder feeds unburst computer printouts
- State-of-the-art Page Programming adds good-looking covers, dividers and head-

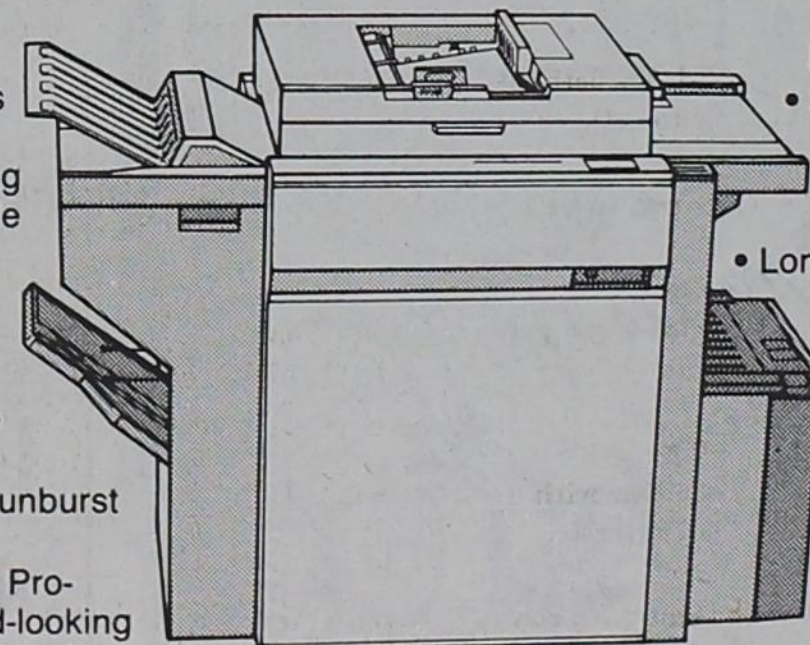

- ings automatically
- Selective Editing flexibility automatically deletes lines or paragraphs while copying
- Long-run Paper Supply (2720 sheets) gets every job done faster
- Variable Reduction/Enlargement (in 1% increments from 65% to 141%)
- With all the reliability you expect from Xerox!

Office Systems and Supply



101 Commerce Way
762-0679
Clovis



Farwell Convalescent Center
Chit Chat
By Lynne Gann
Activity Director

We have had caroling, Christmas parties, guests from long distances visiting, and in the midst of all the holiday season, we had a baby shower for Laurie Haddenhorst and Lupe Vidaurri. We, too, are trying to wait patiently for these new arrivals. Keep us informed, ladies, please.

Our Christmas party was a huge success. Many families are making friends with other residents and their families. A very happy celebration of Christ's birth was had by all.

All the residents and staff would like to extend our sincere wishes for a joyous holiday season to each and every one of you.

May peace and love be your closest friend for the coming year.

Meals on Wheels

Noon meals can be delivered to your door. For further information, contact the Farwell Convalescent Center at 481-9027. This program is for elderly, handicapped and temporary illnesses.

Tele-Care

To join our Tele-Care reassurance program created to provide a sense of security and protection, please call Linda Winegeart at 481-9027 weekdays from 8:30 - 5.

'Yield' to present free concert



Daniel Hutchins

The youth group of Hamlin Memorial United Methodist Church is presenting a free concert at the church on Dec. 30 at 8 p.m.

The concert will feature music by "Yield", a musical group from McMurray College which features Farwell graduate Daniel Hutchins.

Yield is composed of four people from McMurray College: Sam Walters, David Pomerincke, Tom McLeod, and Hutchins.

Hutchins is the son of Mr. and Mrs. Lee Hutchins. He graduated last spring from Farwell High. He is a freshman music major who is plays saxophone and keyboard.

Walters is a religion ma-

major from Springer, N.M., who plays guitar and sings. Pomerincke is a teacher who graduated from McMurray and plays guitar and does vocals. McLeod of Stevensville is a business major who plays bass and sings backup.

The concert features contemporary Christian music and word to provide a positive Christian witness. There will be no charge for the concert, but a free will offering will be collected.

Redwine scores 18

Lazbuddie girls defeated Morton JV 45-23 in the first game of the Lazbuddie tournament.

Lazbuddie's Redwine scored 18 points. Lazbuddie has an 8-4 record.

On Friday, Lazbuddie's girls defeated Bledsoe, 64-61. Scoring for Lazbuddie were: McGehee, 22; Redwine, 16; Jennings, 13; and Jesko, 11.

The Lazbuddie Longhorns defeated Morton J.V. 95-47. Scoring for Lazbuddie were: Glover, 25; Miller, 19; Zamora, 15, and Jarman, 12. Lazbuddie went into the tournament with a 7-6 record.

Lazbuddie was defeated by Plainview J.V. in their second game of the tourney, 58-47. Scoring leaders for Lazbuddie were Glover, 15, Zamora, 12, and Jarman, 11.

The Lazbuddie Longhorns participated in the Floyd, N.M., basketball tourney Dec. 10-12. The Longhorns won 1 and lost 2, while the Lady Horns won 2 and lost 1.

The girls lost to Fort Sumner, 45-36; and won over House, 56-44 and Floyd, 52-47 (in two overtimes).

Floyd was defeated after a bucket and 3 free throws by Jonessa Jennings in the final minutes of the second overtime. Amy McGehee made eight 3-point shots.

The boys lost to Floyd, 61-58, and San Jon, 68-64, but tipped Carrizozo, 60-59.

Top scorers for the tourney were: Jennings and McGehee, each with 38 points; Susan Redwine, 22; Amy Daniel, 17; Stacie Hodges, 14; Ginger Jesko, 8, and Britt Engelking,

6. The Lazbuddie girls placed 2nd in the tourney, and Jennings and McGehee were named to the All-Tournament team.

Boys' top scorers were: Brian Glover, 56 points; Wes Jarman, 37; Scott Miller, 28; Pat McBroom, 27; Eddie Zamora and Michael Williams, each with 11; Omar Sanchez, 9; and Kevin McGehee, 3. 3-point baskets were made by Glover, Jarman, Williams, Zamora and Sanchez.

Earlier, Lazbuddie teams played Shallowater Nov. 20.

The varsity boys won, 71-61. Top scorers were Glover, 24; Sanchez, 22, and Tim Lust, 10.

The varsity girls lost to Shallowater. Scoring were McGehee, 10; Jesko, 8, and Mia Jennings, 7.

On Nov. 24, Lazbuddie varsity boys' beat Springlake - Earth. Scoring were Glover, 28; Lust, 20, and Jarman, 9. The varsity girls lost by 6; scoring were Mia Jennings,

15; McGehee, 13, and Jesko, 10.

Reception reminder

The family of Bill and Bernice Dollar reminds their friends and family members of the reception in honor of the Dollar's 60th wedding anniversary Saturday from 2-5 p.m. at the Fellowship hall of the First Baptist Church in Farwell.



Glad to have been your little helpers in the past. Visit us again soon.

Merry Christmas from
Othena Smith & Pam Bernier

Smith Office Supply

Texico 482-9312 Friona 247-2411

Lutheran youth go caroling

The Lutheran Youth and Sunday School classes of St. John Lutheran Church went Christmas caroling on Dec. 20.

They sang at the Farwell Convalescent Center and the Muleshoe convalescent center and at the homes of some of the members. At the end of the evening, they had a party at the church.

On Dec. 23 they will decorate the church Christmas tree and prepare goodies.

On Dec. 24 they will have a Sunday School Christmas program at St. John's at 6 p.m.

Greetings

from all of us to all of you - Merry Christmas!

DOC STEWART
CHEVROLET BUICK, INC.

2500 MABRY
CLOVIS, N.M.

Texico

(Continued from Page 1)

decision on what to do with the old Texico depot. A group headed by Ann Cooper and David Kube have been busy raising funds and seeking a state grant to move this historical building. It's not known how long Santa Fe officials will wait.

The Texico City Council last month voted to apply for a state grant, at the group's urging. But councilmen still have questions involving the building if it turns out the grant is approved and the city gets control of it.

So the council Tuesday

voted to have City Attorney Duane Hamar check on the legality of donating the building to the depot group in that case.

In other business, the council:

- Decided to rewrite the personnel guidelines for the city marshal's post before advertising for a new marshal.
- Ordered 12 water meters.
- Agreed to buy a new car-buretor for the water department truck.
- Discussed a raise for the municipal judge.

Marriage Licenses

There were nine marriage licenses issued in Parmer County last week.

They were issued to: Noe Guerra and Maria Hernandez; James Clark and Rachel McMurtrey; Jeffery Martin and Helen Casenarez; Jesus Castaneda and Ana Contreras; Terry Rogers and Lela Crider; Ronald Dwire and Judith Roubison; Filberto Derma and Maria Galviz; Danny Finch and Kathy Falkenberg; Mark Stephenson and Kerry Winkelman.



Progressive dinner held

The youth group of the Hamlin Memorial United Methodist Church held a progressive dinner on Dec. 20.

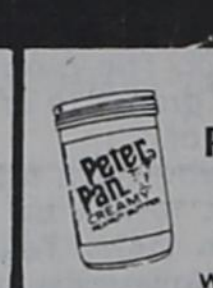

Following the dinner, they attended the service of Carols and Candles at the church.

Then the group sang carols at the homes of some of the shut-in members of the congregation. The evening ended with hot chocolate and cookies at the home of Mr. and Mrs. John Grigsby.

Your Christmas Savings Place!

 <p>Bonus Bucks 32-oz. reg. or lite MIRACLE WHIP 99¢ WITH ONE FILLED BONUS BUCK CARD 1</p>	 <p>Bonus Bucks Peter Pan 18-oz. PEANUT BUTTER 99¢ WITH ONE FILLED BONUS BUCK CARD 2</p>	<p>Bonus Bucks 48 daytime, 66 small, 27 ex. large HUGGIES \$8.94 WITH ONE FILLED BONUS BUCK CARD 3</p>
 <p>Bonus Bucks Hormel Big 12-oz. can SPAM 79¢ WITH ONE FILLED BONUS BUCK CARD 4</p>	<p>Bonus Bucks Shurfresh 1-lb. pkg. BACON 49¢ WITH ONE FILLED BONUS BUCK CARD 5</p>	<p>Bonus Bucks 150 count box PUFFS WITH LOTION 49¢ WITH ONE FILLED BONUS BUCK CARD 6</p>
<p>Bonus Bucks Pillsbury 2-lb. box Hungry Jack PANCAKE MIX 29¢ WITH ONE FILLED BONUS BUCK CARD 7</p>	 <p>Bonus Bucks Starkist 6 1/2 oz. Water, oil pack TUNA 9¢ WITH ONE FILLED BONUS BUCK CARD 8</p>	<p>Bonus Bucks Shurfresh Half Gallon BUTTERMILK 39¢ WITH ONE FILLED BONUS BUCK CARD 9</p>

<p>Farm Fresh Grain Fed \$ 1.98 WHOLE CATFISH Lb.</p> <hr/> <p>Lean Boneless \$ 1.89 SIRLOIN STEAK Lb.</p> <hr/> <p>Peyton's Market Sliced 98¢ BOLOGNA Lb.</p>	<p>Kraft Market Sliced \$ 1.89 AMERICAN CHEESE Lb.</p> <hr/> <p>8-10 chops SLICED 1/4 \$ 1.39 PORK LOIN Lb.</p> <p style="text-align: center;"><i>Prices effective Dec. 26 - Dec. 30</i></p>
--	---

50-oz. box FINISH \$2.19	Pace Big 24-oz. PICANTE SAUCE \$1.69	Schilling 12 1/2-oz. TACO CASSEROLE \$1.49	Giant Size TIDE \$1.79
2-Liter Reg. or Diet COCA COLA  89¢	Popsite 2-lb. bag POPCORN 69¢	Shurfine 1-lb. box CRACKERS 59¢	2.49 size bag RUFFLES  \$ 1.79
Price Saver 42-oz. can SHORTENING \$ 1.09	Casserole 2-lb. bag PINTO BEANS 59¢	Lawry 10-count TACO SHELLS 79¢	Folger's 1-lb. can COFFEE \$ 2.49 
Shurfresh Grade A LARGE EGGS 69¢	Best Maid 24-oz. jar Kosher Dill SPEARS \$1.19	Hunt's 8-oz. TOMATO SAUCE 4/\$1	
Hormel 15-oz. can Reg or Hot TAMALES 69¢	Wolf 19-oz. can (No Beans) CHILI \$1.19	Campbell's No. 1 can Chicken Noodle SOUP 2/79¢	

GARDEN FRESH PRODUCE		FROZEN FOODS	
Colo. U.S. 1 10-lb. bag RUSSET POTATOES \$ 1.19	Texas firm head CABBAGE 9¢ lb.	Patio 16-oz. 2 beef, 2 cheese ENCHILADAS \$1.29	
Hass Jumbo AVOCADOS 3/\$1	Golden ripe BANANAS 25¢ lb.	Citrus Hills 12-oz. can ORANGE JUICE 99¢	Patio 5-oz. asstd. BURRITOS 3/\$1



Capitol Foods

900 Ave. A - Farwell - Ph. 481-3432

We Redeem U.S.A. Food Stamps Open til 9 o'clock Every Night



TALENT

Texico Farwell has it

And more
on Page 2...

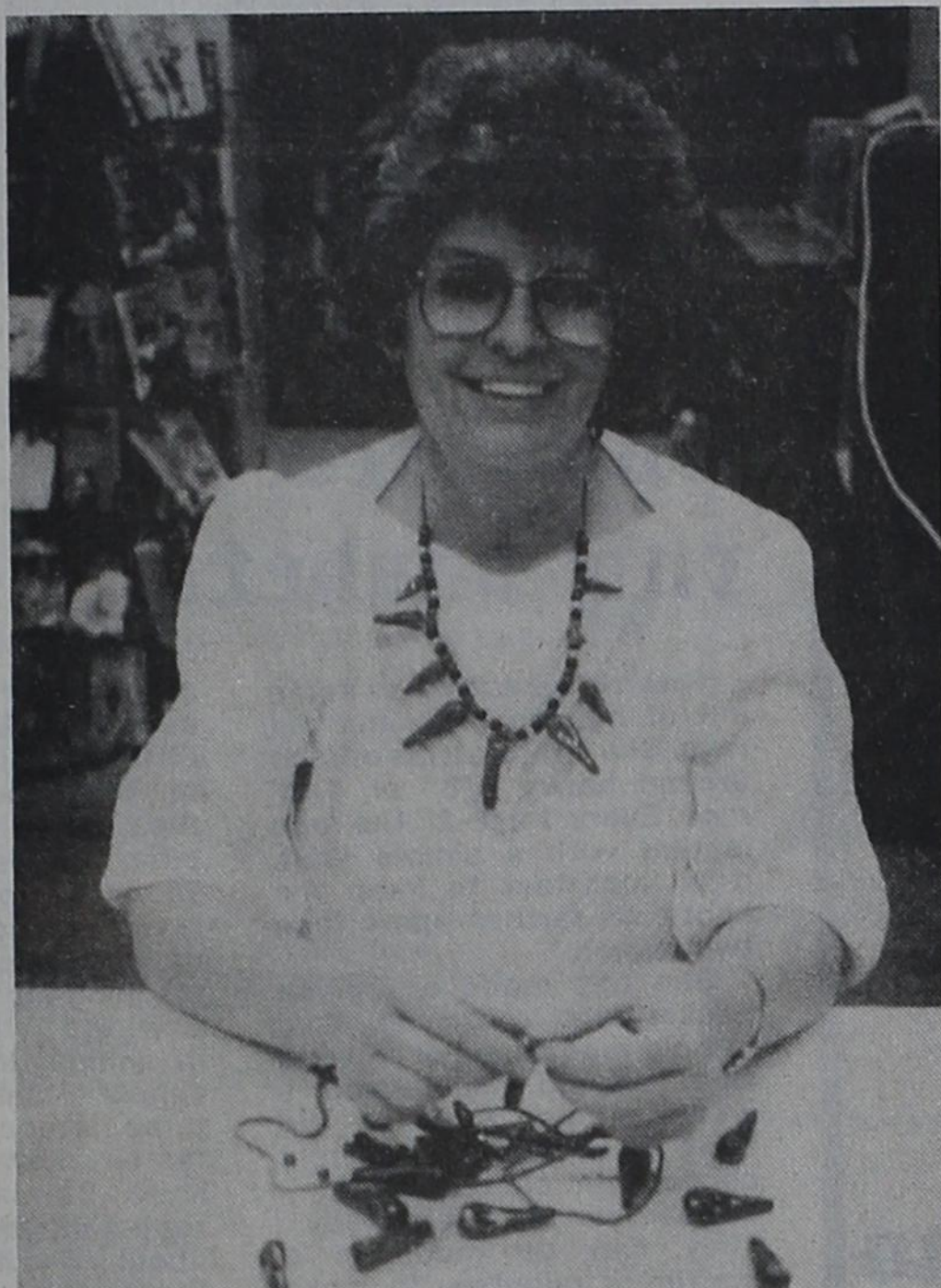

Billie Cooper

Chili pepper necklaces

Texico art teacher and librarian, Billie Cooper, made chili pepper necklaces for special people on her list. She strings pony beads and bright red artificial chili peppers onto leather cords to make the necklaces.

She buys the chili peppers in three sizes. The smallest ones make perfect drop earrings. The medium and large sizes are used on the necklaces.

Mrs. Cooper's art classes made some interesting gifts and decorations for Christmas, too. The students made Christmas tree ornaments to decorate the school library.

One project involved making ornaments from pre-molded egg-shaped ceramic bases. Indian designs, beads,

and pheasant feathers were added to give the ornaments a uniquely Southwestern look.

"I feel that the students need some experience learning the techniques of ceramics and design before I can say, 'Go make an original ornament.' So, we start with examples that have been made up in advance. Later on, after they have mastered the techniques, they can design their own."

Another project that Mrs. Cooper's classes made are Christmas ornaments made from red cartwheel beads strung on pipestem cleaners to look like chili peppers.

Some of Mrs. Cooper's students made ceramic partridges decorated with Indian designs and Southwestern designs.



Janie Bowery

Crocheting

Janie Bowery, Farwell's City Clerk for the past 25 years, looks forward to the time when she can devote her full time to her arts and crafts. She will retire from the city job Dec. 31.

Mrs. Bowery quilts bed spreads, and she makes crocheted items.

She crochets miniature caps which can be used as ornaments or as pot lid lifters. She also adds crocheted trim to tea towels. The crocheted area acts as a handle which can be fastened to a cabinet drawer or a refrigerator handle.

Punch needle

Jean Travis will make several of her Christmas gifts with punch needle embroidery. She also paints sweat-shirts.

"It takes me about 8 hours to do a sweatshirt with punch needle embroidery. There is only one stitch to learn, and it goes pretty fast," she says.

A design is stamped onto fabric, and the person doing the needlework fills in the spaces by following a color coded key.

The needle makes looped stitches which can be left as they are, or cut and brushed to make a hair-like texture.

One common error made

by beginners at punch needle embroidery is to put too many stitches close together. It is important to leave a space between stitches.

Mrs. Travis also recommends that a woven interfacing be used so that the design does not slip each time the fabric moves.

"I got into this when I had foot surgery. My son and daughter-in-law sent me a kit, and I started enjoying it." When Mrs. Travis showed the work to some of her friends they liked it, too. So, she began selling the kits.

"It is the easiest type of embroidery I've ever done," she says.



Jean Travis is shown with her punch needle embroidery.

Ceramic projects

About 25 local senior citizens work on ceramic projects at the Texico-Farwell Senior Citizens Center.

They purchase the greenware (unfinished ceramics) where they want to, and bring it to the Senior Citizens Center where Maureen Caywood helps them complete the projects.

First the raw, unfired clay piece must be cleaned. Little bits of rough clay must be scraped off and smoothed down. The object is to make the piece as smooth as possible.

"Everyone breaks a piece during cleaning at least once," says Mrs. Caywood.

When the ceramic piece is cooled, a finish is applied. The colors often look quite different from the finished color. "Some of the unheated colors look just the opposite of what they will look like when they are heated. The green paint looks red when

it is applied," said Mrs. Caywood.

After the coloring is applied, the piece is fired in a kiln which is slowly heated to a very high temperature. This hardens the greenware and changes the color of the finish.

When the piece has completely cooled, a glaze or finish is painted on, and the piece may be fired again.

"Most pieces need at least two firings," says Mrs. Caywood.

The senior citizens pay \$1.25 each time they come to the center to work on their projects. Mrs. Caywood fires the pieces and has glazes and stains available for their use.

"We have some ladies who come in the afternoon, and some who come in the evening. Sometimes a younger family member will join in to the class if they are waiting to drive a senior citizen home," says Mrs. Caywood.

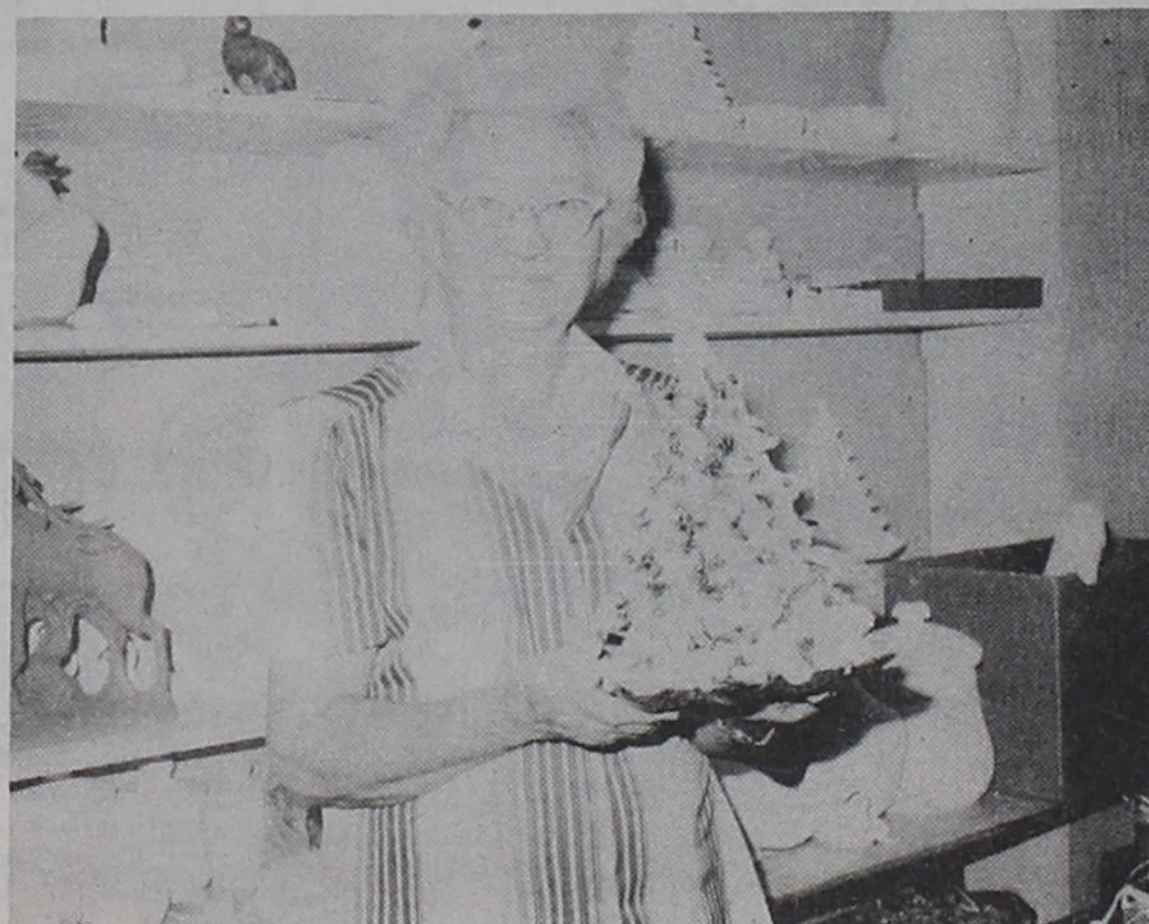

Maureen Caywood shows some of the ceramic work done at the Texico-Farwell Senior Citizens Center.



Eunice Crume does needle-work as well as painting for her Christmas gifts.

Painting, needle work

Eunice Crume is best known locally for her painting talents. She has painted several landscapes that adorn her home. Mrs. Crume has taken classes under Mrs. Gregory in Clovis and Mrs. Magness in Farwell.

Mrs. Crume also enjoys needle work of many different types. She is shown holding a goose adorned with a big bow and candlewicking stitches. On her lap is an afghan she crocheted, and a needlepoint tissue box that she made. On the arm of the chair is a crocheted lace collar and a cross stitch pillow she made. Some of these items will be found under the Christmas trees of Mrs. Crume's loved ones.

Crafts



Miniature decorations

Kendale Burch, home economics teacher at Texico, makes miniature rolling pin decorations for special people on her Christmas list. She makes the rolling pins out of dowels (about 1 1/2"-2" in diameter with pieces of 1/4" dowel attached to either end as handles). Then she cross stitches sayings onto fabric and covers the rolling pins. Ribbon or lace finish the decorations.



Gwen Hughes makes rag baskets for Christmas.

Coasters, rag baskets

Gwen Hughes makes items out of manilla rope and old rags. She wraps strips of rags around heavy 3/8" or 1/2" rope. Every 1 1/2"-2" the rope is tied with a simple knot. It is important to keep the knots no farther apart than two inches.

She has made a fireside basket which can be used to hold magazines or flowers from an old sheet, and a water pitcher from an old table cloth, and a casserole carrier from old remnants.

Coasters are really easy. They can be made in a matter of minutes. To make a simple coaster, cut fabric into strips about 1 1/2" wide. Unwind one end of the rope

a couple of inches, and cut each strand of the rope a different height. Wrap the end of the rope with masking tape. It will now look pointed. Wrap the fabric away from yourself around the end of the rope about three inches; cover the end so that the masking tape does not show. Coil the end of the rope in against itself. Tie with a simple T shaped knot. Wrap three wraps of fabric, and fasten with another T shaped knot. Continue coiling the rope until you have a coaster about 3-4" in diameter. Fasten the end securely.

There are craft magazines available to show the basic knot and to give directions for more difficult projects.

Santa's bringing you our warmest wishes for a very Happy Holiday, filled with love and good cheer.

We have enjoyed serving you and look forward to seeing you next year.



MERRY CHRISTMAS



EXCEL

CORPORATION
FRIONA
DIVISION

FROM
EVERYONE AT:

German crescent rolls sound yummy

Pat Rose kindly loaned The Tribune her grandmother's first cookbook which looks like it was written about the turn of the century.

Some of these recipes sound as good today as they did years ago, even if the directions are a little unusual. Kreusnach Horns (German Crescent Rolls)

- 4 c. flour
- 1 yeast cake
- 2 Tbs. sugar
- 2 eggs
- 1/3 c. water
- 1 c. milk
- 1/2 tsp. salt

Mix 2 c. flour with the yeast cake and milk. When it rises, make into a dough with the rest of the flour, adding the butter, sugar, eggs, and salt. Let it rise again. Roll it out into pieces six inches square and quite thin. Cut each square into four triangles, brush with melted butter, dust lightly with flour. Roll up starting from the wide side letting part of the point of the triangle come on top. Bend around in the form of a horseshoe for crescent shaped rolls.

Put them to rise in a greased pan when ready to bake, brush over with milk, and bake in a hot oven (400 degrees) until brown.

Everton Taffy

- 1 1/2 lbs. sugar
- 3 1/2 oz. butter
- 1 1/4 c. water
- juice of one lemon
- grated peel of 1/2 lemon

Boil all the ingredients together except the lemon juice over a hot stove stirring constantly. Continue cooking until the mixture becomes hard and brittle when dropped into cold water. Remove from the fire. Stir in the lemon juice and pour into buttered pans to cool.

When the mixture is cool enough to handle, pull the taffy until it is a smooth, light color. Draw out on waxed paper, and cut with scissors.

Little Date Nut Loaves

- 2 eggs
- 2/3 c. milk
- 2 pkg. Martha White Bran Muffin Mix
- 1 c. chopped dates
- 1 c. chopped pecans

Preheat oven to 350°F. Grease 5 miniature loaf pans (4 1/2 x 2 1/2 x 1 1/2 inches). Beat eggs in mixing bowl. Add remaining ingredients and stir just until blended. Divide batter among prepared pans.

Bake 30-35 min. or until toothpick comes out clean. Makes 5 miniature loaves.

Basic Sugar Cookie Dough

- 1 c. soft butter
- 1 1/2 c. confectioner's sugar
- 1 egg
- 1 tsp. vanilla
- 2 1/2 c. flour

Meet Farwell's Class of 2000



April Kelley was born on Dec. 17. She is in Mrs. Dyer's class. April is the daughter of Randy and Carla Kelley. Her brothers are Blake and Clint, and her sister is Kayla. April's grandparents are Carl and Evelyn Ellington and E.C. and Jennie Kelley.

April likes catching butterflies, coloring, going to kindergarten, making friends, shopping, and going on trips and staying in motels.

Her pet dog is named Maggie.

Sponsored by 5 Area Telephone Cooperative
Serving our customers in Lazbuddie and Lariat

1 tsp. baking soda
1 tsp. cream of tartar
In a large bowl, mix butter, sugar, egg and vanilla. Blend in remaining ingredients on low speed to make a soft dough, scraping bowl constantly.

variation # one: Add 1/2 cup of your favorite hard candy, crushed. Work candy into dough. Add a few drops of food coloring if desired. Chill dough for 1-2 hours. Bake in 375° oven 6-8 min. Brush the tops of cooled cookies with corn syrup. Sprinkle with decorators' sugar.

variation # two: Heat oven to 425°. Spread cookie dough evenly in two pans 13x9x2. Bake 10 min. Cool. Cover cooled cookies with prepared frosting chopped nuts. Cut into small squares.

Quick Oatmeal Cookies for those times when the kids say "I forgot to tell you, but I need to bring some cookies."

- 1/2 c. margarine
- 1/2 c. milk
- 2 c. sugar
- 1 tsp. vanilla

- 3 c. quick oats
- 6 oz. chocolate chips
- 1/2 c. nuts
- 1/2 c. coconut

Bring margarine, milk, sugar, and vanilla to a boil. Add oats, chocolate chips, nuts, and coconuts. Mix well.

Drop by a teaspoon onto a cookie sheet. Ready in 15 minutes. No baking.

Butter mint Cookies

- 1 c. butter
- 1 c. butter mints crushed
- 2 c. flour
- 1 T. sugar
- 1/4 t. salt

Cream butter. Add crushed mints. Add flour and salt. Blend well. Pat into a 9" square.

Cut into 1 1/2" squares. Sprinkle with sugar. Bake on ungreased cookie sheets at 300 degrees for 18-20 minutes until pale golden brown. Do not overbake. Makes 36.

Clovis Shopping Guide

- Custom Framing •
- Art Supplies • • Frames •
- Designer Mats •



FRAME & ART

Sharlene Lynch

Owner

Member PPFA

1713 W. 21st, Clovis

505/763-5714

"Where you find the gifts they love"



Bud & Phyllis Queener 311 Main Street
Phone (505) 762-1691 Clovis, N.M. 88101

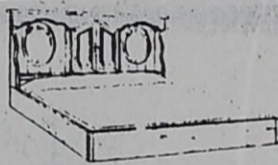

SHOP QUALITY AND VALUE

Prince Furniture Waterbeds
Waterbeds Accessories Phone 762-0892
1511 N. Prince Street • Clovis



Medco Medical
EQUIPMENT & SUPPLY

- COLOSTOMY SUPPLIES
- WHEELCHAIRS
- HOSPITAL BEDS
- BEDSIDE UTENSILS
- TRAPEZE BARS
- TRACTION EQUIPMENT
- I P P B EQUIPMENT
- OXYGEN EQUIPMENT
- COMMUNE CHAIRS
- INCONTINENT SUPPLIES
- BED PADS
- DISPOSABLE PADS
- PATIENT LIFTS
- WALKERS

SALES • RENTALS • REPAIRS

Medco Medical
121 W. 5th
Clovis, NM 88101
505-762-2964

Medicare approved
Licensed technicians

Everything You Need For The Home in Medical Care & Supplies!
Mon. - Fri. 9 - 5
24-Hour
Emergency Service

Misses 6 - 18

Juniors 3 - 15

Queens n' Teens

500 Main, Clovis - (505) 763-7153



"Where Life Begins in Style"

Maternity Wear
Infant's Wear
Nursery Accessories
Gifts

Mon. - Sat.
9:00 AM - 5:30 PM

Dorothy & Jim Reid
Owners

(505) 762-0962



Clovis Furniture Center

NEW & USED FURNITURE
BUY, SELL & TRADE

DON & ORA KRAUS

101 PILE
CLOVIS, NM 88101

ASSOCIATED COMMUNICATIONS, INC. Mobile Phones & 2-Way Radios

116 East Grand Street
Clovis, New Mexico 88101
(505) 763-5520

MOBILE COMMUNICATIONS
AUTHORIZED DEALER

Carol Nichols
Sales Manager

Wayne Walls
Sales

Furrow's Home Lumber, Inc.

All Your Building Needs

- | | | |
|------------|--------------------|----------|
| Paint | Stucco & Cement | Lumber |
| Hardware | Windows & Doors | Siding |
| Insulation | Moulding & Trim | Fencing |
| Plywood | Shingles & Roofing | Paneling |

1201 E. 1st St.
Clovis, NM 88101
(505) 763-4437

Store Hours:
7 - 5 Mon. - Fri.
7 - 12 Sat.



Bridal Registry,
Linens & Gifts

Bright Ideas



2400 N. Prince
762-1117

Sue Patterson, owner

WE TRADE AND SELL PAPERBACK BOOKS
GIFTS FOR ALL OCCASIONS
GAG GIFT HEADQUARTERS

VHS movie rentals (7 days a week) 99¢

Talico Gift Shop & Book Exchange

1301 N PRINCE CLOVIS

PHONE (505) 763-7720

DON'T GET CAUGHT....



Trees,
Bushes,
& Hedges
Trimmed
& Shaped

OUT ON A LIMB
SHOT'S TREE TRIMMING
WILL DO IT RIGHT

FREE ESTIMATES 762-0060

THE SHOE STRING



Consignment On Nice Clothes & Accessories
New Indian Jewelry & Gifts

919 Main
Clovis, N.M. 88101

Store Hours
9 to 5 Tuesday thru Saturday
762-5210



International Tours® of Clovis

Complete
Business &
Pleasure Travel Services

501 Commerce Way,
Suite 6
Clovis, New Mexico 88101

(505) 763-3486

Tuesday through Saturday



ERONICA'S
Shear Magic

early and late appointments

Free hair styling

consultations

762-7657

106 W. 5th

Hair designed with YOU in mind

Yuletide Greetings! May home and hearts be filled with laughter, joy and good will this glad Holiday Season.

Peggy and Chris
Dorothy and June



Twin Oaks
PSI DESIGNS



410 THIRD STREET

FARWELL 806/481-3864

'I'd like a gun that shoots fire'

Dear Santa,
I hope you are doing fine. I am eight years old. My name is Bruntn Embry. I want a 10-speed Street Runner 20" bike.
Bruntn Embry

Dear Santa Claus,
How are you? I have a broken arm so I can't write very well for Christmas, I would like a Pleasant Company Doll, Kirsten. I would also like a watch, and a brass doll cradle. I would enjoy these items very much. I would enjoy the Kirsten doll the best. I just said that so you will know you are nice.
Love,
Rachel Embry
P.S. I would like a hand watch. I do not like digital. Thank you. And I forgot to write that I would like a rock tumbler.

Dear Santa,
Please bring me a cowboy hat, some Minnie Mouse snow boots, and Barbie clothes. Bring my little brother a new football. I can hardly wait for you to come. Thank you!
Love,
Kayla Elliott
Age 4
Lazbuddie Kindergarten

Dear Santa,
Please bring me a combine, a helicopter, and a tractor. Bring Filemon, a robot; Rachael a Cabbage Patch; Lucinda a Care Bear; Mommy another oven, and Daddy some books. I have been good this year.
Thank you,
Fabian Guzman
Age 5
Lazbuddie Kindergarten

Dear Santa, Please bring me a new bicycle and a Popple. I would like my mommy to have a baby-lok sewing machine and a new pair of boots for my daddy.
Thank You.
Love,
Jennifer Brumfield
Age 5
Lazbuddie Kindergarten

Dear Santa,
Please send me a hammock with buttons, a gun that shoots pretend fire, and a fire suit, and a Sesame Street talking story computer.
Please bring my brother a box house, new clothes for mommy, and some new cows for daddy. Thank you.

Tye Freeman
Age 5
Lazbuddie Kindergarten

Dear Santa,
Please bring me some cowboy stuff, a My Pet Monster with a break away chain, and a jet. Bring my sister Dawnda a new

Barbie, and a Barbie house for Mandy. My little brother Eric wants He Man figures. Bring clothes to mommy and some tools for daddy.
Thank you and Merry Christmas,
Garrett Magby
Age 6
Lazbuddie Kindergarten

Dear Santa,
Please bring a My Pet Monster, a tractor, an airplane, a Big Foot, and a four wheeler. Bring my sister Christina a Barbie, flowers for mommy, and a gun for daddy.
Thank you. Love,
Bobby Martha
Age 5
Lazbuddie Kindergarten

Dear Santa,
Please bring me a four wheeler, money, and one more thing, a book, and that's all. Also bring something nice to the rest of my brothers and sisters and mom and dad.
Thank you,
Billy Martinez
Age 5
Lazbuddie Kindergarten

Please bring me some snow boots, a big combine, two cars, and that's all. Please bring my sister Candice a Barbie for Christmas, and a baby with a bottle. Bring a billfold for daddy and a billfold for mommy, too.
Thank you, Love,
Brandon Randolph
Age 6
Lazbuddie Kindergarten

Dear Santa,
Please bring a tractor, a power wheels jeep, a jack-in-the-box, and a fun Playdoh set, and the two children Popples. Bring Mommy a dress and Daddy some new gray pants. Please bring my brother Jeff a new shirt and shorts. Sherry wants a dress to wear on Christmas Eve.
Thank you, Love,
Jason Jesko
Age 5
Lazbuddie Kindergarten

Dear Santa,
Please bring me a back pack, some cowboys and Indians, and

a green tree. Bring something nice for my brothers and sisters, and mother and daddy.
Thank you. Love,
Gabriel Reyes,
Age 5
Lazbuddie Kindergarten

Dear Santa, Please bring me a play black billfold, and money, visa card, driver's license, Thundercat, and He-Man stuff, and that's all. I've tried to be real good this year. Thank you.
Love,
Jeffrey Seaton
Age 5
Lazbuddie Kindergarten

Dear Santa,
Hi. Please bring me a fluffy kitten and a doll house. Send my brother Heath a Super Mario Brothers, a blue jean dress for mother, and some new tools for daddy.
Thank you.
Scottie Brown,
Age 6
Lazbuddie Kindergarten

Dear Santa,
Hi. Please send me a little Popple and a big Popple. And I want a little car with doors and a Toy factory. Send my sister Shana a book with pictures, a skirt for mother, and a coat for daddy.
Thank you,
Staci Foster,
Age 5
Lazbuddie Kindergarten

Dear Santa,
Please send me a doll that talks, play dishes, and a Barbie doll and something nice for the rest of my family.
Thank you,
Veronica Gutierrez
Age 5
Lazbuddie Kindergarten

Dear Santa,
Hi Please send me a Barbie and a Barbie house, a coloring book and a purple heart. Send my brother, Jose, a CareBear, and a bear for Jr. A watch for my mother and a nice hat for my daddy.
Thank you,
Zulema Marquez
Age 6

Dear Santa,
Please send me a pretty dress, colors, a coloring book, shoes, and a ball. Send my sister Rebecca a pair of pants and some cowboy things, and send a pair of little shoes for by brother Raul. Please bring a dress for Mommy and pants and shoes for Daddy.
Thank you,
Veronica Mata
Age 6
Lazbuddie Kindergarten

Dear Santa,
Hi. Please bring me a doll that talks, lots of candy and clothers. Send my sister, Anavel, a doll that talks; clothes for my sister, Blanca; a pair of tennis shoes for my brother, Aaron; a tractor for my brother, Jaime, and candies and clothes for my sister, Norma. Please bring some nice dishes for Mother and a gun for Daddy.
Thank you,
Liset Solis
Age 6
Lazbuddie Kindergarten

Dear Santa,
Please bring me a gun that shoots fire, a back pack, a play monster, and a watch and a camera. Bring Levi a book and Cami a Barbie with icecream stand. Bring Mommy new clothes and Daddy a brand new hat.
Thank you.
Love,
Christopher Vaughn,
Age 5
Lazbuddie Kindergarten

Dear Santa, Hi. Please send

me a tractor, combine, and a truck. Send my brother, Julian, a car, a kitty for my mother and a nice clock for daddy.
Thank you.
Domingo Chavez
Age 5
Lazbuddie Kindergarten

Dear Santa,
Please bring me two Barbies with dresses, a watch, and a Barbie doll house. My sister wants a Mickey Mouse telephone. My mom wants a dress and a suit for my daddy. That's all. Thank you.
Love,

Trudy Valencia
Age 6
Lazbuddie Kindergarten

Dear Santa,
Please bring me a Barbie that makes ice cream, a purse filled with keys, money, and stuff. Bring my sister blocks to play with. My mother needs a purse and bring daddy some socks to keep his feet warm.

Thank you,
Carolina Rivera
Age 5
Lazbuddie

FRIDAY

ON CABLE
A MAN FOR
ALL SEASONS



Spend your Holiday with Ralph Emery and his celebrity guests on NASHVILLE NOW CHRISTMAS '87. Only on The Nashville Network

Friday, 6 p.m. CST

Channel 20



COOKE CABLEVISION INC

Ph. 763-4411

Christmas JOY

... and much happiness to
all our good friends.

The Texico
Post Office

Weldon Smith
Rada Winkles
Paul Skaggs
John Hadley
Bea Stone
Thelma Landsperg
Alice Pierce
Diane Smith



Greetings

To our patrons who've made our year extra special, may we wish you happiness and fulfillment this Christmas and in the days to follow. Our warmest greetings and thanks to you all.



West Texas
Rural Telephone
Cooperative

PLEASE ATTEND CHURCH SERVICES		
<p style="text-align: center;">Farwell First Baptist Church</p> <p>Sunday School - 9:45 a.m. Worship - 11 a.m. & 7 p.m.</p>	<p style="text-align: center;">Texico Assembly of God Church</p> <p>Sunday School - 9:15 a.m. MDT Worship - 10:15 a.m. & 6 p.m. MDT Wednesday - 7 p.m. MDT</p>	<p style="text-align: center;">Farwell Church Of Christ</p> <p>Bro. Virgil Fiske Bible Class - Sunday, 10 a.m. Worship - 10:50 a.m. & 6 p.m. Wednesday - 7:30 p.m.</p>
<p style="text-align: center;">San Jose Catholic Church Texico</p> <p>Fr. Godfrey Blank Sunday Mass - 9 a.m. MDT Wednesday - 7 p.m. MDT Confessions Before & After Mass</p>	<p style="text-align: center;">Hamlin Memorial United Methodist Church</p> <p>Rev. Steve Stephens Sunday School - 10 a.m. Worship - 11 a.m. Monday Prayer Breakfast - 7 a.m.</p>	<p style="text-align: center;">Texico First Baptist Church</p> <p>Rev. Joel Horne Sunday School - 9:30 a.m. MDT Worship 10:45 a.m. & 6:30 p.m. MDT Wednesday - 6:30 MDT; 7:00 MDT</p>
<p style="text-align: center;">St. John's Lutheran Church Lariat</p> <p>Rev. Mac Bearss Sunday School - 9:30 a.m. Worship - 10:30 a.m.</p>	<p style="text-align: center;">United Pentecostal Church Texico</p> <p>Pastor Raymond Parks Sunday School - 9 a.m. MST Worship - 10:15 a.m. & 6 p.m. MST Wednesday - 6:30 p.m. MST Thursday - 6:30 p.m. MST</p>	<p style="text-align: center;">Good Will Spanish Mission</p> <p>Pastor - Frank Ancira Sunday School - 9:30 a.m. MST Worship - 10:45 a.m. MST Training Union - 5:30 p.m. MST Worship - 6:30 p.m. MST</p>
<p style="text-align: center;">New Light Baptist Church</p> <p>Pastor - Thomas Spikes Sunday School - 9:45 a.m. Worship - 11 a.m. & 6:30 p.m. Bible study, 7:30 p.m. Wednesday - 7:30 p.m.</p>	<p style="text-align: center;">Pleasant Hill Baptist Church</p> <p>Rev. Gary Warren Sunday School - 9:30 a.m. MST Worship - 10:30 a.m. & 6:30 p.m. Church Training - 5:30 p.m. MST Wednesday - 6:30 p.m. MST</p>	<p style="text-align: center;">Oklahoma Lane Methodist Church</p> <p>Rev. Jeff Taylor Worship Service - 9 a.m. Sunday School - 10 a.m.</p>
<p style="text-align: center;">Lariat Church Of Christ</p> <p>Sam Billingsley - Minister Sunday School - 10 a.m. Worship - 10:45 a.m. & 6 p.m. Wednesday - 7:30 p.m. Winter Summer 8:30 p.m.</p>	<p style="text-align: center;">Calvary Missionary Baptist Church Farwell</p> <p>Bro. Paul Clevenger, Pastor Bro. Bob Talley, Associate Pastor Sunday School - 10 a.m. Worship - 11 a.m. & 6 p.m. Wednesday - 7 p.m.</p>	<p style="text-align: center;">Temple Baptist Church</p> <p>Sunday School - 10 a.m. Worship - 11 a.m. & 6 p.m. Wednesday - 7 p.m.</p>

Sponsoring this church listing are:

Farmers Cooperative Elevator - Muleshoe	Lovelace Oil
Five Area Telephone Cooperative	Farwell Insurance
Sherley-Anderson-Pitman	Kelly Green Seeds
West Texas Rural Telephone Cooperative	
Capitol Food	Twin Oaks Psi Design



FDIC

Member

Bill Christian Richard Hadley Kerwa Akers Gene Herwigler
 Fern Tharp Loretta Gargales Lisa Pena

Texica Branch



*Best Wishes
 for Christmas*

Celebrate His Birth

And the angel said:
 "... I bring you good news
 of a great joy which will come
 to all the people; for to you
 is born this day in the city of
 David a Savior, who is
 Christ the Lord."
 LUKE 2, 10-11

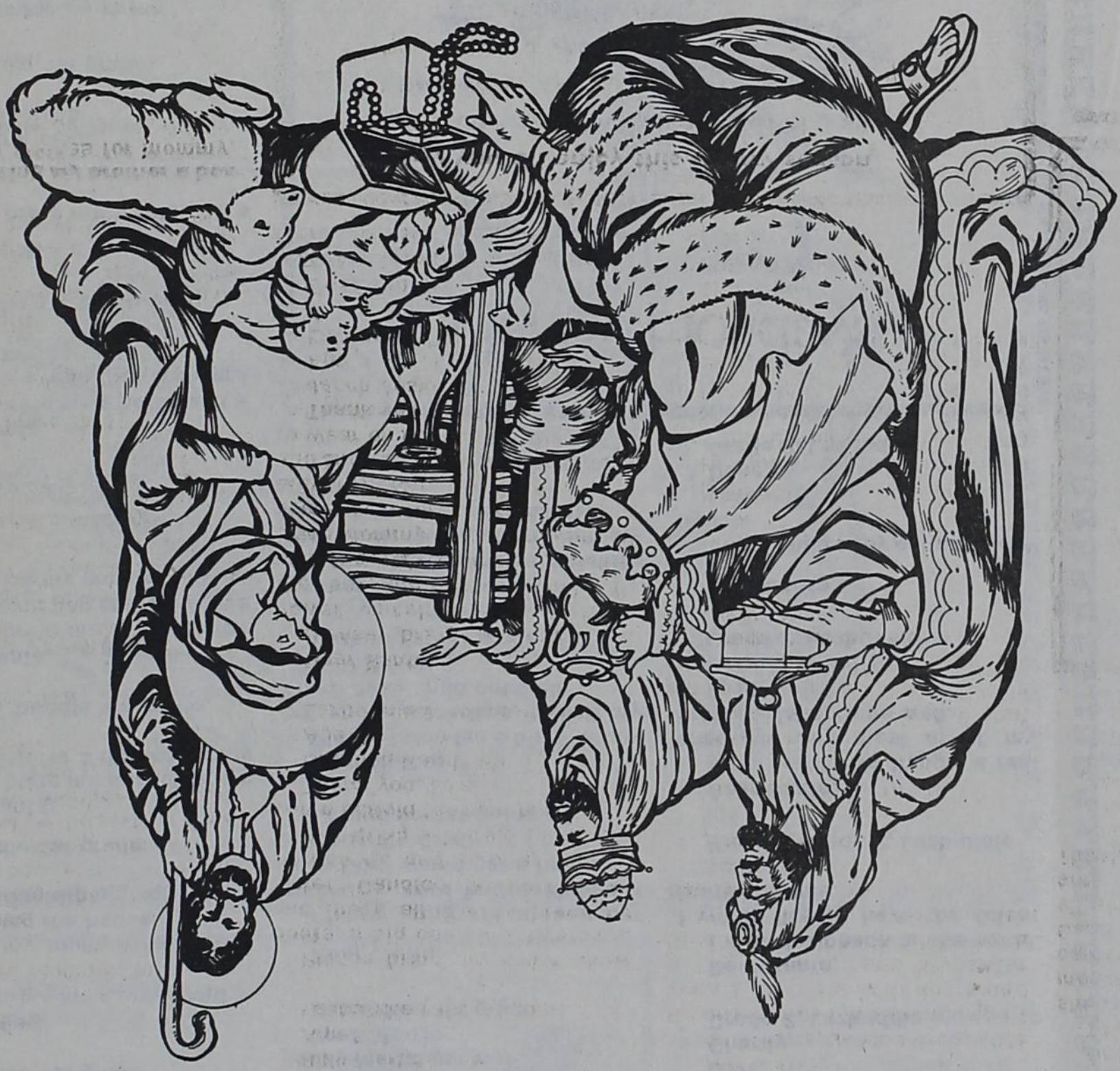

**Wish
 MERRY**

'I wish my mom could get well'

Dear Santa,
Please bring me a trampoline and a 22. I wish my dad would get finished stripping cotton.
Joshua McDonald
Age 6
Lazbuddie 1st grade

Dear Santa,
Please bring me a race car that digs in the sand and a basketball goal. I wish my daddy would get well.
Kevin Autry,
Age 6
Lazbuddie 1st grade

Dear Santa,
Please bring me a teddy bear and a toy horse. I wish my mom could have some jewelry.
Sherry Willis
Lazbuddie 1st grade

Dear Santa,
Please bring me a Barbie doll and play dishes.
I wish I could help my mom and dad.
Rosie Marruto,
Age 7
Lazbuddie 1st grade

Dear Santa,
Please bring me a purse and a doll.
I wish my mom would have help cleaning the house.
Christina Martha,
Age 6
Lazbuddie 1st grade

Dear Santa,
Please bring me a truck and a bike. I wish for a ddress for my nana.
Rick Lazbuddie 1st grade

Dear Santa,
Please bring me a Winnie the Pooh sleeping bag and a doll in a cradle. I wish my mom would get jewelry.
Holly,
Age 6
Lazbuddie 1st grade

Dear Santa,
Please bring me a horse and a new saddle. I wish that grandma would get better.
Amber,
Lazbuddie 1st grade

Dear Santa,
Please bring me a doll and a bracelet.
I wish my mom and dad could get an alarm clock.
Ysela Cuervas
Age 6
Lazbuddie 1st grade

Dear Santa,
Please bring me a telescope. I wish that my great-great grandmother would get better.
Code Morris
Age 7
Lazbuddie 1st grade

Dear Santa,
Please bring me Fival. I wish that mom would get well.
Kia Morris,
Lazbuddie 1st grade

Dear Santa,
Please bring me a coloring book, new colors and Barbie clothes. I wish for a doll for my sister.
Erika Rivera
Age 7
Lazbuddie 1st grade

Dear Santa,
Please bring me a jet and a dinosaur. I wish my sister would

get a canopy bed.
Jacoby Jennings
Age 7
Lazbuddie 1st grade

Dear Santa,
Please bring me a basketball and a football. I wish my grandpa would get better.
Kyle Autry
Age 6
Lazbuddie 1st grade

Dear Santa,
Please bring me a makeup kit and a Cabbage Patch doll. I wish my mom could get well.
Luz Cuervas
Lazbuddie 1st grade

Dear Santa,
Please bring me a Bouncy Curl Dragon Splashin kid doll. I wish for boots for mom and a bike for dad.
Shena Seaton,
Lazbuddie 1st grade

Dear Santa,
Please bring me a helicopter walkie talkie. I wish that the sick people could get well.
Josh Morris
Lazbuddie 1st grade

Dear Santa,
Please bring me a race car without a cord and a saddle. I wish Cory would get a horse.
Cody Winders
Lazbuddie 1st grade

Dear Santa,
Please bring me a black straw hat and a telescope. I wish my grand dad would get well.
Seth Black
Lazbuddie 1st grade

Dear Santa,
Please bring me a Baby Heather and a suit like yours. I wish my dog would have more babies.
Becky C.
Lazbuddie 1st grade

Dear Santa,
Please bring me a race track and a puppy. I wish my sister had a horse.
Johnny Willingham
Lazbuddie 1st grade

Dear Santa,
I want some horses. I want a skateboard.
Love,
Deon
Grade 2, Lazbuddie

Dear Santa,
I want a gun and a tree.
Love,
Jr.
Grade 2, Lazbuddie

Dear Santa,
I want a bike and a doll. That's all.
Love,
Crystal
Grade 2, Lazbuddie

Dear Santa,
I wish I could have a piano. I wish Mrs. Smith a Merry Christmas.
Love,
Charity
Grade 2, Lazbuddie

Dear Santa,
I wish for peace in the world. I would like to have the Ghost Busster home.
Love,
Brice F. Grade 2, Lazbuddie

Dear Santa,
I just want two things, a real shot gun and most of all my brother, John, to be well.
Love,
Gary
Grade 2, Lazbuddie

Dear Santa,
I wish I had a toy cat and a doll house.
Love,
Dene
Grade 2, Lazbuddie

Dear Santa,
I would like to have a football helmet. I wish I could have an NFL football. I wish I could have a computer.
Love,
Rusty
Grade 2, Lazbuddie

Dear Santa,
I wish I could have a doll. I wish I can have a skateboard.
Love,
Deanne
Grade 2, Lazbuddie

Dear Santa,
I would like a robot and a skateboard. I want a baby for my sister.
Love,
Ronald Justin Puckett
Grade 2 Lazbuddie

I wish for a baby kitty and a big beautiful toy bear and a globe and a remote control car.
Love,
Katie
Grade 2 Lazbuddie

Dear Santa,
I want a real football jersey. I also want a puppy, and one more thing- a new 125 four-wheeler.
Love,
Don
Grade 2 Lazbuddie

Dear Santa,
I want a baby Heather. I want a ball, too.
Love,
Melissa Agiurre
Grade 2 Lazbuddie

Dear Santa,

I would like to have Teddy Rukspin for Christmas.
Love,
Lee Ann
Grade 2 Lazbuddie

Dear Santa,
I wish you would bring me a doll with batteries and two little dresses, and batteries for my radio.
Love,
Sarah Lee
Grade 2 Lazbuddie

Dear Santa,
I want a pellet gun. I want some new spurs.

Love,
Jason
Grade 2 Lazbuddie



Season's Greetings

Doing business with you has been a pleasure! From all of us to all of you: a very Merry Christmas and a Happy New Year!

**FARWELL
FEED YARDS**

Phil Treadway
Manager 481-3324

Happy Holidays



Peace to all men of good will.

MESCO **Dura Bilt** **GSI**
STEEL BUILDING SYSTEMS GRAIN SYSTEMS

(505) 762-4722
2204 MABRY DR.
CLOVIS, NEW MEXICO

JOHNNIE RUCKER Owner Res. 389-5350



Merry Christmas

To Our Loyal Friends . . .
May Peace, Good Will and
Happiness Follow You Through all the Year.

Helton Oil, Inc.
Serving the Texico-Farwell area



Our Christmas Wish For You ...

May you find among your presents on Christmas morning the priceless gift of health, happiness and prosperity. And we hope to add to your comfort by offering faithful service throughout the New Year.

Farwell Fertilizer
The Hardages

Kevin & Geneva & family Gene & Mona
Gerald & Gia & family Ed & Juanita



Texico varsity and junior varsity boys basketball team includes: front, Mark Holmes, Carl Gonzales, Kevin Spears, Byron Martin, and Urban Orozco; middle, Benjy McDaniel, Warren Martin, Hector Orozco, Jaime Estrada, Dwayne Hamilton, Pete Fuentes, Larry Powell; back, Bret Taylor, Keith Harrison, Gerald Krivanek, Juan Rojo, Darrell Krivanek, Brett Patrick, Brian Rogers, and Paul Brown.

I want Spuds Mackenzie

Dear Santa Claus,
My name is Candy, I would like a doll and some cards and a game and a computer.
Candy Davis
7 years old

Dear Santa Claus,
My name is Jeff, I am three years old. I would like a guitar, guns, and a game.
Jeff Davis
3 years old

Dear Santa,
I want a sewing machine for Christmas and a Ken doll. My brother, Daniel, wants a jumping horse. Anything you want to bring will be okay.
Thank you,
Chelsi & Daniel Kaltwasser

Dear Santa Claus,
Please bring me for Christmas a talking doll and a cheerleading suit. My brother, Jason, asks for a new train and a car. We'll leave you candy, milk and cookies when you come by.
I love you,
Megan Johnson

Dear Santa,
Please bring me Barbie's tropical pool and patio set and Baby.
Thank you,
Love,
Ashley L. Texico

Dear Santa,
I wish that Spuds Mackenzie and Alf would come true in life.

Love,
Richard
Grade 2 Lazbuddie

I would like to have an Atari, and I would like to have a computer, and I would like to have Ghost Busters.

Love,
Juan
Grade 2 Lazbuddie

Dear Santa,
I wish I could have a baby Heather and a bike.

Love,
Rhonda Toscano

Dear Santa,
I want a remote control airplane and a remote control boat and a remote control car.

Love,
Robert,
Grade 2 Lazbuddie

Dear Santa,
I want a big paint set and a remote control car. I wish we could have a happy Christmas.

Love,
Dustin
Grade 2 Lazbuddie

Dear Santa,
I wish I could have Alf and Spuds Mackenzie, too.

Love,
Chris
Grade 2 Lazbuddie



Texico Lady Wolverines Basketball team includes: (back) Krystala Cross, Josefina Martinez, Denise Gonzalez, Dena Mc Daniel, Valerie Cavallero, Leslie Steward, Ysidra Martinez, manager; (front) Leslie Cox, Robin Pierce, Twilla Longo, Tracey Askew, Geneva Garcia, Jennifer Gentry, and Jennifer Williams.

I would like a banana split

Dear Santa,
I would like a doll for Christmas. I would like a pair of skates. I would like a computer for Christmas, too. I would like a banana split, too. It doesn't matter if you do not have one. I just could have something else. I will put some cookies on a little table. I will give you a present, too.
Your friend,
Rebecca Toscano
Grade 3 Lazbuddie

Dear Santa,
Please bring me a toy truck and a bike. You may bring more presents if you like. That is if you have extra toys.
Love,
Rigo Cuervos
Grade 3 Lazbuddie

Dear Santa,
I want a new bike and a watch that has lots of buttons. I would also like two Big Foot trucks with big tires and with remote control. Also I want a toy car with small tires and a big trailer with remote control. Have a Merry Christmas.
Love,
Israel Lopez
Grade 3, Lazbuddie

Dear Santa,
Please bring me a car. I want a new bike and a pair of shoes. I also want a white pony.
Love,
Juan Reyes
Grade 3 Lazbuddie

Dear Santa,
I want a horse, saddle, and reins for Christmas. I want a cat. I want a bit map to hang in my room. I want a diamond ring for my mother. I would like a radio, batteries, cassette, and a Thesaurus for Christmas.
Your friend,
Tina Walker
Grade 3 Lazbuddie

2 to graduate

Two students from Texico were among the 256 candidates who will complete graduation requirements from Eastern New Mexico University on Dec. 18.
Official graduation ceremonies will be conducted on May 13.
Graduates from Texico include: Nita Diane Cooper, bachelor of Science in education degree in elementary education, summa cum laude; Guadalupe Olivas, master of education degree in elementary education.

WISHING YOU HAPPY TRAILS
THIS HOLIDAY SEASON



FARWELL ABSTRACT COMPANY
402 Third Street P. O. BOX 286 FARWELL, TEXAS 79325
AC 806 481-3361

We're buying and selling GENERIC CERTIFICATES

We're ready to assist
with **PIK & ROLL**



DELTON WILHITE
(806) 272-3652

1631 W. American Blvd.
Muleshoe, Texas 79347

CHRISTMAS BLESSINGS



May the feeling of peace be with you throughout this holiday season and for all of the years to come. We give you our thanks and the best wishes for a great holiday!

**Dr. Bill and Ann Green
& Staff**

Peace on Earth

Holiday greetings

Ralph & Lucille Franse

Vernon Thigpen
Jimmy Franse

John Franse
Steve Franse

Henry Garcia
Frank Landry



Farwell
Feed
Supply

Purina Horse Feeds
& Pet Food
481-3378

Farwell, Texas 79325



From Dill Dip to Potato Candy to Klochkeese

Oatmeal Bread
 6 c. flour
 2 1/2 tsp. salt
 2 Tbs. butter
 1/2 c. honey
 1 c. old fashioned rolled oats
 2 c. boiling water
 2 pkg. yeast
 1/3 c. lukewarm water
 Pour boiling water over oats. Cover and let cool to lukewarm. Dissolve yeast in 1/3 c. water. Add honey, salt and butter. Add yeast mixture to oatmeal. It will be a sticky dough. Cover and let rise till double in size. Do Not Knead. Carefully cut down with a knife. Divide into loaves. Butter tops. Placed in greased pans. Let rise for about 1 hour. Bake at 350 degrees F. for 1 hour. Crust will be brown and crisp. Butter crusts when you take it out of the oven. Let cool on a rack.

by Irene Bowery

Spice Cookies
 Sift together and set aside:
 3 c. flour
 2 tsp. ginger
 1 1/2 tsp. cinnamon
 1 tsp. ground clove

Mix:
 1 c. butter
 1/2 c. sugar

Add:
 1/2 c. dark brown Karo syrup
 Stir dry ingredients into the wet mixture. Mix well. Roll out 1/8" thick. Cut with favorite cutters. Bake at 350 degrees for 10 minutes.

by Irene Bowery

Green Chili Dip
 2 small cans chopped green chilies
 2 cans cream of mushroom soup, undiluted
 2 pkg. garlic cheese spread, tube type
 salt and pepper to taste.
 Mix in a saucepan. Stir until boiling.

by Pat Carter

Potato Candy
 1/4 c. hot mashed potatoes
 1 tsp. melted butter
 1 3/4 c. powdered sugar
 1 1/2 c. flaked coconut
 dash of salt
 1/4 tsp. grated lemon or orange peel
 1/2 tsp. vanilla
 Combine potatoes and butter in a medium bowl. Gradually add sugar, beating until well blended. Add remaining ingredients. Mix well. Drop by teaspoonfuls on waxed paper. Let stand until firm.

by Pat Carter

Eggs for Brunch
 3 c. croutons
 1 lb. ham, cubed (2 c.)
 1/2 lb. American cheese (2 c.)
 3 eggs, well beaten
 2 c. milk
 1/2 tsp. dry mustard
 1 stick melted margarine (1/2 c.)

Combine bread, ham and cheese cubes. Spread in lightly greased 9x13" pan. Combine eggs, milk, mustard and melted oleo and pour over the first mixture. Cover and refrigerate over night. Bake at 350 degrees for one hour. Makes 12-15 servings.

by Bonnie Johnson

Frozen Strawberry Dessert
 1 c. flour
 1/4 c. brown sugar
 1/2 c. melted oleo
 1/2 c. nuts
 2 egg whites
 2/3 c. sugar
 10 oz. frozen strawberries
 8 oz. Cool Whip

Mix first four ingredients. Spread on a cookie sheet. Bake at 350 degrees for 15 min. Stir often until light brown. Cool Crumble and put 2/3 oz. the crumbs in a 9x13" dish.
 Beat 2 egg whites with 10 oz. strawberries and 2/3 c. sugar for 12 min. (no less). Fold in the Cool Whip. Spread over crumb mixture. Garnish with the rest of the crumbs. Freeze until about 10-15 min. before serving.

by Bonnie Johnson

Hominy Casserole
 1 large can hominy
 1 can cream of chicken soup
 1 small can Ortega chilies



Merry Christmas

Red's Barber Shop
 Ridley Lonsdale

cheese grated to taste
 Cook hominy until done. Drain well. Add soup, chilies, and cheese. Put in baking dish and sprinkle top with cheese. Bake at 300 degrees for just a few minutes until the cheese is melted.

by Bonnie Johnson

Red Devils Food Cake
 6 Tbs. cocoa
 1 c. boiling water
 1/2 c. butter
 2 c. sugar
 1 c. milk
 2 1/2 c. flour
 2 tsp. soda
 1/2 tsp. salt
 2 egg yolks
 2 egg whites, stiffly beaten
 1 tsp. vanilla
 Mix soda into the flour. Pour water over cocoa and cook until thick. Cream butter and sugar together. Beat flour, milk, soda, salt, egg yolks and vanilla into the butter mixture. Add the cocoa mixture. Beat together and fold into the egg whites. Bake at 350 degrees. Makes 3-9 inch layers.

by Bonnie Johnson

Pineapple Filling
 large size crushed pineapple
 1 c. sugar
 2 T. flour
 2 T. butter
 Strain juice from pineapple. Add it to the flour, sugar and butter. Cook until thick. Add pineapple pulp. Spread between layers and on top of cake.

Klochkeese
 1 lb. butter or margarine



Glad Christmas Tidings

Otis McMillan Renee Bartlett Gary White
 Weldon Embrey Priscilla Herington Lynne Mahaney

1 lb. cream cheese
 1 lb. flour (4 cups)
 2 cans pie fruit filling
 Cream butter and cheese. Add flour. Refrigerate. Roll out dough 1/4" thick. Cut into 2" squares. Put 1 spoonful of pie filling in the center of each square. Bring two corners of the square together. Press lightly to hold the two corners together. Bake at 425 degrees until lightly brown. Sprinkle with confectioner's sugar.

French Silk Pie

2/3 c. sugar
 1 stick margarine
 1 1/2 squares unsweetened chocolate
 1 tsp. vanilla
 2 eggs
 chopped pecans (optional - may be added if desired)
 Cream sugar and margarine. Add melted chocolate and vanilla. Add 1 egg and beat 5 minutes. Add a second egg and beat 5 minutes more. Pour into baked pie shell. Top with shredded chocolate and chill.

Coconut Butter Balls
 1/2 c. butter
 2 Tbs. powdered sugar
 1/2 tsp. vanilla
 1 c. flour
 3/4 c. fine grated coconut
 Cream butter; add sugar and vanilla. Beat until light and fluffy. Add flour all at once and blend well. Add coconut, mixing well. Shape into small balls and place on ungreased baking sheet. Chill 15 min. Bake in a moderate oven (350 degrees) for 15

min. until delicately browned. Roll in powdered sugar while warm.

Chocolate Meringues

1/8 tsp. salt
 2 egg whites
 1/2 c. sugar
 1/2 tsp. vanilla
 1/2 c. coconut
 1/4 c. chopped walnuts
 1 pkg. (6 oz.) semi sweet chocolate chips, melted
 Add salt to egg whites and beat until foamy throughout. Add sugar very gradually, beating well after addition. Continue beating until stiff peaks will form. Add vinegar and vanilla and beat well. Fold in coconut, nuts and melted chocolate.

Drop by teaspoonfuls onto greased baking sheet. Bake in moderate oven (350 degrees) for 10 min. Makes 2 1/2-3 doz. cookies.

Dill Dip

1 c. sour cream
 1 c. Hellman's mayonnaise
 2 Tbs. Dill weed
 2 Tbs. diced onion
 2 Tbs. parsley flakes
 2 tsp. Lowrey seasoned salt
 Combine ingredients. Chill until serving time.

by Robyn Palady

To Subscribe
 Phone 481-3681

Meet Texico's Class of 2000
 Keegan Chandler-Autrey's birthday is March 13. He is in Mrs. Jenkins' class.
 He is the son of Allen (Sarge) Autrey and Elaina S. Chandler-Autrey. He has a brother, Keaton.
 His grandparents are Lucie and Lance Somers and Pat R. Chandler and Shorty and Don Gillis and the late T.A. Autrey, Jr.
 Keegan likes to color, play on the playground equipment with kids, play with his toys, and work in the truck with his dad.



Sponsored by ENMR Telephone Cooperative
 "Owned by those we serve"



Christmas Joy
 From Your
Courthouse Officials

Porter Roberts
 County Judge

W.C. "Bill" Morgan
 County Sheriff

Bonnie Warren
 County Clerk

Hugh Moseley
 County Assessor-Collector

Benna Felts
 County Treasurer

Charles Aycock
 County Attorney

Marjorie Watkins
 District Clerk

Robert White
 Commissioner Prct. 3

Albert Smith
 Justice of the Peace Prct. 1

Jack Young
 District Court Judge

Raymond McGehee
 Commissioner Prct. 4



Holy Night

On a starry night almost two thousand years ago, the first Christmas started with a child. Since that time, Christmas has had a special meaning for young and old alike, all over the world. For Christmas is a time of great love, great happiness and great hope.

As we celebrate again that magical moment, let us pray that the true spirit of Christmas be reflected in the hearts of all men. And may the special promise of the first Christmas child bring us all to a new and glorious morn.

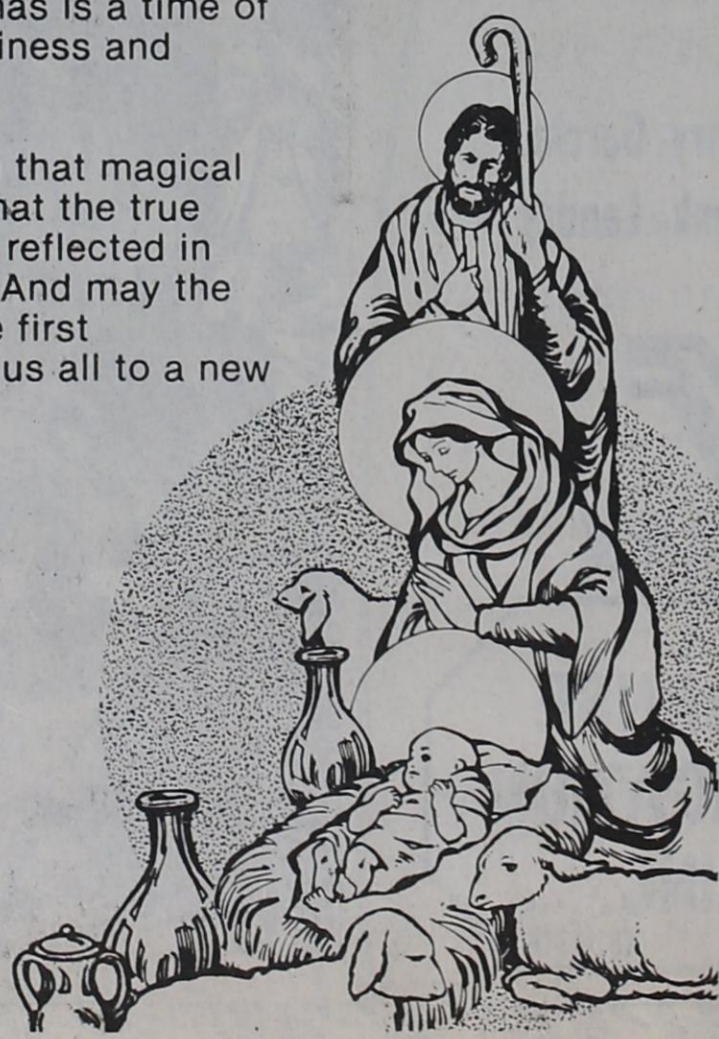

Avis Haile	Anna McDonald	Benny Rivera
Billy Askew	Ismael Rodriguez	Jimmy King
June Ortiz	Bernadette Flores	Pam Edwards
Shamra Lovelady	Ramon Sanchez	Jesse Mancayo
Michael Russell	Lynn Tubbs	Roger Martinez
Ysidro Ortego	Phillip Moore	Linda Myers
Mr. and Mrs. Charles Bell	Mr. and Mrs. Benny Haney	

CAPITOL FOODS
 9th & Ave. A Farwell 481-3432



Donations

Above, Gladys Hardage of the Farwell Study Club gives Carla Kaltwasser, a member of the Parmer County Welfare Board, a check for \$100 on behalf of the club to buy Christmas presents for foster children in Parmer County. Below, Mrs. Hardage and Bill Pennington view the coat rack and hat rack donated by the club to the Farwell Community Center.

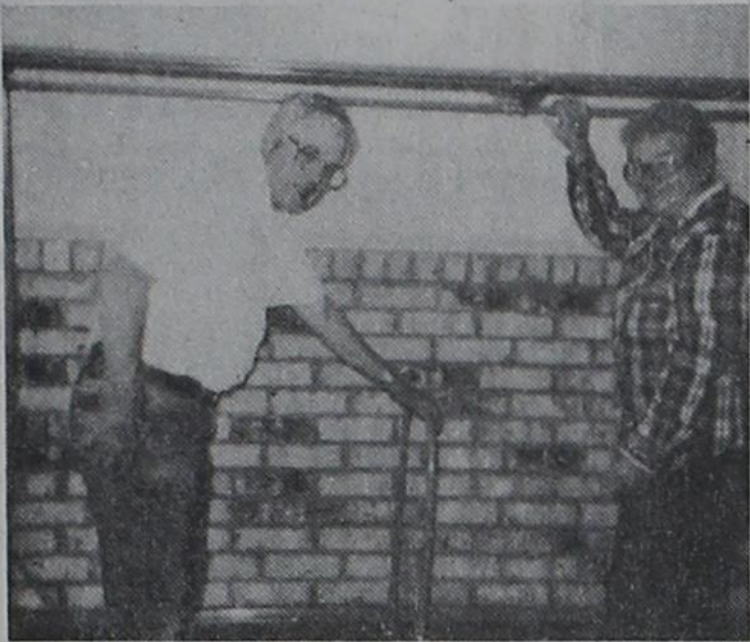

Something to celebrate

(Editor's note: Lucille Franse saved an essay that was written by a student she taught several years ago. It was written at the start of the bicentennial celebration. Mrs. Franse asked that we print this in honor on the bicentennial of the U. S. Constitution. The person who wrote this lives in our community today.)

As we celebrate the year of bicentennial we are reminded that some have more to celebrate than others. The following account is a true story.

My story is about my mother and how she arrived in the United States. She came over with my grandparents and her sisters.

The year was 1953, and the place was Nuevo Laredo, Mexico.

My father decided to come to the United States because food was very scarce for my family at the time and he didn't want us to suffer from hunger anymore.

We were four small girls. I was the second from the oldest, being only nine years old.

The night that we left, we were helped by some

friends of the family who took us to the river to help us cross. They helped us get on a wooden raft to be taken across. I guess I will never forget the water and how cold it felt under the raft.

My whole family was very scared because we were afraid of maybe getting spotted. I felt very alone at the time, even though my family was with me. I was also very sad at having to leave my native country, but I knew that if we stayed, it would be bad for all of us.

When we reached the dry land again, we had to be very careful and not get caught by the border patrol. We hid in the woods for four days and nights and met other families traveling for the same reason and other families going back because they couldn't "make

it" in the United States. We were cold and very hungry and always praying to God that we would reach our destination safely.

The day came when we did reach the place we were coming to - a ranch in Mission, Texas, where my father was going to work. When we arrived, we didn't go to school. We had to help our father work, hoeing cotton or doing any kind of labor. As time passed, we were better off and my father sent us to school.

My father helped all of us get passports. Later, another brother and sister were added to the family as American citizens.

I owe my life to my father, who with his pride and courage brought us here to the United States of America.

'I want a fur coat'

Dear Santa

I want a vcr along with a tv. I also want a Rocker Barbie, along with Ken and the group. Most of all I want a globe, a spiral, a little desk, and a map of the United States of America. I also want a fur coat. I want a chalkboard.

Love,
Angela Willingham
Grade 3 Lazbuddie

Dear Santa,
It is nearly Christmas. I might put some cookies on the kitchen table for you to eat. I hope I will get an Amazing Baby Heather. I also want a Jewel Secret.

Love,
Janis Hernandez
Grade 3 Lazbuddie

Dear Santa,
I want a ring and a washable fur coat. I also want a stocking full of goodies.

Love,
Mandy Magby
Grade 3 Lazbuddie
P.S. I will leave some milk and cookies.

Dear Santa,
This year I want a two deck radio because my sister, Staci dropped mine and broke it. I also want a telescope and I want everybody to have a Merry Christmas.

Love,
Shana Foster
Grade 3 Lazbuddie

Peace on Earth

Christmas began in the heart of God. It is complete only when it reaches the heart of man.

- Author Unknown



Interested in joining the Lions Club? We meet the second and fourth Mondays of every month at 7 p.m. CDT at Luce's Spur Restaurant. Visitors are welcome. Please come and see what we're involved with.

Fruit Cake

No Bake Fruit Cake

- 1/2 c. evaporated milk
- 2 c. miniature marshmallows
- 3 Tbs. orange juice
- 3 1/2 c. graham cracker crumbs
- 1/4 tsp. each: cinnamon, nutmeg, cloves
- 1/2 c. raisins
- 1/4 c. finely chopped dates
- 1/2 c. chopped candied fruits
- 1/2 c. chopped walnuts
- 1 1/3 c. coconut

Line bottom and sides of 8x 4x 3" loaf pan with waxed paper and set aside.

Combine milk, marshmallows, and orange juice in a small bowl; set aside.

In a large bowl, mix graham cracker crumbs and spices. Add fruit, nuts, and coconut; mix well. Then add milk mixture. Mix until moist and sticky. Press firmly into lined pan.

Wrap in waxed paper or aluminum foil. Chill two days before slicing. Store in cool place.

BLESSINGS TO ALL



... the Spirit of Christmas is the spirit of love ...

Wishing you
Santa's Best

Farwell Hardware

The Neil Stewart Family

The Ricky Stewart Family

Christmas Cheer



May the sights and sounds and smells of Christmas bring joy to your heart and peace to your being.

BEST WISHES

Farwell Insurance Agency

Connie Hammit

481-9372

Patricia Landrum

4-H'ers test food, nutrition expertise

Four-H'ers tested their foods and nutrition expertise in the Farmer County 4-H Food Show held Dec. 5 in Bovina.

Fifty youths competed in Pee Wee (younger than 3rd grade), Junior 1 (3rd-10th grade), Junior 2 (11-13 years) and Senior (14-19 years) age groups. According to Janette Pierce, county Extension Home Economist, 4-H members competed in one of four classes including main dish, fruits and vegetables, breads and cereals or nutritious snacks and desserts.

"The food show was not just a cooking contest," said Pierce. As a result of club project series in each community, youth demonstrated what they had learned about nutrition, meal planning, food buying, and meal service, as well as food preparation at the food show.

After judging and a tasting fair the fair, the following honors were recognized:

Pee Wee participation ribbons went to Deanne Clark, Dene Clark, Holly Engelking, Dustin Weir, Amber Richardson, Scottie Brown, and Kia Morris of Lazbuddie; Jamie Slagle, Jason Slagle, Alicia Smith, Jacy DeLeon, Jeff Hamilton, Amanda Hicks, and Kevin Schueler of Friona; and Ramsey Bennett and Ginger Sides of Farwell.

Junior 1 awards were given for Main Dish: 1st place, Jenny Hamilton, Friona; 2nd place-Davy Hamilton, Friona; and 3rd place-Heath Brown, Lazbuddie. Participation awards went to Kayla Clark and Edward Terry of Lazbuddie and Amy Hartzog of Farwell.

Fruits and vegetables awards were given for: 1st place-Julie McDonald, Lazbuddie; 2nd place, Canna Ray, Friona; and 3rd place, Dawn Weir, Lazbuddie. Participation awards were presented to Rachelle Rice of Lazbuddie and Jim Bob Sides of Farwell.

Breads and Cereal awards went to: 1st place- Krista Smith, Lazbuddie, 2nd place, Jacque Sides, Farwell; and 3rd place, Wade Schueler of Friona. Participation awards were presented to Heather Engelking and Noah Williams of Lazbuddie.

Nutritious Snacks and Desserts awards were given to: 1st place, Mandy Magby, Lazbuddie; 2nd place, Roslyn Bennett, Farwell; and 3rd place, Julie Mitzelfelt, Farwell. Participation awards were presented to Becca Beard, Jennifer Hamil and Lindsey Johnson of Friona and Michelle Dorcas of Farwell.

Junior 2 Main Dish awards went to: Ginny Mitzelfelt, Farwell; 2nd place, Jarah Redwine, Lazbuddie, and 3rd place, Laura Goen, Friona. Participation recognition was awarded to Eric Williams of Lazbuddie.

Fruits and Vegetables awards went to: 1st place Melinda Landrum, Farwell, and 2nd place, Lance Goen, Friona. Bread and Cereal award went to Marsha Autry of Lazbuddie.

Nutritious Snacks and Desserts awards were earned by: 1st place went to Jody Copp, Lazbuddie; 2nd place, Monty Schueler, Friona; and 3rd place, Heather Smith of Friona.

Senior Main Dish: 1st place Morris of Lazbuddie first place.

Nine Farmer county junior and senior first place winners will compete with youth from 20 South Plains Counties Dec. 12 at Texas Tech in Lubbock.



Junior Winners Julie McDonald, Mandy Magby, Krista Smith, and Jenny Hamilton



Junior 2 Winners Jody Copp, Marsha Autry, Melinda Landrum, Ginny Mitzelfelt.

Christmas cookies

Christmas Crescent Cookies

- 1/2 lb. butter
- 2 c. flour
- 2 c. chopped pecans
- 5 Tbs. sugar
- 2 tsp. vanilla
- 1 Tbs. water
- 1/2 tsp. salt
- powdered sugar

Cream butter and add sugar, vanilla and water. Stir flour and salt together and stir into creamed butter mixture. Add pecans and mix thoroughly. Using portions about the size of a walnut, roll into crescent shaped cookies. Bake in a slow oven (325 degrees) about 20 min. While warm, roll in confectioner's sugar.

Double good pumpkin pie

- 2 eggs, slightly beaten
- 1 can of pumpkin (16 oz.)
- 2/3 c. sugar
- 1 tsp. cinnamon
- 1/2 tsp. salt
- 1/2 tsp. ginger
- 1 1/3 c. half and half (or use evaporated milk)

- 2 unbaked pie shells
- 2 c. sour cream
- 4 Tbs. brown sugar
- 2 Tbs. lemon juice
- grated peel of 1 lemon
- Mix eggs, pumpkin, white sugar, cinnamon, salt, ginger,

and half and half together. Pour into pie shells. Bake at 425 degrees for 15 min. Reduce heat to 350 degrees and bake for 45 min or until knife inserted into pie comes out clean. Cool for 20 minutes.

Blend sour cream, brown sugar, lemon juice and lemon peel together. Pour over the pumpkin layer.

NOEL



Rejoice and be glad!
The Savior has come! Let us proclaim His glory!

CECIL'S
TEXACO
Cecil Rundell, Prop.

PARTS VALUE OF THE MOUTH.

Pre-Season Service Savings

YOU

CAN HAVE AN ON-FARM INSPECTION OF YOUR EQUIPMENT AND SAVE ON SERVICE WORK, TOO



SAVE 10% on parts when service is done in our Service Center

plus SAVE 10% on labor

That's right! We'll send a service technician to your farm to inspect your tractor, combine, or planter. It's called the Performance Plus Checkup, and it's designed to cover every detail of your Case, IH, or Case International equipment. When our man is through, you'll know exactly the operating status of your equipment. If work is needed, we'll do it then at our special Pre-Season discount and you'll be ready for your busy season now. Get an on-farm inspection and Pre-Season Service Savings!

case ih

Offer expires Jan. 30, 1988

C&H Equipment

W. Highway 84, Muleshoe
272-5514



Senior Winner Holly Morris

A Joyous Christmas

May all the blessings and happiness of this holy season be bestowed on you and your family. Have a Joyous Holiday.

We wish all the residents of Texico

Warm Christmas Wishes

Mr. & Mrs. John R. Hadley

Holiday Brightners

May your Holidays be filled with
The warmth of friendly faces
The mending of differences
The joy of sharing and
The peace of understanding.

Wishing holiday happiness to our community's citizens and their families



Lovelace Oil Company

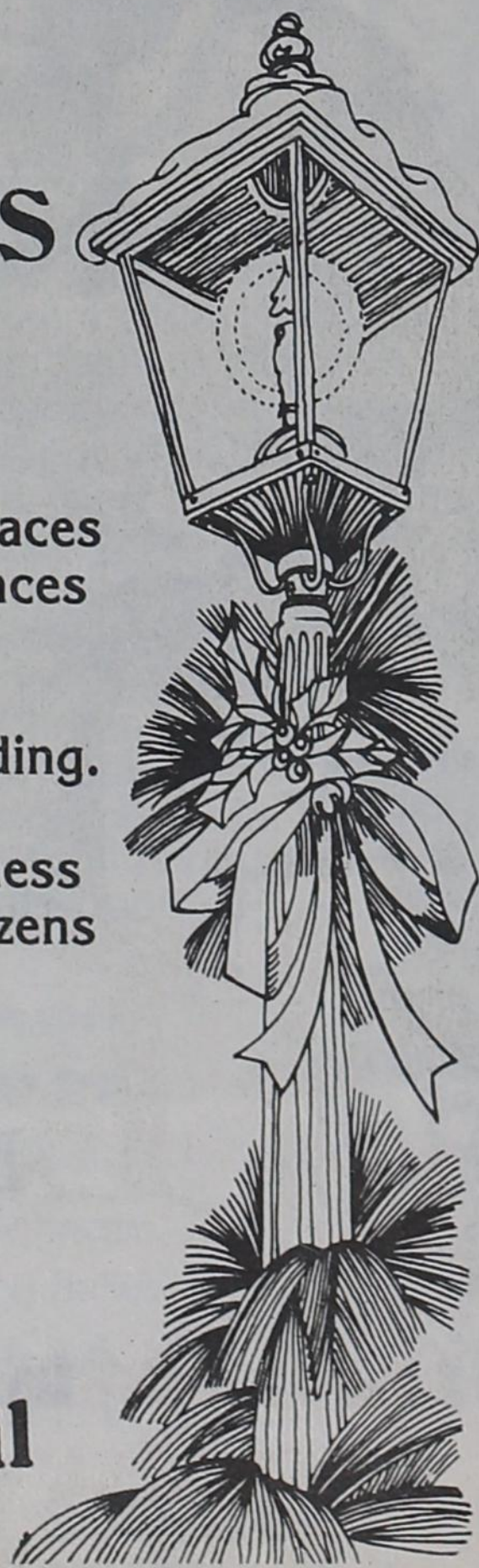



Joy to the WORLD

At this season of the year it is our sincere hope that happiness and prosperity find their way into the homes of all our friends, and remain with them throughout the year.

109 5th St.



Sudderth Realty, Inc.

806/481-3288

Explosives topple platform

By WILL ANDERSON

I had the watch in flag plot on Oct. 16 when the initial reports began to come in that the tanker "Sea Isle City" had been hit by a missile in the port of Kuwait. ("Flag plot" is the space onboard the USS LaSalle used by the Commander Middle East Force as a communications and control center for operations in the Persian Gulf)

Damage was extensive, a number of the crew were injured and the ship's master was blinded in the attack. The attack was launched by Iran the missile they fired (a Chinese built Silkworm) locked onto the "Sea Isle City" as she proceeded to a pier-side berth in Kuwaiti waters following her escort through the Persian Gulf by U.S. warships.

The U.S. response came three days later, on Oct. 19, with the destruction of the oil platforms at Rostam. The platforms had been attacked earlier in the Iran-Iraq War by Iraqi forces and were not presently producing oil. They were used by Iran, however, as a base for surveillance and coordination for their forces in that part of the gulf.

The attack on the platforms was to be accomplished by four destroyers. USS Leftwich had Commander Destroyer Squadron 35 embarked as the officer in overall command

of the attacking ships. Desron 35 was my sister squadron in Pearl Harbor, where I was stationed for two years, and the USS Leftwich was our flagship.

The USS Leftwich came through the Straits of Hormuz with destroyer USS John Young and Guided Missile Destroyer USS Hoel. They were joined in the gulf by Guided Missile Destroyer USS Kidd, who was already on station.

It seemed appropriate that the USS Kidd should be involved in the attack because she and three of her sisters were built originally for the Shah of Iran, but never delivered after the taking of the U.S. Embassy in Teheran in 1979. The four ships are officially 'Kidd Class DDG's' but are commonly referred to as "Ayatollah Class DDG's" for that reason.

USS Thach, a guided missile frigate, embarked a detachment of explosive ordnance disposal (EOD) personnel and closed the area of the platforms from the north as the destroyer force closed from the south.

At 20 minutes prior to H-Hour, she began broadcasting a warning to the Iranian personnel on the platforms to escape immediately to avoid the imminent destruction that was to follow. These broadcasts continued until the moment the guns opened up. Iranian personnel were observed departing in boats.

All four destroyers have 2 five-inch gun mounts, capable of firing a round every few seconds continuously. Each projectile weighs more than 60 pounds, largely high explosives and have a range in excess of 10 miles. The bombardments commenced from a range of less than four miles, and continued until over 1,000 rounds of ammunition had been expended and one platform was completely engulfed in flames.

When the firing completed, the EOD teams approached the other platform in their Zodiac rafts and rapidly climbed onboard. Explosive charges were set on the legs supporting the platform, timers set and the teams hurried back to USS Thach standing by. The explosions they set completely toppled the platform into the sea.

The attack degrades Iranian surveillance and coordination in that area of the gulf. It also demonstrates the capabilities of the U.S. forces there. And Iran must consider the consequences of her hostile acts before she executes them. The attack was completed without damage to U.S. warships, and without known injury to Iranian or U.S. personnel.

The USS Leftwich, USS John Young and USS Hoel returned to their duties in the Gulf of Oman and North Arabian Sea after the attack. The USS Thach and USS Kidd remain in the Persian Gulf, and the USS LaSalle continues her patrols.

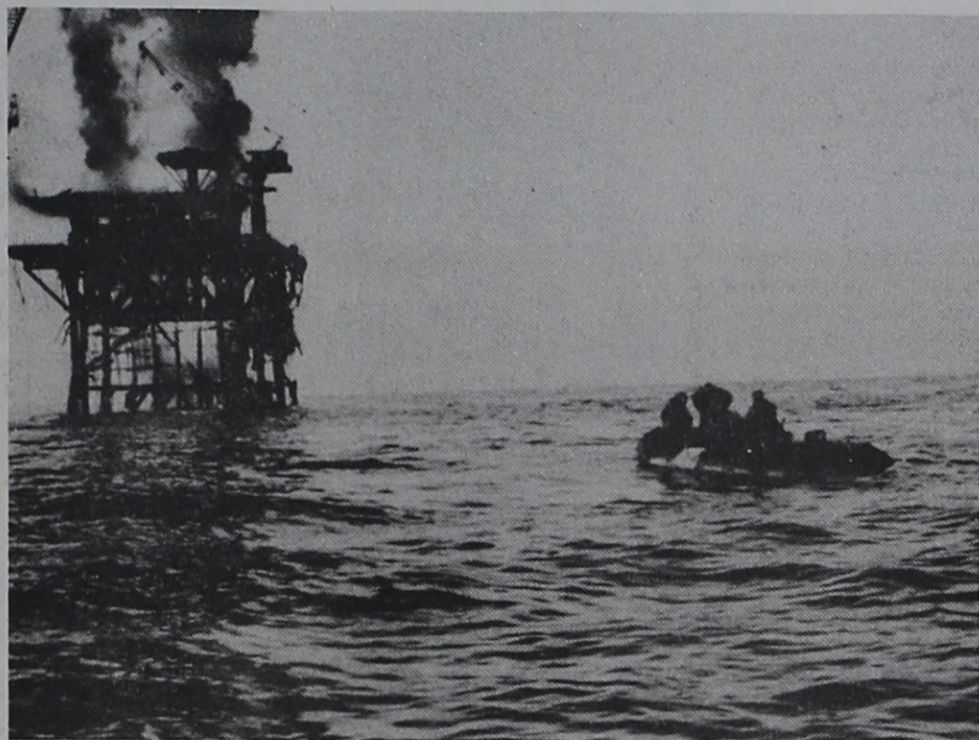

The Explosive Ordnance Disposal team sets explosive charges on the Rostam oil platform.

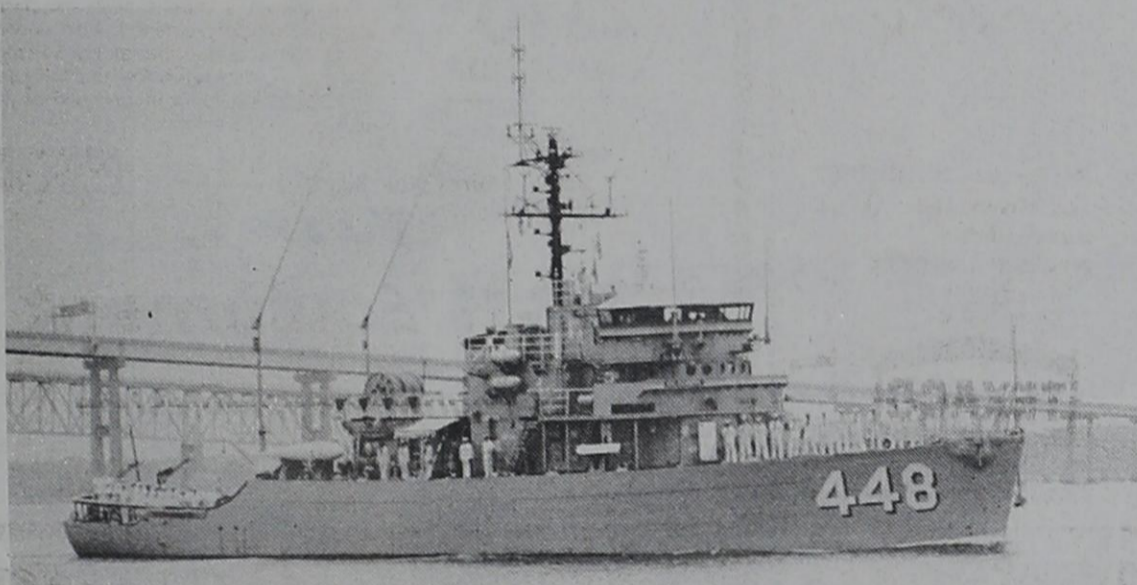

The USS ILLUSIVE is one of the minesweepers on duty in the Persian Gulf.

'I want some horse teeth'

Dear Santa,
I want some horse teeth and a turbo hopper car.
Love,
Brice R.
Grade 2, Lazbuddie

Dear Santa,
I wish to get a pair of boots and a bike for Christmas. I want a necklace that has an "S" on it. I want a set of pencils and pens.
Good bye.
Your friend,
Sulema Moran
Grade 3 Lazbuddie

Dear Santa Claus,
This year I want to tell you what I want for Christmas. I want a jewelry box and a doll house. I want a new bike. I want a Madonna tape and a Chipmunks tape, too. I also want a radio.
Love,
Amy Autry
Lazbuddie Grade 3

Dear Santa,
I want a game called Wheel of Fortune. I have wanted it for a long time. I used to watch it on tv. I want a toy computer for my sister so that she could use the cards and the square thing. I might not be in my house by Dec. 19th.
Your friend,
Rebecca Mata
Grade 3 Lazbuddie



:May
the Joy
and Peace
of
Christmas
always
be
with You

Merry Christmas

Berry & Kirkland, CPA
And All The Staff
Farwell, Texas

Serna to receive degree

Anita Firms Serna from Texico is among 256 candidates who will complete graduation requirements from Eastern New Mexico University on Dec. 18.

Official graduation ceremonies will be conducted on May 13, 1987.

Serna will receive a bachelor of science degree in sociology.

Joyeux Noel



Hope your Christmas is absolutely heavenly!

James Chadwick
Texas Farm Bureau Insurance
481-9014 247-3963

Work done in our Service Center saves

10% ON PARTS PLUS
SAVE 10% ON LABOR



40 H.P. & UNDER TRACTORS
250⁰⁰ MIN.*

40 H.P. & OVER TRACTORS
500⁰⁰ MIN.*

CASE POWER AND EQUIPMENT

4100 MABRY DR. CLOVIS, N.M.



762-4453



"... Christ,
our Savior, was
born on Christmas
Day..." They came from
near and far to bestow their
gifts upon Him. May the holy
spirit of the season abide with
you during this wondrous time!



LUNSFORD AUTO PARTS
FARWELL PIPE & IRON
The Lunsford Family

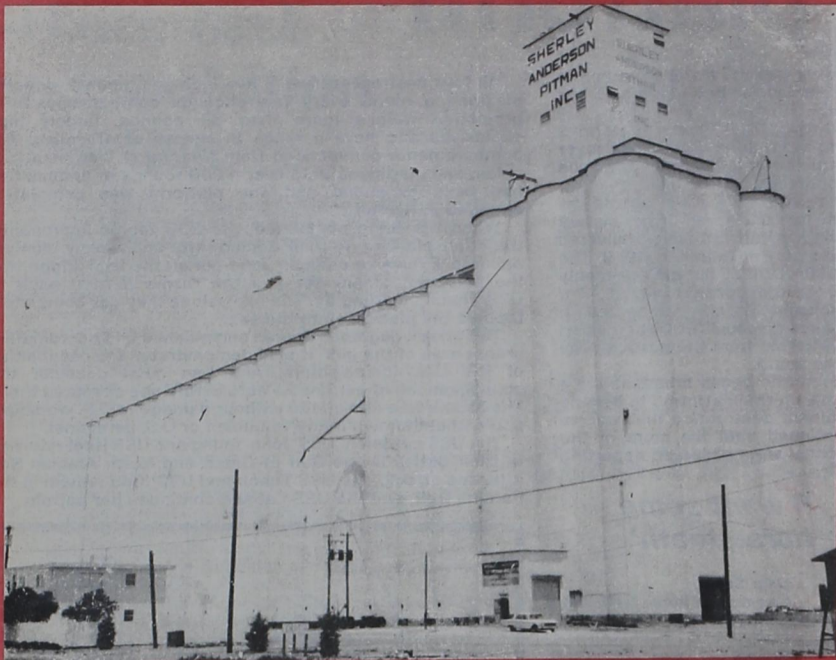

A MERRY CHRISTMAS

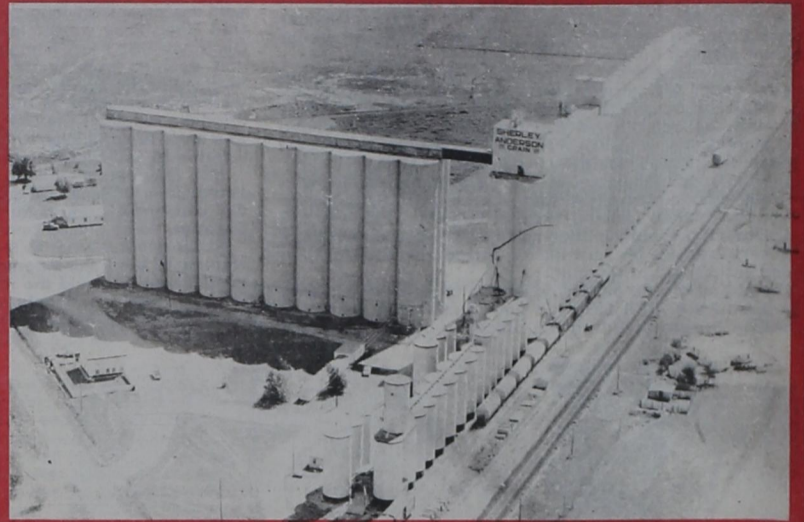

Sherley-Anderson-Pitman, Inc.-Farwell
JOHNNIE WILLIAMS-FRED CHANDLER-BOBBIE MCFARLAND

Sherley-Anderson Grain Co.-Lariat
LONNIE MCFARLAND-DON GARTIN-JOHN MCFARLAND

SERVING PARMER COUNTY FARMERS THE YEAR 'ROUND

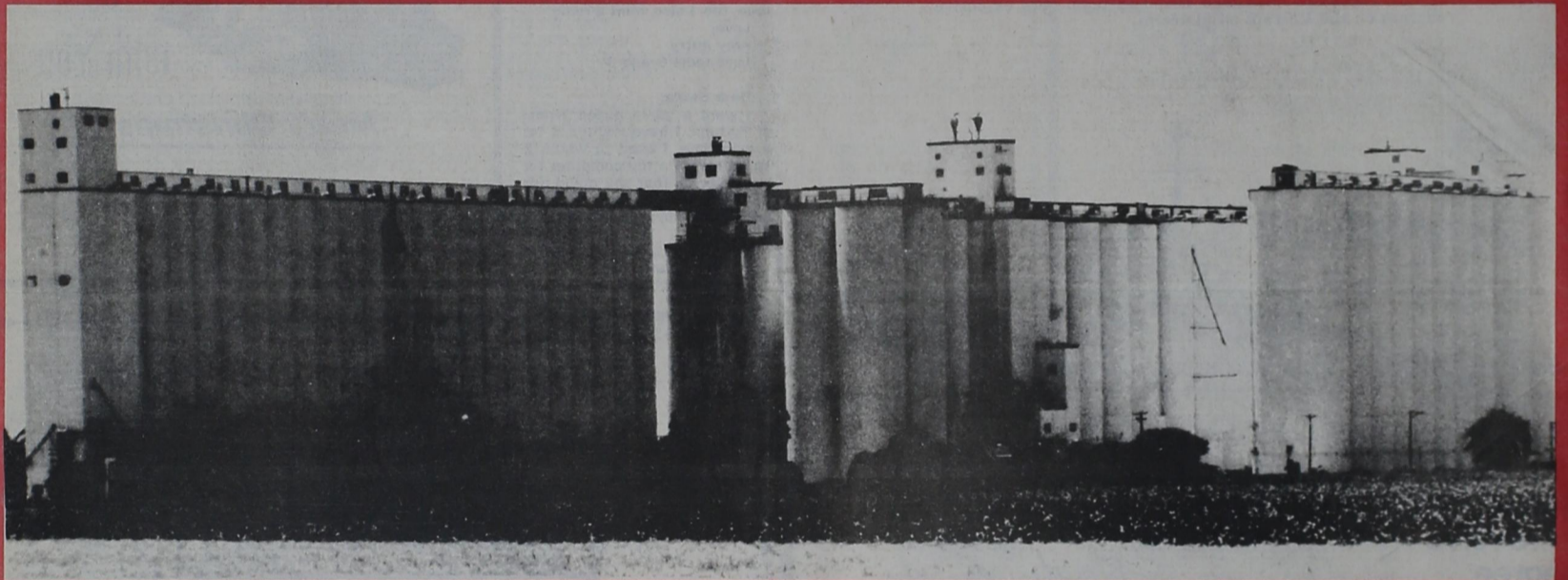

Sherley Grain Co. - Bovina



Sherley-Anderson Rhea Elevator
JOE & MARTHA ALLEN

Sherley - Anderson
Lazbuddie Elevator

DAVID ANDERSON-SCOTT BROWN-RAY STANLEY

Christmas in Spain

by Juanita Hadley

Texico, New Mexico, is a long way from Oviedo, Spain. This year Juan Rojo of Oviedo is attending Texico High School as an exchange student; he is sharing the home of Mr. and Mrs. Kenneth Shaw, Kenny Michael, Natasha, and Amber. Mr. Shaw is principal of Texico High School.

Although Juan has returned to Oviedo for a reunion with his family during the Christmas holidays, earlier he spoke at length of the celebration of Christmas - Spanish style.

On the subject of Christmas, Juan's first reaction was that Christmas is about the same in both his country and in his adopted country. He pointed out first one tradition and then another that are alike in both places, but to his surprise he soon also mentioned one tradition after another that are not alike.

As we take a look at Christmas in Spain, we shall attempt to discover both the similarities and the dissimilarities.

Since Spain is an almost totally Catholic nation, the religious aspects of the holiday are uppermost; however, there are also numerous other traditions and customs.

Early in December, shopping areas begin to reflect the coming holidays with multicolored lights, often arranged in the shapes of stars or bells. Oviedo's city park especially sparkles with the lights. But, as Juan explains, private homes do not usually display lights.

Also present are Christmas carols. Stores and radio stations surround shoppers with melodies known almost universally, and just last year the city of Oviedo installed a sound system downtown for the Christmas songs. Strains of "Noche de Paz" ("Silent Night") and "Adestes Fidelis" ("Oh, Come All Ye Faithful") are interspersed with such well known tunes as "We Wish You a Merry Christmas" and "Jingle Bells." According to Juan, just about everyone knows the last two in English.

Carolers are also common during the holiday season with small, neighborhood or family groups traveling about. On occasion, churches or organizations such as the Boy Scouts, may use carolers to raise money for special projects. However, Juan stresses, most of the singing is strictly for fun.

On very special aspect of Christmas decoration in both homes and public places, is the nativity scene. Stores and other businesses utilize the scenes as drawing cards for customers. Some such establishments go all out, and there is brisk competition to see which places can exhibit the most elaborate arrangements. In the larger, more expensive displays, there may be human-size, electrically animated characters, running waster, bridges, trees, and the like. Juan notes that banks usually offer the grandest, most elaborate nativity scenes.

Catholic churches often sponsor live indoor nativity plays (which normally last about half an hour), as do many local theaters, where the activities frequently feature not only real people, but also real animals.

The nativity scene is also very much a part of private holiday tradition. Big or small, every home has one. Children, in particular, enjoy making their family scene special. Juan remembers adding such items as fake grass, a mirror representing water, a small bridge, and "flour" snow.

The tree, also a vital part of Christmas custom, is not usually put up until after area schools have dismissed for the holiday break. While some families still prefer real trees, the Rojos have opted for the artificial type. Decorations normally include lights, shiny balls, and a topper of some sort. Juan's family chooses to display a star at the top, but others may have an angel or perhaps a gold ball instead.

Although Spanish residents do not decorate for Christmas as much as most Americans do, the houses "look different" with the tree, nativity scene, some candles, and especially just more color.

Along with Christmas carols, lights, and trees is another Christmas tradition, a very rich candy called turrón, which comes in a variety of flavors, such as almond, hazelnut, caramel, white, and chocolate. Most varieties are tough, rather like taffy, with white turrón being the exception. Juan adds that the chocolate flavor has been marketed for only the past ten years or so. The sweet, which originated in the southeastern region of Spain is produced by only a few family-owned factories, some having been in the business for over two hundred years, and Juan explains, those who make the candy are considered to be artists in their field.

Consumers purchase several different varieties of the confection, each package a long, flat parcel and sold by the pound. For serving, the turrón is cut into squares, and the different types are placed on a flat dish. According to Juan, the treat is so rich that only a small amount can be eaten at a time.

In recent years Santa Claus, also known as "Papa Noel," has entered into Spanish tradition. He is the same bearded "fat man," dressed in red who resides at the North Pole. Although he travels by sleigh, he is pulled by only eight reindeer, since Rudolph is not yet part of the Spanish picture. In the weeks preceding Christmas, Santa is frequently featured in television commercials and may be found in larger department stores, listening to children's wish lists. There are no letters sent to Santa, though.

There is some ambiguity concerning Santa's role since he is a newcomer. Although commercials depict the jolly old fellow laying out gifts on Christmas Eve, every Spanish boy and girl knows that those presents are brought, not by Santa, but by "Little Jesus." The Child is not promoted by newspaper, radio or television; nonetheless, He is a very definite part of oral tradition.

Christmas Eve, which Juan refers to as "the night of twenty-four," is not the major gift-giving time in Spain. On that night, only small, usually inexpensive presents are exchanged by family members or left by Little Jesus. Stockings are not hung, but may be laid out on the floor around the tree.

The Rojo family almost always follows a set routine on Christmas Eve and Christmas Day. They start out with a visit to the home of the paternal grandparents in the early evening, around eight o'clock, followed by dinner with the maternal grandparents around ten or ten-thirty. Juan reports that Christmas Eve dinner is truly nice, and that most families "spend lots for this meal."

One of Juan's very pleasant childhood memories of Christmas Eve with his mother's parents involves their unique way of presenting the small gifts to the grandchildren. Usually the gifts were hidden, perhaps under the table, with the excitement mounting as Juan, his brothers and sister, and cousins sought and finally found the boxes.

Other childhood memories include little plays, prepared ahead of time, that were presented for the enjoyment of parents, grandparents, aunts and uncles, and other family members. Although such entertainment was not an annual event, Juan remembers taking part in several through



A Visit with one of the Reyes Magos

Pictured are Juan Rojo and his younger brother, Rafael, who have just completed expressing their "want list" to Baltasar, one of the three kings who bring gifts to Spanish boys and girls on the night of January 5. Baltasar is assisted by a small servant in the tradition of the kings who came from the East, bearing presents for the Christ Child. The rolled paper in Rafael's hand may well be the letter brought by the boys, which also details their most wanted items. Such letters are deposited in the trunk on which Juan is seated. In many instances, both the kings and Santa are present in the same department store. However, Santa is of much less importance than the Magic Kings.

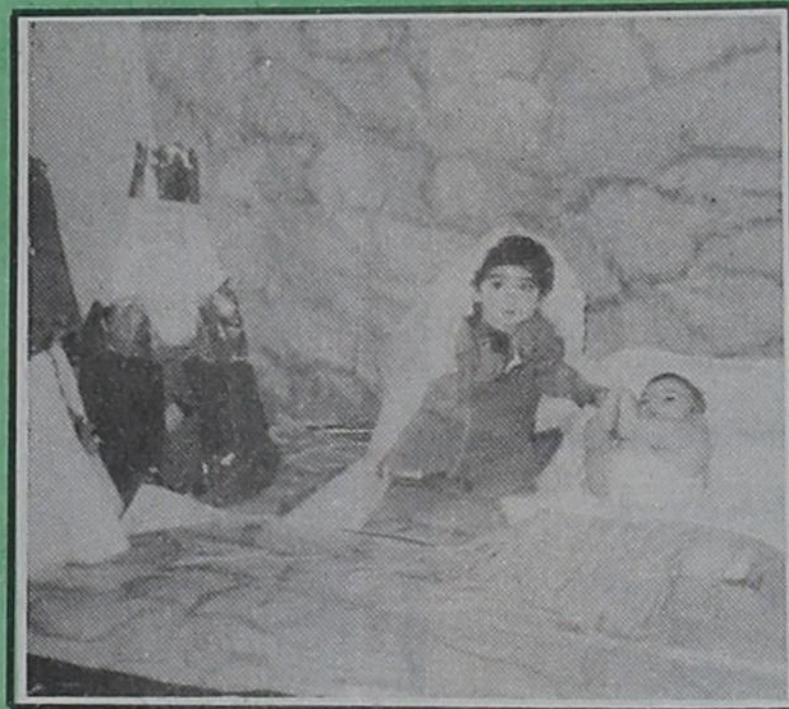

Christmas Eve Entertainment

Nativity re-enactments play a large role in Christmas celebrations in Spain. Catholic churches, theaters, and in this instance, family members present the Biblical story. Juan Rojo explains that some of his fondest memories of Christmas Eve at his mother's parents' home are the "little plays" performed by his brothers, sister, cousins, and himself. However, Juan does not remember participating in the play pictured above, for he is portraying the Baby Jesus. Older sister Marta is the proud and watchful Mary. Juan, now 19, has completed high school in his native Spain and is spending the current year as a student at Texico High School, living with the Kenneth Shaw family. Marta, now age 21, is studying pharmacy in Madrid.

the years. He comments that his young cousins do not participate in the plays.

Though the family productions are no longer presented, there is still plenty to do after dinner. Usually everyone sits down to some type game, the most common being cards or Trivial Pursuit.

On Christmas Day, both sets of grandparents, who happen to live within a block of Juan's family, arrive for lunch, which is normally served about two-thirty in the afternoon. As a child, Juan remembers having turkey on Christmas Day, but more recently, the family leans toward roast beef and especially seafoods. In addition there are wines, vegetables and desserts.

Also, at some time during Christmas Day, the Rojos, as do other Catholics, attend mass.

Christmas cards are not a part of the holiday celebration; however, many Spaniards write letters or send telegrams to distant friends or family members. Also, many choose to telephone loved ones on Christmas Eve.

The next major event is New Year's Eve, which is celebrated quite similarly to its American counterpart. In one way, though, there is an obvious difference. Most parties do not begin until after midnight, with families usually choosing to remain together until that time. During Juan's younger



Typical Christmas Eve

A younger Juan Rojo, exchange student from Oviedo, Spain is shown second from left with his mother, sister, and brother. Gifts exchanged on Christmas Eve are small and inexpensive, with larger items reserved for January sixth. Family trees are not elaborately decorated. Small children receive presents, also small, from Little Jesus rather than from Santa Claus.

years, New Year's Eve was normally spent with his father's entire family at the grandparents' home.

Spanish television provides entertainment through the entire night, featuring different movies, singers, and especially, comedians of the Johnny Carson type. Standard topics include jokes about the new year. And there are always the commentaries reviewing the old year.

Often families view televised festivities in Madrid, where there is an enormous clock and a "Times Square" atmosphere with thousands of people on hand. As the first chime rings out, people all over the nation begin a special welcome to the New Year. With each of the twelve chimes, people eat

Christmas in Spain

(Continued from Page 1)

one grape. Juan says that the type of grape is unimportant and that some who perhaps cannot afford fresh grapes eat raisins. He does not know when or where the tradition began, nor why, just that eating grapes is expected.

Immediately following the last chime, people toast one another with champagne, wishing "Happy New Year," and the air is filled with confetti. And, yes, party goes normally don hats and wave noisemakers.

Shortly after midnight telephone calls may be made to family members who are not nearby. In fact, for most families, New Year's morning calls are much more likely than ones on Christmas Eve.

After midnight those who wish may celebrate with friends. Spanish streets and cafes are full the remainder of the night. Then about eight a.m., people pour into cafes and restaurants for hot chocolate and "chorros," doughnut-type rolls.

The final celebration of the season takes place on January 6, and it is for this moment that everyone has waited and prepared. Christmas Day is but an "appetizer" for the event.

January 6th, termed Twelfth Day or Epiphany in Catholic belief, represents the day on which the Biblical three kings reached Bethlehem and presented their offerings of gold, frankincense, and myrrh to the Child Jesus. To Spanish Catholics, the day is the most important of all.

The Three Kings, called los Reyes Magos (Magic Kings), hold the place of honor in all holiday preparations. Beginning in early December, the three may be found in large department stores talking with youngsters and hearing their whispered wishes. In fact, often both Santa and the Kings are in the same store, filling the same duties. However, after Dec. 24, Santa is no longer to be seen, while the Reyes Magos continue through January 5. As mentioned earlier, Santa does not receive letters from children. Rather, the Reyes are the ones to whom Spanish boys and girls address these requests, but their letters are not sent by mail. Youngsters personally deliver the letters during a visit with the Reyes.

The Reyes Magos, Melchor, Gaspar, and Balthasar (who is always black), are always arrayed in the richest robes and look every bit the part of royalty.

The evening of January 5th witnesses a festival called Cabalgata which honors the three with magnificent parades. Larger cities even televise these ceremonies. First comes a float bearing one Rey, seated upon a large throne attired in rich garments from slipper to turban. He is surrounded by servants, also resplendently garbed, who may cool his majesty by gently waving large plumed fans about the king's head.

Following the king's float is a truck displaying his multitude of beautifully wrapped gifts.

Coming next is the entourage of the king, or his "service," which represents those who serve him. Each of the individuals is also gorgeously attired in Eastern dress and usually rides horseback.

In some cities camels are also part of the cavalcade. Then the floats, trucks, and the entourages of the second and third kings are presented. And, although there may be other floats in the parade, those of the kings are the most important.

Before going to bed on the night of January 5, children carefully place their shoes in the living room before the sofa. Some also leave a cup of brandy or wine for the kings' refreshment, for it is the Reyes Magos who will quietly enter during the night and place each child's gifts on the sofa above his shoes. Tucked into the back of each child's mind is the tradition that only good children receive gifts; those who have been bad receive lumps of coal instead.

Earlier, on Christmas Day, small presents were received, but January 6th is the day for larger gifts such as bicycles. Spanish families bring the holiday season to a close on Twelfth Day by remembering the acts of the Three Kings and exchanging their gifts and their love with one another.



CHRISTMAS Greetings

Celebrating Our 10th Year

900 WHEELER BOX 212 505-482-9030
TEXICO, N.M. 88135

CUSTOM BREAK & SHEAR
TEDSON TRAILERS
TRAILER MANUFACTURING

TED LOPEZ OWNED & OPERATED
505 762-0637 BY TED & SON

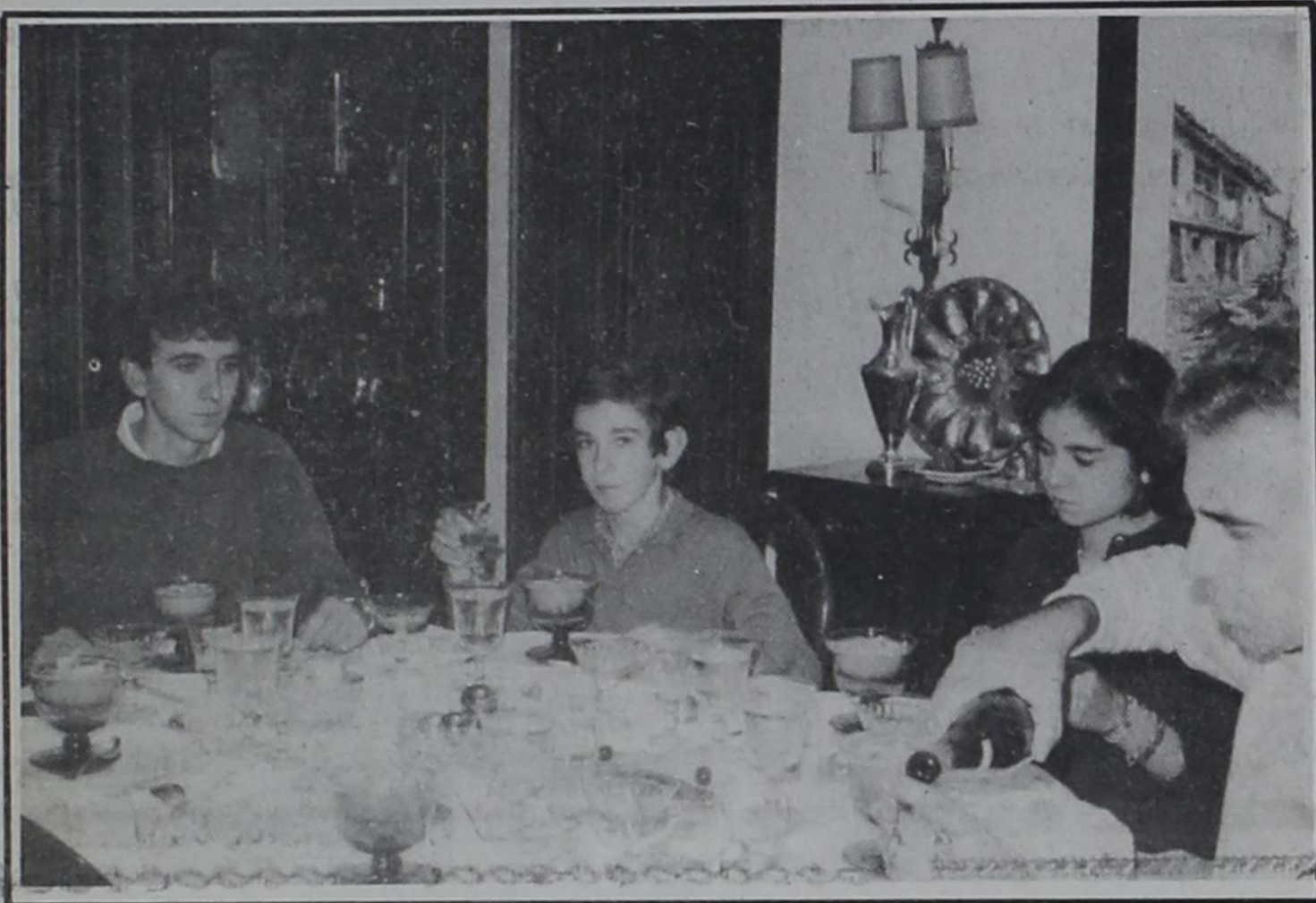

"Christmas, Christmas Time is Here"

Although all meals are somewhat elaborately served in the Rojo home, this Christmas dinner exemplifies the "specialness" of the season. Located in the northern section of Spain, Oviedo is quite near the coast, making seafood abundant and fairly inexpensive. There is no particular meat associated with the holidays in Spain, and the Rojos choose to feast on the bounty of the sea. The darker blue dishes visible in the photo are reserved for seafood. And, although crystal is always used for a meal, Juan's father is shown pouring wine for all present. Most families drink wine with almost every meal, but since Juan's father does not care for the taste of wine, it is served only on special occasions. Pictured left to right are Alfonso, a student of mining engineering; Rafael, a tenth grader; Marta, a pharmacy student; and Senor Rojo, a part time college chemistry instructor, who devotes the rest of his time to running his father's warehouse clothing business with his two brothers. Not pictured are Juan and his mother. Almost hidden by the wine glasses is a small blue and silver Christmas centerpiece.



Doyle, Kathy, Larry & Troy

Holiday Greetings from the new staff at Terra. We invite you to come by and visit with us about your fertilizer, chemical and seed needs for the coming year.

TERRA INTERNATIONAL

481-3219



CHRISTMAS GREETINGS

To Our Good Friends
And Customers
From

**Luce's
Spur
Restaurant**

We Will Close at 3 p.m. Dec. 24th
Closed Christmas Day
Open Dec. 26th
Open New Years Day
Try Our Daily Noontime Buffet

Merry Christmas



from the Board of Directors and Employees
of Deaf Smith Electric Cooperative

From quick doughnuts to chocolate dessert waffle

Casserole

1 lb. ground beef
 1 Tbs. oil
 2 8 oz. cans tomato sauce
 1 6 oz. can tomato paste
 1 cup bouillon
 1 tsp. salt
 1/2 t. Tabasco
 1/2 t. oregano
 1 c. cottage cheese
 8 oz. cream cheese
 1/2 c. sour cream
 1 bell pepper chopped
 8 oz. broad noodles, cooked and drained
 Brown beef in oil. Add tomato sauce, tomato paste, broth, salt, Tabasco, and oregano. Cook 10 min. Remove from heat. Mix cottage cheese, cream cheese, sour cream and green pepper in a separate bowl. Spread half of the noodles in the bottom of a greased 2 quart casserole dish. Cover with cheese mixture, then with remaining noodles. Pour sauce over top.

Bake at 350 degrees for 35 minutes. Serves 4 heartily. Can be made night before or frozen before baking.

Sweet and Sour Meatballs

2 lbs. ground beef
 1 slice bread
 1 egg
 salt, pepper, and seasoned salt to taste
 1 jar chili sauce
 16 oz. cranberry sauce.
 Combine meat, seasonings, bread and egg. Shape into cocktail-size meatballs. Place in a casserole with chili sauce and cranberry sauce. Cover, cook in medium oven 45 minutes. Sounds awful, tastes delicious.

Chocolate Dessert Waffles

1/2 c. butter
 2 squares baking chocolate
 3/4 c. granulated sugar
 1 tsp. vanilla
 2 eggs
 1 1/2 c. flour
 1/2 tsp. baking soda
 1 tsp. cream of tartar
 1/2 c. buttermilk
 1 c. chopped nuts.
 Melt butter and chocolate. Add sugar and beat well. Stir in vanilla. Add eggs, one at a time; beat well. Combine flour, baking soda, and cream of tartar; add alternately with the buttermilk to the first mixture. Then add the nuts and blend well.
 Bake on an electric waffle iron.
 When first taken from the waffle iron, the waffle will be soft, but will become crisp as it cools. These waffles are delicious served hot from the waffle iron with vanilla icecream. Makes 24- 5" waffles.

turning as needed. Shake in a bag of sugar.

Quick French Creams

1 8 oz. pkg. semi sweet chocolate
 1 c. confectioners' sugar
 1 Tbs. milk
 1 egg, well beaten
 1 c. finely chopped nuts or 1/2 c. coconut
 Heat chocolate over hot water until partly melted. Then remove from water and rapidly stir until entirely melted. Add sugar, milk and egg. Beat just to blend. Chill until firm enough to shape. Form into 1/2" balls. Roll in nuts or coconut.

Coconut Cereal Snack

2 c. favorite sweet cereal
 1/2 c. pretzel sticks
 1/2 c. salted nuts
 1 c. coconut
 1/2 c. garlic salt
 1 Tbs. melted butter
 Spread cereal in shallow baking pan. Toast in slow oven (325 degrees) 5 minutes. Add remaining ingredients, mix well, and toast 15-20 minutes or until golden brown. Serve warm or cooled.

'...so I can control people'

Dear Santa Claus,
 How are you doing? Me, I'm fine. I am just writing these few lines to tell you what I want for Christmas: switch around watch, a cowboy skirt with boots and a shirt, and a puppy, a coat, some tennis shoes. I also want a doll and about 20 stuffed animals, and one more thing, for my family and friends to stay well forever.
 Sincerely,
 Eva Jo Alcalá
 Grade 5 Lazbuddie

Dear Santa,
 I want a ten speed bike with hand brakes and gears I can shift, Super Mario Brothers, Gradeous and Lunerpool game pack that I can control, and GI Joe Battleship so that I can have battles, and some Jazz Joy sticks so I can control people on my game.
 Your friend,
 Heath Brown
 Grade 3 Lazbuddie

Dear Santa,
 I hope you come to me. I wanted a doll that talked by my mom could never buy it so I kept on wanting it. So Santa if you can, bring it to me. I will leave some cookies and some milk so that you will feel good, well I have to leave now. I will see you.
 Your friend,
 Anita Aguirre
 Grade 3 Lazbuddie

Dear Santa,
 I want for Christmastime is a three wheeler. I want to give my mom a necklace, but I don't have any money. I guess I have to work for it.
 Sincerely,
 Jerry Martinez
 Grade 5 Lazbuddie

Quick doughnuts
 1 roll refrigerated biscuits
 oil
 Cinnamon and sugar or confectioner's sugar
 Fry refrigerated hot 375 degrees oil until golden brown,

MEMORIES FOREVER
 VHS Video Taping
 Weddings Birthdays
 Special Occasions 8mms to VHS
 Tony and Diane Johnson
 481-3233 481-9277

HOLIDAY GREETINGS

 Karen's
 Special Occasions Farwell
 481-9223

JOYOUS GREETINGS

 Mayor Chris & Peggy Gikas & the staff of the city of FARWELL

Merry Christmas The Beauty Box

 Frances Kube
 Mardee Grisoom
 481-3441



Jackie Smallwood, Sheryl Taylor, Susan Franse & Dr. J.R. Ivins

May this Christmas bring you the music of laughter, the warmth of friendship and the spirit of love

The Farwell Dental Clinic Staff



Greetings to all!

May the warmth of Christmas abide in your home forever.

FRIONA MOTORS
 Parts, Sales & Service
 1011 Grand St. 247-2701

Oldsmobile
 TODAY'S CHEVROLET CHEVROLET
 USED CARS
 FORD Parts & Service
 FORD MERCURY

'I want a baby sister and a remote control train'

The following Letters to Santa came from Mrs. Lynn's first grade class at Texico:

Dear Santa, I am in first grade. I love you. I want My Little Pony and a pink radio.
Love, Christina

Dear Santa, I am in first grade. I love you. I want a Big Foot and a bike.
Jaime

Dear Santa, I love you. I want a Gremlin, Gizmo, and a Santa's Reindeer.
Love, Jeremy

Dear Santa, I am in first grade. I love you. I want a microphone and a cassette player.
Shawn Hall

Dear Santa, I am in first grade. I love you. I want a motorcycle, a robot, and a z28.
Thank you, J.R.

Dear Santa, I am in first grade. I love you. I want a remote control car, and a train.
Thank you, Jake

Dear Santa, I am in first grade. I love you. I want a Freestyle bike and a motorcycle and a blue radio.
Thank you, Josh G.

Dear Santa, I am in first grade. I want a talking Mother Goose and a big

blue bike. I love you. Thank you. Nicki

Dear Santa, I am in first grade. I love you. I want an electric train.
Thank you, Benjamin

Dear Santa, I am in first grade. I love you. I want a doll house and a Cabbage Patch doll.
Tiffany

Dear Santa, I am in first grade. I love you. I want a bike.
Thank you, Timmy

Dear Santa, I am in first grade. I love you. I want a radio, Barbie, and a game.
Hanna

Dear Santa, I am in first grade. I love you. I want a dune buggy. Thank you very much for the dune buggy.
Aaron

Dear Santa, I am in first grade. I love you. I want a baby sister and a remote control train.
Thank you, not signed

Dear Santa, How have you been? I've been fine. Enough talk. Now here is what I want for Christmas. Please send me a grey velvet hat, and a long cowboy coat and a pair of spurs. But the thing I want most is to get out of school!
Sincerely yours, Guy Nickels
Grade 4 Lazbuddie

The best part of Christmas...

The part of Christmas I like best is when we are opening gifts and presents. I like getting toys and clothing. We open our gifts all at the same time. I open the little gifts first and then I open the bigger presents.
by Stephanie Oliveraz

What I like best about Christmas is getting together with my relatives. When we get up in the morning before Christmas, we get dressed and go to Grandma's for lunch. (We usually get up late.) After we get there, we open gifts and eat lunch. Then we head to Granny's house. When we get to opening our gifts, I usually open my presents from the littlest to the biggest.
by Rhae McGuire

The part I like best about Christmas is when I open my presents. It is fun to have new things. I feel happy to have things I've never had before and to get things I wanted that year. I hate to see Christmas go, but there is always next year.
by Jorge Mendoza

The best part about Christmas is when my family gets together, and we open gifts. I like it because we get nice things like toys and clothes. We also give gag gifts. The gag gifts are like old door knobs. The other gifts

are something you can use.
by Kristopher Schwertner

The part of Christmas I like best is when we are together opening gifts. We bring the gifts out. Then we open the little ones first and the big ones last. The way we open them is by age.
by Alma Alcalá

The part of Christmas I like best is when our family opens all their presents, and sees what everybody got them. Everybody gets a hug from me because I love them. After I open the gifts, I play with them. When everyone gets through we eat. After we eat we go home.
by Chase Hardage

The thing I like best about Christmas is when I open my presents. I love playing with them. My brothers will probably break them before the year is over, but I'll play with them while they last.
by Corley White

The part I like best is when we spend a lot of time with our family. We all open presents together. Then we sing Christmas carols and play games.
by Kathy Coronado

The part I like best about

Christmas is when I open my gifts. I like it when I get big things. I always rip open the gifts. I like all the things in my stocking, too. I usually get lots of clothes. I also go to my grandmother's and open lots more presents.
by Jarrod Franse

The part I like best is when my family goes to church. We have a program about baby Jesus. We also sing Christmas songs.
by Melanie Lingnau

The part of Christmas I like best is when we open the presents. We take turns opening presents. I open mine, starting with the biggest first on down to the smallest.
by Ross Stewart

The thing I like best about Christmas is when my family and I take pictures under the Christmas tree. My mom doesn't like to have her picture taken, but we talk her into having at least one picture taken. This year it will be fun taking pictures of my little baby sister, Amanda.

by Veronica Almanza

The thing I like best about Christmas is when I decorate the tree. I also help put presents under the tree. It is fun decorating the tree and putting on the ornaments.
by Melody Pineda

The part of Christmas I like best is putting up the tree. I especially like putting the leaves on. I also like hanging the icicles. To me it is fun.
by Richard Tomlinson

The part of Christmas that I like best is when we decorate the tree. I like this best because we always decorate the tree together. We make pinecone wreaths and popcorn strings. Then, we get to make decorations for the tree. It is lots of fun.
by Georgina Brea Travis

The part of Christmas I like best is getting toys. I also enjoy the dinners we have. It's also special because that's when Baby Jesus was born.
by Duane Haseloff

YULETIDE CHEER



Crossroads Motel
Turquoise City
Wholesale And Retail
Gift Shop

Hiway 60-70-84, Texico Juanita Hardage 482-3374

Big Country Ford & Subaru is proud to announce that

Ricky Bennett

is now associated with us as a sales representative.



HAGELGANTZ
BIG COUNTRY FORD & SUBARU
2400 MARRY DRIVE 762-3427

MERRY CHRISTMAS

JOY TO ALL
Thanks for being such dear customers. We're proud to serve you.



De'Aun Willoughby
Certified Public Accountant

Farwell, Texas 481-9150

Rejoice! The Savior is born! Let each of us spread His message of love and peace this Christmas season. Good will to all!



"Compare - Then Decide"

Hundreds of People Have Driven to Portales And Saved Thousands

TEAGUE STREBECK
Motor Company

Ford • Mercury • Chrysler • Plymouth • Dodge

AUTHORIZED SALES • SERVICE • PARTS

REPAIR ON ALL MAKES AND MODELS
COMPLETE WRECKING & TOWING SERVICE

CLOVIS 762-3845	ON CLOVIS HWY IN PORTALES (1115 N. CHICAGO) PORTALES, N.M.	PORTALES 356-8584
---------------------------	---	-----------------------------

Merry Christmas



and please accept our sincere thanks for giving us the pleasure of serving you.

Juanito's Mexican Restaurant

Tues-Sat: 11 a.m. - 9 p.m.; Sunday: 11 a.m. - 2 p.m.
Closed Mondays

1608 Mabry Drive 762-7822

Engram looks back on the old days

Ted Engram was born 77 years ago - before New Mexico became a state. His parents were William Wesley Engram and Elizabeth Anthony Engram. He had three sisters and one brother. "We didn't know anything to do but work in those days," said Engram. The Engram family grew maize, broom corn, and a little corn. In those days farmers tried to be self sufficient, so they had farm animals to tend. The Engram family sold the broom corn they grew to a broom factory in Farwell. "A blind man named Mr. Fletcher made the brooms," said Engram. Engram walked to Locust Grove school as a boy, and later to Texico School after consolidation. "We went to a one room school at first. We went when we could get there, which wasn't all the time. But if you walk

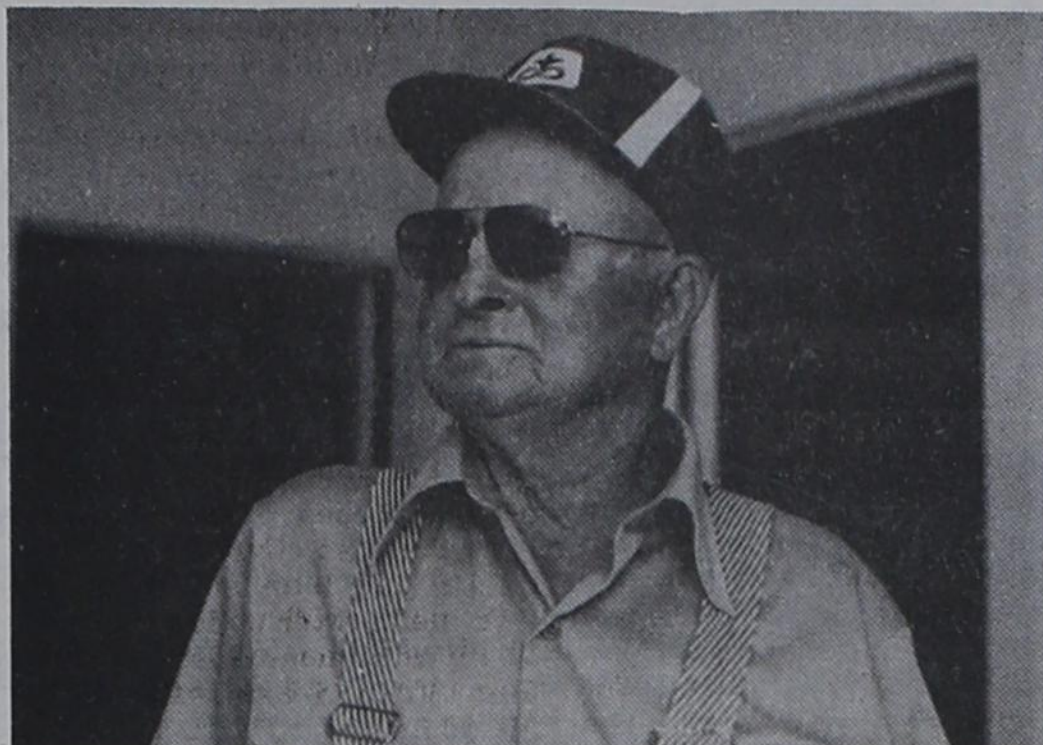

Edward "Ted" Engram

I remember the day because a boy pushed me off the front of the building, and I broke my collarbone. I was only about six years old. The boy was one of my neighbors; he was just a kid, too," said Mr. Engram. In 1930 Mr. Engram married his wife, Linnie Engram, in Texico. They have three children, Patsy White, Jo Beth Williams, and Donald Ray Engram. They farmed in this area and in Hub for 9 years. "I've seen a lot of changes in farming over the years. Farmers are a lot more careful about the soil now. Back then half of it blew away. They didn't realize what the blowing was doing to their land," says Mr. Engram. Economic conditions were bleak in this area in the Dust Bowl Era. "I've worked for 50 cents a day," says Engram. During the late 1930's and 1940's the Engrams moved to Colorado where Engram mined and did construction work. "The hard rock mines there were not as bad as the coal mines," says Engram. "We did a lot of blasting, and then shoveled it out by hand," says Engram. Engram worked for \$4 per day in Colorado, but he could rent an eight room home for \$5 per month. The Engrams moved back to the Twin Cities in 1970. "The climate may be rough here at times, but over all this is a good place to be," says Engram.

'Pd like a real horse

The following letters are from Mrs. Dunsworth's first grade:

Dear Santa, I have been good. I love you, Santa. I am in the first grade at Texico. Please bring me a racetrack with jumper cars.

Love, Kyle Mayfield

Dear Santa, I have been good. I love you, Santa. I am in first grade at Texico. Please bring me a four wheeler and a freestyle bike. I will bring you cookies.

Love, Stevin Eric Stanley

Dear Santa, I have been good. I love you, Santa. I am in the first grade at Texico. Please bring me a dirt bike.

Love, Michael Rivera

Dear Santa, I have been good. I love you, Santa. I am in the first grade at Texico. Please bring me a watch and a bike.

Love, Amanda Munez

Dear Santa, I have been good. I love you, Santa. I am in the first grade at Texico. Please bring me a skateboard and a bike.

Love, Sam Singleterry

Dear Santa, I have been good. I love you, Santa. I am in the first grade at Texico. Please bring me a real horse and a single waterbed.

Love, Jason Meeks

Dear Santa, I have been good. I love you, Santa. I am in the first grade at Texico. Please bring me a three wheeler.

Love, David Scioli

Dear Santa, I love you Santa. I am in the first grade at Texico. Please bring me a rocking horse. I have been good. I will leave you some cake and cookies.

Love, Stephani Chancy

Dear Santa, I have been good. I love you, Santa. I am in the first grade at Texico. Please bring me a real puppy. You can see how good I've been.

Love, Tobe Dias

Dear Santa, I have been good. I love you, Santa. I am in the first grade at Texico. Please bring me a Teddy Ruxpin. I will leave you some cookies.

Love, Shauna Duncan

Dear Santa, I have been good. I love you, Santa. I am in the first grade at Texico. Please bring me a tape player.

Love, Dustin Whitener

Dear Santa, I'm trying to be good. I love you, Santa. Please bring me a four wheeler and a walkie talkie.

Love, Kyle Cain

Dear Santa, I have been good. I love you, Santa. I am in the first grade at Texico. Please bring me a Mickey Mouse watch.

Love, Beatris Trillo

Dear Santa, I'm trying to be good. I love you. Please bring me a walkie talkie and a remote control car.

George Ortiz

four miles to school, you must really want to be there," he said.

"We played all kinds of games kids wouldn't play now," said Engram. They had to make up games or toys. They played one game called "Flinch" that Mr. Engram remembers. There were definitely not any card games played in the Engram household. Obviously, there were no video games or computers or laser tag games in those days.

"Christmas back then was not what it is today," said Engram. There was not as much commercialism. It was more of a family and religious holiday in those days.

Church played a major part in the lives of early settlers in this area. Engram and his mother and older sisters were baptized in lakes in this area.

Engram remembers Texico and Farwell as thriving communities in his childhood. "I remember when the Texico Hotel was built, and I remember when the Parmer County Courthouse was dedicated in 1916.

"They had a big to do when the courthouse was dedicated.

JOY
Electronic Parts of Clovis
1600 Mitchell 762-3181

Merry Christmas & Happy New Year

Thank you for making our first year a success.

K&J Video
Kent, Joyce, Nash & Tyler

CHRISTMAS JOY

Here's hoping Saint Nick brings you and your loved ones much good luck and happiness this Christmas.

Lee's Electric The Hutchins Family

Needed numbers

For Farwell Fire Department, ambulance, Parmer County sheriff and Texas state police - 911 (in city) or 481-3303 (in country area).
Texico fire department, ambulance or Texico city marshal - 763-3482.
New Mexico state police - 763-3426.
Curry County sheriff - 769-2335.

Open House

Honoring **JANIE BOWERY**

Who is retiring after serving as Farwell City Clerk for the past 25 years.

Friday, Dec. 31
Farwell City Hall

Come visit anytime during the day.

REJOICE in the beauty of this Holy Season.

LOOMIX
LIQUID STOCK FEED SUPPLEMENTS

481-3339

Peace on Earth

May you and your loved ones have a safe and joyous Holiday Season, a healthy and prosperous New Year!

ALLAN HAILE
Frona, Texas 247-2734

Like a good neighbor, State Farm is there.

STATE FARM INSURANCE COMPANIES, Home Offices, Bloomington, Illinois

BEST WISHES

PIERCE REAL ESTATE
482-9188
TEXICO, N.M.

CHARLOTTE PIERCE, BROKER
512 Wheeler Ave.
Texico, N.M.
[505] 482-9188

Fully Licensed
In New Mexico & Texas

Greetings

May every home be filled with the peace that Christmas brings.

We want to thank all our customers in the Farwell area for their business.

Pump Sales & Service
P&R Surge Valve Sales
Welding Machine Work Parts

BOVINA PUMP CO.

1100 W Hwy 86 Bovina 238-1596

Merry Christmas

One of the special pleasures of Christmas is the opportunity to greet one's friends and customers - with appreciation of our cordial relations.

WASTE CONTROL OF NEW MEXICO

482-9211

OWNERS RALPH BALFANZ
and JAMES CARMACK



CARMACK & SONS, INC.
314 MAIN CLOVIS, N.M.
"The men's store where women like to shop"

El Monterrey
Restaurant
MEXICAN FOOD EXCLUSIVELY
SINCE 1934



SERVING MONDAY
THRU SATURDAY
11:00 - 2:00
4:30 - 8:30
CLOSED SUNDAY
ORDERS TO-GO
WELCOME NEWCOMERS -
763-4031

Quality Groceries
Stansells Thriftway
1 Highland Shopping Center

Meat Cut To Order
Phone 763-5122

QUALITY DEPENDABILITY
ZIA BATTERY OUTLET
SALES AND SERVICE
RETAIL AND WHOLESALE
Carmel & Alice Huggins
408 North
CLOVIS, NM 88101



TRIANGLE
mini mail
2400 North Prince - Phone 762-3301 - Clovis, N.M.
Service with a personal touch

STATE FARM
INSURANCE
816 FIVE STREET
CLOVIS

BUS. 762-2822
OR 762-2133
RES. 762-2189

RODNEY "Rod" BURNS
AGENT
PROMPT, PERSONAL SERVICE
State Farm Insurance Companies

"Where Fashion Lives"
Queens n' Teens
500 Main, Clovis • (505) 763-7153

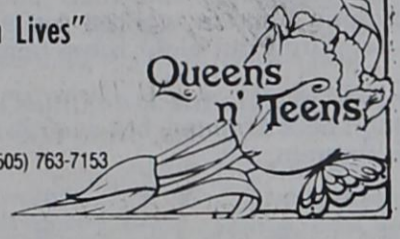

Merry Christmas

**These Clovis Businesses
Wish You A Very Merry
Christmas And Extend
Their Thanks For Your
Patronage This Past Year.**

*"Deck the
boughs"*



40 years in the same location
Clovis Safety Lane
516 W. 7th
763-7777



LAMP SHADES & CLOCK REPAIR
Lonnie & Alice May
821 Main 762-0516

VILLAGE PAWN & GIFT
N. Mex Souvenirs - Indian Crafts/
Gifts & Turquoise
Pawn Loans
Phone: (505) 769-0191
609 Main In The Village

New Holland, Inc.
2300 Mabry Drive, Clovis
(505) 762-3777



COMPLETE INSTALLATION SALES & SERVICE
ALL TYPE OF SCALES - WORK GUARANTEED

TAYLOR SCALE CO.
FAST DEPENDABLE SCALES SERVICE

James D. Taylor 3721 E. 21st St.
763-4852 Clovis, NM

LARUE JEWELRY AND MFG.
DOYAL G. LARUE

102 WEST FIFTH ST. TELEPHONE 763-3354
CLOVIS, NEW MEXICO 88101

COPIES AND MORE
Dealers for Savin & Toshiba copiers,
Panasonic & Brothers typewriters
& Frieden mailing equipment
500 Mitchell 769-2391

Stork Shop
"Where Life Begins in Style"
Infants & Maternity Wear
1312 Main 763-7145



BALDOCK & SONS', INC.
1621 N. Prince 763-4425

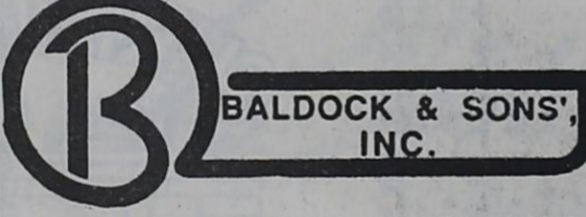

Vela's Concrete Co. & Ready Mix
S. of Clovis 762-3917



McDonald's 14th & Mitchell
Clovis 505/762-0291
Free ornament with \$5 gift certificate



Merry Christmas and thanks for your patronage.
Evans Jewelry
416 No. Main 762-0410

**Freeman's
Bridal Shop
& Formal Wear**
510 Main 762-0474

House Plants • Shrubs • Trees • Roses
**The Green Thumb
Nursery & Garden Shop**
3608 N. Prince (505) 762-9479
Clovis, N.M. 88101 Dale & Judy Vaughan
Owners

FITZ SHEET METAL
HEATING - AIR CONDITIONING
SALES - SERVICE - INSTALLATION
713 COMMERCE WAY - CLOVIS, N.M.
PHONE 505 - 763 - 6915
**WOOD STOVES
& ACCESSORIES**

PONTIAC GMC TRUCKS GMC
JONES-PONTIAC-GMC, INC.
Hwy 60-70-84E, Clovis (505) 762-2986

ALL PARTS SUPPLY
OVERNIGHT DELIVERY ON ITEMS NOT IN STOCK

Parts For Everything That Moves! **NAPA** Complete Machine Shop Service

CORNER OF SECOND & GIDDING 763-5524

BOB'S UPHOLSTERY, INC.
1105 THORNTON
CLOVIS, NM 88101
(505) 762-7836
JOHN THORNTON



McDANIEL'S
YOUR WALL TO WALL STORE
Furniture and Floor Covering, Inc.
1020 Main 762-4481 1013 Mitchell 763-7940

Zia R/C HEADQUARTERS
PLANES, CARS, BOATS,
TRAINS & PLASTICS,
DREMEL & X-ACTO TOOLS
(505) 762-4340
1006 MAIN
CLOVIS, N.M. 88101



WALTER'S CARPET
Carpet, linoleum, Formica, ceramic, tile
200 E. 21st 762-9217
Walter Smith

Enjoy **Coca-Cola**
Trade-mark (C)
Clovis
Coca-Cola
Bottling Co.



418 Main St. - Ph. (505) 763-6516 - Clovis, N.M.
Authorized Service Parts For...
Maytag, Gibson, Tappan
Admiral, United, Refrigerators and Freezers
Meyers Refrigeration & Appliance Service
Frank Meyer - Owner
Repairs & Parts for Most Brands of Appliances
1105 Main Phone: 505/763-6873
Clovis Emergency: 762-5101

**Hosanna
Christian Book Store**
Bud & Phyllis Queener 311 Main Street
Phone (505) 762-1691 Clovis, N.M. 88101

BIG O TIRES
RADIALS-60 SERIES
MAGS-CHROMES-SHOCKS
BRAKES-ALIGNMENT
520 E. 1st Clovis



DR. LAWRENCE J. GREGORY
CHIROPRACTOR
TELEPHONE
OFFICE (505) 763-6948 3001 NORTH PRINCE ST.
HOME (505) 762-1265 CLOVIS, N. M. 88101

MARCOS DORIS
Furniture LAND
Quality At Reasonable Prices
115 WEST GRAND
PHONE 762-1111 CLOVIS, NM 88101



HUNKER ABSTRACT COMPANY
304 RENCHER
CLOVIS, NEW MEXICO
TELEPHONE 762-4537
ABSTRACTS BERNARD HUNKER
TITLE INSURANCE OWNER

Travel Center
Your American Express office
121 W. 7th St. 762-4566

EPPSCO 720 Tatam
769-1961
SUPPLY COMPANY



"Fast Reliable Service"
EASTWOOD CONSTRUCTION CO.
 "Serving the Southwest Since 1947"
 NM LIC. # 7818

Office: 604 Hull St. - Clovis
 Mailing: 2717 Gidding St.

• ASPHALT PAVING
 • RESURFACING
 • HEAVY EQUIPMENT & HOURLY RATES

• DIRT EXCAVATION
 • FEED PENS
 • FILL & SITE WORK

IT ALL STARTS HERE!

The price... the service... the satisfaction.

HAGELGANTZ
 BIG COUNTRY FORD & SUBARU
 2400 MABRY DRIVE 762-4427

WE TRADE AND SELL PAPERBACK BOOKS
 GIFTS FOR ALL OCCASIONS
VHS movie rentals (7 days a week) - 99¢

Talico
 Gift Shop & Book Exchange

1301 N. PRINCE CLOVIS, N.MEX. 88101
 PHONE (505) 763-7720

COOKE CABLEVISION INC

600 Main 763-4411

LARRY'S
 Hobby - Craft & Specialties
 Tandy Leather
 R/C Cars

405 Main Downtown 769-1441
 Clovis, NM

**alls with
 s of holly... 'Tis the season to be jolly...**

LET HARMONY ON
 EARTH, PEACE FOR ALL
 MANKIND AND PLEASANT
 THOUGHTS OF FRIENDS
 PREVAIL, MAKING
 THIS JOYOUS NOEL ONE
 OF BEAUTY AND
 PROSPERITY.

Muffley Funeral Home

1430 Thornton
 Clovis, New Mexico

Russell and Carolyn Muffley

**AAA FIREPRO
 EQUIPMENT & SUPPLY**
 Fire & Safety Equipment
 Janitorial Supplies
 Allen Isbell, Owner

113 N. Main 762-2594

Happy Holidays

SPS

500 Pile
 763-4481

**OUT ON A LIMB
 SHOT'S TREE TRIMMING
 WILL DO IT RIGHT**

FREE ESTIMATES 762-0060

Snyder's *Wiley & Lois Snyder*
 Your Fabric Care Center
 Monogramming
 Shirt & Jean Service
 Dry Cleaners
 Expert Alterations

2211 N. Prince 762-7667
 21st & Thornton 762-7304

TOYOTA LINCOLN • MERCURY

Watson Motor Co.
 600 W. 7TH
 CLOVIS, NM 88101

Gary Lancaster Sales Manager
 Bus. 762-4551
 Res. 769-0486

Gas Company of New Mexico
 Serving Texico & Clovis
 320 Connelly 762-3371

FRAME & ART
 • Custom Framing •
 • Art Supplies • • Frames •
 • Designer Mats •
 Sharlene Lynch, Owner
 Member PFFA
 505/763-5714 1713 W. 21st

THE BARKING LOT
 Professional All Breed
 Dog Grooming
 Hollywood Trained
 16 years at same location
 1211 Main Street
 762-5622 for Appointment

THE SHOE STRING
 DRESS YOUR ENTIRE FAMILY
 IN NEARLY NEW FASHIONS

919 Main St.
 Clovis, N. M. 88101
 Bonita Tanner (505) 762-5210

PHOTO WORLD
 Next-Day service
 Pictures copied
 Dixi Martin
 762-5353 801 N. Prince

Clovis Body Shop
 DAVID DEATON
 President
 2024 S. Prince - Box 163
 Clovis, New Mexico 88101
 Phone (505) 763-3447

MABRY MOTOR CO.
 110 S. Hickory
 We Buy Clean Used Cars
 Elmer Coffey Office ph: 762-3111
 H.R. Trent, off. mgr. Res. Ph: 762-0860
 Your Business Appreciated

Family Pharmacy
 1801 W. 21st 762-4579

BOYD'S BRAKE & ALIGNMENT SERVICE
 39 YEARS IN CLOVIS
 • CUSTOM MUFFLER INSTALLATION
 • PROFESSIONAL DISC & DRUM TURNING
 Ray Boyd 1605 Mabry Drive
 763-4326 Clovis, NM

A Unique Book Store
THE ENCHANTED SUNMARK
 1208 PILE CLOVIS 762-2044

BELTONE
 Hearing Aid Service
 1305 Thornton 762-7992

Guy's Electric Co
 COMPLETE ELECTRIC SERVICE
 COMMERCIAL • RESIDENTIAL
 ONE OF THE NEWEST AND FINEST SHOWROOMS IN CLOVIS
 LICENSE NO 11629 - BONDED - INSURED
 217 Sycamore - Clovis - 762-5853

Serendipity Roadrunner Engravers
 TROPHIES - AWARDS
 PLAQUES - GIFTS
 CUSTOM DEIGNED AND
 MANUFACTURED IN OUR SHOP
 LASERWORK - PLASMA CUT
 BEVELS, STEEL & BRASS PLAYS
 REPRODUCTIONS IN METAL
 OF YOUR LOGOS, LETTERS, SIGNS AND ETC.
 ARCHITECTURAL & COOL SIGNS

763-6020 312 MAIN • CLOVIS

International Tours® of Clovis
 Complete Business & Pleasure Travel Services
 501 Commerce Way, Suite 6
 Clovis, New Mexico 88101 (505) 763-3486

PRUIT TV
 1310 Main 762-7729

Highland Drug Store
 2905 N. Main 762-2935

Steve Baldock's Music Note
 416 1/2 Main / (505) 762-6775
 Clovis, N.M. 88101

Medco Medical
 24 Hour Emergency Service
 Everything you need for the Home
 In Medical Care and Supplies.
 Medco Medical
 121 W. 5th
 Clovis, NM 88101
 505-762-2964

Clovis Furniture Center
 Don & Ora Krause
 101 Pile, Clovis

FARM BUREAU INSURANCE
 Troy, Ty & Oliver
 1516 Thornton 762-4729

HOWARD & SONS, INC.
 Star Route - Box 29-A
 CLOVIS, NEW MEXICO 88101
 (505) 762-0192 or 769-1516

L. K. Howard, Sr.
 Res (505) 763-6476

There's MORE TO LOVE
 A WOMEN'S PLUS SIZES BOUTIQUE
 In the heart of downtown Clovis
 9:30-5:30 Mon. Sat.
 Evenings by appointment
 519 MAIN 762-9224

Edward D. Jones & Co.
 Established 1871
 Members New York Stock Exchange, Inc. SIPC

BOB WATERS
 INVESTMENT REPRESENTATIVE

716 MITCHELL
 P. O. BOX 59
 CLOVIS, N.M. 88101
 PHONE (505) 762-4479

Hamburgers & Hotdogs

W
 Wenerschnitzel
 13th & Main
 Clovis, N.M.

Raspberry Rhapsody, Divinity...and more

Pecan Pie
 1/2 c. sugar
 4 Tbs. butter
 vanilla
 1/2 c. chopped pecans
 1 c. light corn syrup
 3 eggs
 unbaked pastry shell
 Bring sugar, syrup and butter mixture to a boil. Beat eggs. Mix a tiny amount of the hot syrup into the eggs. Gradually add the hot syrup a drop or two at a time so that you do not scramble the eggs. Flavor with vanilla. Add chopped pecans. Pour into unbaked pie shell. Bake at 350 degrees for about 30 minutes.
 by Cynthia Thigpen

Milky Way Cake
 8 Milky Way bars (regular size)
 2 sticks oleo
 2 cups sugar
 4 eggs
 2 1/2 c. flour
 1/2 tsp soda
 1 1/4 c. buttermilk
 1 c. pecans
 Melt Milky Way bars and 1 stick of oleo in top of double boiler. Cream together sugar and one stick of oleo. Add beaten eggs, flour, soda, and buttermilk. Then add candy bars and pecans. Bake in a tube pan 1 hour and 15 minutes at 325 degrees.
 Frosting for Milky Way Cake
 2 1/2 c. sugar
 1 c. canned milk
 1 c. marshmallow creme
 1 (6 oz.) pkg. chocolate chips
 1 stick oleo
 Cook sugar, milk, and marshmallow creme until it forms a soft ball in cold water. Then add the chocolate chips and oleo. Stir until melted. Spread on cake.
 by Cynthia Thigpen

Hot Punch
 1 qt. cranberry cocktail
 1 c. sugar
 1-6 oz. can frozen orange juice
 1-6 oz. can frozen lemonade
 4 qts. water
 1 c. cinnamon red hots
 2 whole cloves
 Mix ingredients and put into a coffee urn - putting the red hots and cloves into the basket. Let it perk.
 by Cynthia Thigpen

Divinity
 4 c. sugar
 1 c. light corn syrup
 3/4 c. water
 1/8 tsp. salt
 3 egg whites
 1 tsp. vanilla
 1/2 c. chopped pecans
 Combine sugar, corn syrup, water and salt in a 2-quart saucepan. Cook over medium heat until mixture reaches hard ball stage (260 degrees).
 Cheese Crisps
 1 c. butter softened
 2 c. shredded sharp cheese
 2 c. flour
 1/4 tsp. hot sauce
 1/4 tsp. salt
 2 c. crisp rice cereal
 Combine first five ingredients. Mix until well blended. Gently stir in rice cereal. Shape into walnut sized balls. Place on an ungreased cookie sheet. Flatten with a fork. Bake at 350 degrees for 10 minutes.
 by Cynthia Thigpen

While syrup cooks, beat egg whites until very stiff. Gradually pour hot syrup over egg whites and continue beating at high speed until mixture is thick and candy starts to lose its gloss. The beating will require about 12 minutes. Add vanilla and nuts to candy and drop by teaspoonfuls onto wax paper. Makes about 7 doz pieces.
 Note: Apricot divinity may be made by adding 1(3 oz.) package apricot gelatin to the egg whites before beating.
 by Cynthia Thigpen

Hummingbird Cake
 3 c. flour
 2 c. sugar
 1 tsp baking soda
 1 tsp. salt
 1 tsp. cinnamon
 3 eggs, beaten
 1 c. vegetable oil
 1 (8 oz.) can crushed pineapple, undrained
 1 c. chopped pecans
 2 c. mashed bananas
 cream cheese frosting (below)
 1/2 c. chopped pecans
 Combine dry ingredients in a large mixing bowl. Add eggs and oil, stirring well until dry ingredients are moistened. Do not beat. Stir in vanilla, pineapple, 1 c. pecans, and bananas.
 Spoon batter into three greased and floured 9 inch round cake pans. Bake at 350 degrees for 25-30 min. or until a wooden pick comes out clean. Cool in pans 10 minutes; remove from pans and cool completely.
 Spread frosting between layers and on top and sides of cake; then sprinkle 1/2 c. chopped chopped pecans on top.
 Cream cheese frosting to go with cake above

Broccoli Casserole
 3 10 oz. pkg. chopped broccoli, cooked
 1 stick margarine
 4 Tbs. flour
 1 1/2 Tbs. powdered chicken stock
 2 c. milk
 2/3 c. water
 2/3 c. herb seasoned stuffing (I use Pepperidge Farm)
 2/3 c. chopped walnuts or pecans
 6 Tbs. butter
 Cook and drain broccoli. Put in greased casserole. Melt margarine, blend in flour and dry chicken stock. Add milk making a light gravy. Pour over broccoli.
 Heat water and margarine. Add stuffing, blend, and then add walnuts and sprinkle over casserole for topping. Bake at 400 degrees for 20 minutes. Delicious.
 by Ardith Bruce

Festive Cranberry Salad
 4 c. fresh cranberries, ground
 1 large orange, unpeeled and seeded, and ground
 1 c. sugar
 1 3-oz. pkg. lemon Jello
 1 envelope unflavored gelatin
 1 c. boiling water
 1 15-oz. can crushed pineapple, undrained
 1 c. chopped nuts
 1/2 c. diced celery
 Combine cranberries, ground orange, and sugar. Chill one hour.
 Dissolve both Jello and gelatin in boiling water. Stir in cranberry mix, pineapple, nuts, and celery.
 Let gel in a 5 cup mold until firm. Unmold and serve.
 by Ardith Bruce

Raspberry Rhapsody
 1 1/2 c. flour
 3 Tbs. sugar
 3/4 c. soft margarine
 1/3 c. chopped nuts
 1 (8 oz.) pkg. softened cream cheese
 2/3 c. sugar
 12 oz. whipped topping divided in half
 2 pkg. (3 3/4 oz.) vanilla or French vanilla instant pudding mix.
 1 1/2 c. milk
 1 pkg. (10 oz.) raspberries, thawed and drained.
 fresh raspberries (optional)
 Combine flour and 3 Tbs. sugar in a mixing bowl. Cut in margarine until mix resembles coarse meal. Stir in chopped nuts. Press mix into a 9x13x2" baking dish and bake at 350 degrees for 15 min. Cool completely.
 Combine cream cheese and sugar and beat until blended and spread over cooled crust. Chill.
 Combine pudding mix and milk. Beat 2 minutes on medium speed of mixer. Fold in drained raspberries and spread mix over cream cheese layer. Spread remaining topping over pudding layer. Garnish with fresh raspberries or additional nuts if desired. Chill before serving in squares.
 by Ardith Bruce

Broccoli Casserole
 3 10 oz. pkg. chopped broccoli, cooked
 1 stick margarine
 4 Tbs. flour
 1 1/2 Tbs. powdered chicken stock
 2 c. milk
 2/3 c. water
 2/3 c. herb seasoned stuffing (I use Pepperidge Farm)
 2/3 c. chopped walnuts or pecans
 6 Tbs. butter
 Cook and drain broccoli. Put in greased casserole. Melt margarine, blend in flour and dry chicken stock. Add milk making a light gravy. Pour over broccoli.
 Heat water and margarine. Add stuffing, blend, and then add walnuts and sprinkle over casserole for topping. Bake at 400 degrees for 20 minutes. Delicious.
 by Ardith Bruce

Festive Cranberry Salad
 4 c. fresh cranberries, ground
 1 large orange, unpeeled and seeded, and ground
 1 c. sugar
 1 3-oz. pkg. lemon Jello
 1 envelope unflavored gelatin
 1 c. boiling water
 1 15-oz. can crushed pineapple, undrained
 1 c. chopped nuts
 1/2 c. diced celery
 Combine cranberries, ground orange, and sugar. Chill one hour.
 Dissolve both Jello and gelatin in boiling water. Stir in cranberry mix, pineapple, nuts, and celery.
 Let gel in a 5 cup mold until firm. Unmold and serve.
 by Ardith Bruce

Raspberry Rhapsody
 1 1/2 c. flour
 3 Tbs. sugar
 3/4 c. soft margarine
 1/3 c. chopped nuts
 1 (8 oz.) pkg. softened cream cheese
 2/3 c. sugar
 12 oz. whipped topping divided in half
 2 pkg. (3 3/4 oz.) vanilla or French vanilla instant pudding mix.
 1 1/2 c. milk
 1 pkg. (10 oz.) raspberries, thawed and drained.

GREETINGS OF THE SEASON



Bringing old-fashioned wishes of Christmas joy.

I.W. "Dutch" Quickel
Insurance Sales & Service
 303 Ave. G Farwell 481-3474

'I want a jambox'
 Dear Santa,
 I wish I could have a pair of high toops and a gun for Christmas. I wish I could have a set of markers, a pair of boots and a pair of spurs.
 Your friend,
 Jerry Doshier
 Grade 3 Lazbuddie

'I want a jambox'
 Dear Santa,
 I wish I could have a pair of high toops and a gun for Christmas. I wish I could have a set of markers, a pair of boots and a pair of spurs.
 Your friend,
 Jerry Doshier
 Grade 3 Lazbuddie

'I want a jambox'
 Dear Santa,
 I wish I could have a pair of high toops and a gun for Christmas. I wish I could have a set of markers, a pair of boots and a pair of spurs.
 Your friend,
 Jerry Doshier
 Grade 3 Lazbuddie

Rejoice



... and his name shall be called... The Prince of Peace." Isaiah 9:6

Wynona and Floyd Coates
Farwell Farm Supply

season's best



We wish you a season of beautiful Christmas moments... lasting memories to treasure always.

The Byrd Family
 Ronald and LeAndra
 Chad and Quinn

Holy Night



A time to gather together in celebration of the meaning of His birth and the beauty of His love... this is the true spirit of Christmas.

Eastern New Mexico Rural Telephone Cooperative

'I hope the reindeer are not sick'

Dear Santa,
I'm trying to be good. I love you, Santa. Please bring me a bike and a train set.
Vincent Varela

Dear Santa,
I'm trying to be good. I love you, Santa. Please bring me a bike and a stereo.
A. Espinoza

Dear Santa,
I'm trying to be good. I love you, Santa. Please bring me a four wheeler and a radio set.
Phillip Ortiz

Dear Santa,
I'm trying to be good. I love you, Santa. Please bring me a Mrs. Santa Claus doll and a Rudolph.
Beth Morris

Dear Santa,
I'm trying to be good. I love you, Santa. Please bring me a pink watch with a dog on it and a belt.
Linda Haney

The following letters are from Farwell's first grade:

Dear Santa,
I want you to buy me a big airplane and a cassette player.
Thank you,
Robert

Dear Santa,
I am six years old and I am in Mrs. Roberts' first grade class. For Christmas I want a duck Puffalump, a jewelry box, some make-up and some Get in Shape Girl stuff. My two bottom teeth are gone. I am going to put them under my pillow tonight. I want a pound puppy watch, too. Thank you.
Merry Christmas,
Ginger Sides

These letters are from Texico second graders:

Dear Santa,
How are you doing? My name is Kelli. How are the reindeer? I hope the reindeer are ready for a trip. I want some Barbie dolls.
Your friend,
Kelli Roach

Dear Santa,
How are you Santa? How are your reindeer? How is Rudolph? I want a walkman and a turbo-hopper and a watch. Have a nice trip.
Love,
Ronnie Clark

Dear Santa,
Hi Santa. How are the reindeer this Christmas? I want a transformer car for Christmas. How are you this Christmas? Are the reindeer ready for the trip?
Love,
Carl Smith

Dear Santa,
We've moved. How are your reindeer doing? How is Mrs. Santa Claus and you, Santa Claus? I want a bike. I love you Santa, and are you ready to go?
Love,
Kara Kittrell

Dear Santa,
How are you doing? How are your reindeer? I want a baby Cabbage Patch Kid. My sisters want a baby Cabbage Patch Kid and a baby brother. I miss you and the reindeer and Mrs. Claus.
I love your family,

Cimeri Parks

Dear Santa,
How is Mrs. Claus and the reindeer? I hope you have a happy Christmas. I want a keyboard and a bike, Cricket, Corky, and some skates, and Barbie and the Rockers, and a big Christmas bear and a little Christmas Bear.
Love,
Eva Maxwell

Dear Santa,
I hope that none of the reindeer get sick. Also, I hope you don't get sick because I want a good Christmas. But, if none of the reindeer get sick, you won't get to come for Christmas. I would like some dinosaurs. I live on 220 Lamar.
Love,
Tracy Montgomery

Dear Santa,
How are your reindeer? How is Mrs. Claus? I want Cricket and a Baby Heather, and I want Corky, and I want a keyboard. I want Jill and Barbie and the Rockers and some clothes.
Love,
Marsha Marlow

Dear Santa,
How is Mrs. Claus? I live at 305 Avenue D. Christmas is on the 25th. I want a Transformer and a Gobot. I love you, Santa. I want a XT7.
Love,
Chad Lasiter

Dear Santa,
Is Rudolph ready for that big ride? Can I have a turbo-hopper? Is Mrs. Santa O.K.? I want a freestyle bike. I hope the reindeer are not sick.
Love,
Pecos Chumley

Dear Santa,
I want a Barbie House and a Barbie Swimming pool. I have been good.
Love,
Lindsey Burford

Dear Santa,
How is Mrs. Claus? How is Rudolph and how are you? For Christmas I want a Jem doll

Dear Santa,
How is Mrs. Claus? How is Rudolph? Is he ready for Christmas? How is Mrs. Claus? Santa, my brother wants a bike for Christmas. Santa, I want a Bigfoot that has cars that smash.
Love,
Neal Hall

Dear Santa,
How are you and Mrs. Claus? You are very nice, I bet. I want a doll named Baby Heather. I want a baby brother. I know you can't bring me a brother.
Love,
Karen

Dear Santa,
How is Mrs. Santa? How is Rudolph and how are you? For Christmas I want a Jem doll

How are you and the reindeer and Mrs. Claus? I want a Natedo for Christmas. My mom wants a new car and my dad wants a new VCR for Christmas. Have a merry Christmas.
Love,
Dominic Gutierrez

Dear Santa,
How are you and your wife? How is Vixen? I would like My Child and a Pound Puppy and a stroller and two real rings and a necklace for my mom with a diamond, and a shovel for my dad.
Love,
Shannon Null

Dear Santa,
How are you doing? Do you like your reindeer? How are they doing? I want a bike. I like Christmas so much. How is Mrs. Santa Claus? I want a toy truck. I want a train set.
Love,
Tobie Askew

Dear Santa,
How is Rudolph? Is he ready for Christmas? How is Mrs. Claus? Santa, my brother wants a bike for Christmas. Santa, I want a Bigfoot that has cars that smash.
Love,
Neal Hall

Dear Santa,
How are you and Mrs. Claus? You are very nice, I bet. I want a doll named Baby Heather. I want a baby brother. I know you can't bring me a brother.
Love,
Karen

Dear Santa,
How is Mrs. Santa? How is Rudolph and how are you? For Christmas I want a Jem doll

Dear Santa,
How is Mrs. Claus? How is Rudolph? Is he ready for Christmas? How is Mrs. Claus? Santa, my brother wants a bike for Christmas. Santa, I want a Bigfoot that has cars that smash.
Love,
Neal Hall

Dear Santa,
How are you and Mrs. Claus? You are very nice, I bet. I want a doll named Baby Heather. I want a baby brother. I know you can't bring me a brother.
Love,
Karen

Dear Santa,
How is Mrs. Santa? How is Rudolph and how are you? For Christmas I want a Jem doll

Dear Santa,
How is Mrs. Santa? How is Rudolph and how are you? For Christmas I want a Jem doll

and a pair of boots. My grandpa wants a watch.
Love,
Monica

Dear Santa,
How are you doing, and how is Mrs. Claus? And, How is Rudolph, too? I hope you have a great ride, too. I wish I could get Baby Heather and I wish for a kid sister. My big brother wished for a four wheeler, too.
Merry Christmas,
Heather Stanton

Dear Santa,
How are you and Mrs. Santa, and how is Rudolph doing? I live on 317 Turner. I do not know what I want. I will write a letter to you the night before Christmas. It will be on the table.
Love,
Brandon

Dear Santa,
How is Rudolph's red nose? Are you fixing your sled? Do you have lots of toys? Do you have a Christmas tree? I want a farm set. I want some fish. I want a go-cart.
Love,
Caleb

Dear Santa,
How are you doing? How is Rudolph? Do you like flying? I would like a Hot Look Doll and a Cabbage Patch Kid, and also the talking Jill. Merry Christmas.
Your friend,
Alesha Morris

Dear Santa,
I want a Turbo Hopper and a four wheeler, and a Ghostbuster set.
Love,
Johnny A.

Dear Santa,
I want a doll named My Child, and toys. Sometimes Santa is nice to me. I got to talk to Santa last night in the mall. I got a toy.
Love,

Shirlene

Dear Santa,
I want a Baby Heather, and a trampoline, and a Popple, and a My Child, and a real baby, and a puppy, and some skates.
Love,
Laura

Dear Santa,
I want a record player and a Walkman and a baby popple and

Dear Santa,
I want a record player and a Walkman and a baby popple and

Dear Santa,
I want a record player and a Walkman and a baby popple and

Dear Santa,
I want a record player and a Walkman and a baby popple and

Dear Santa,
I want a record player and a Walkman and a baby popple and

Dear Santa,
I want a record player and a Walkman and a baby popple and

I'd like a parakeet and a four wheeler and one more thing - a real puppy.
Love,
Jason

Dear Santa,
I want a Popple and a trampoline and a baby Heather and a bike. Mama wants a washing machine. Donnie wants a bike.
Love,
Norma

THE JOYS OF CHRISTMAS



May Christmas bring
friends to your fireside and
peace to your home. In
the glow of your friendship
we extend sincere thanks.

We appreciate our buyers and consignments, too

**Tom Flowers
& the staff**

Farwell Public Auto Auction
481-9400

Praised Be He.



Wishing you the special gifts of Christmas
... joy, peace and love.

**Oppliger
Land & Cattle Co.**
482-3361

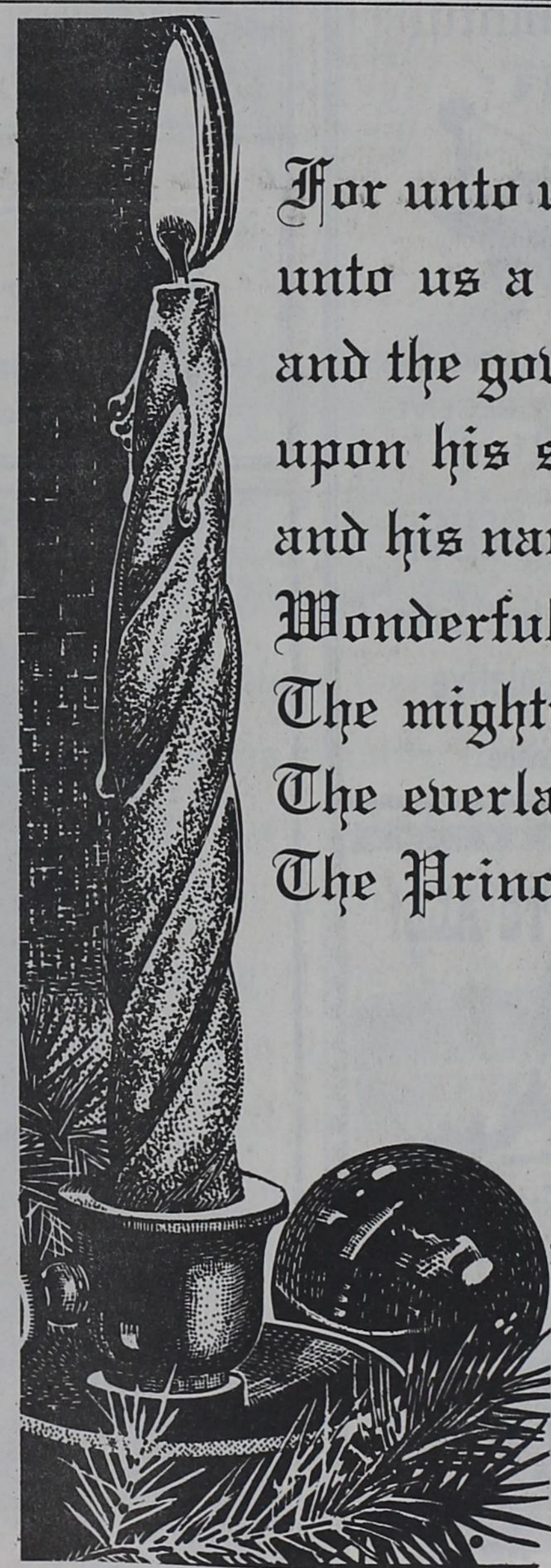

For unto us a child is born,
unto us a son is given:
and the government shall be
upon his shoulder:
and his name shall be called
Wonderful, Counsellor,
The mighty God,
The everlasting Father,
The Prince of Peace.
ISAIAH 9:6

In the spirit of
the Season we wish
you true happiness.
Merry Christmas
to our many friends!

**Farmers
Cooperative
Elevator**



Muleshoe Clay's Corner Enochs

A Joyous Christmas



Sing Hallelujah as all
herald the birth of The
Prince of Peace. We rejoice
with you and say thanks.

Jack, Rubie & Martha

SUMMIT SAVINGS ASSOCIATION

P.O. Box 732 Farwell, Texas 79325 Phone 481-3353

Member FSLIC

Miss Aragon wants a 1988 Mustang GT

Dear Santa,
I want a basketball and a skateboard. And Miss Aragon wants a 1988 Mustang GT. And I want a scooter and a play car. Merry Christmas.
Love,
Jesse

Dear Santa,
I want a tape recorder and a Baby Heather, and I want a real baby and a four-wheeler. I want a parakeet and I want a radio and a scooter and a wild Puffalump.
Love,
Amanda

Dear Santa,
I want some toys. I want a radio. I want a scooter. This is for Miss Aragon. She wants a 1988 GT Mustang. I want a Turbo-Hopper, and I want a skateboard. I want some Sonic Rangers. I want a sports watch.
Love,
Mel

Dear Santa,
I want a skate board, a Turbo-Hopper, a tape recorder, a wild Puffalump, some Ghostbusters, a 1988 Mustang GT, and Miss Aragon wants one, too. I want a stereo, a mask, a chemistry set, GI Joe, Sonic Rangers.
Drew Little

Dear Santa,
I want a real puppy and a skateboard and a grass hopper and I want a stereo and a real 1988 Mustang GT for Miss Aragon.
Love,
Seth

Dear Santa,
I want a scooter; I want a record player; I want a radio. Miss Aragon wants a 1988 Mustang GT. I want a four-wheeler. I want Turbo Hopper. I want a basketball.
Love,

Joel
Dear Santa,
I want a doll named Baby Heather. It is something I always wanted. I love Santa for everything he does for us on Christmas day. I am thankful for Santa Claus. He brings us all kinds of toys.
Love,
Jody Carey

Dear Santa,
This is my Christmas list. Here are the toys I want: a Baby Heather and a tape player and some roller skates and some new pants and a coat.
Love,
Angela

Dear Santa,
I want a Ghostbusters car, a four-wheeler, and a skateboard. And I want a tape recorder and a stereo, a Turbo Hopper, a Wild Puffalump, and a puppy. Miss Aragon wants a 1988 Mustang GT.
Love,
Travis Hall

Dear Santa,
I want a stereo and a 1988 Mustang GT, a radio, and a puppy.
Love,
Tom

Dear Santa,
I want a 1988 Mustang GT and Baby Heather and a My Child and a Real Baby and a Wild Puffalump.
Love,
Lee Ann

Dear Santa,
I wish I could have some roller skates and a 1988 Mustang GT and a chemistry set. Miss Aragon wishes she could have a Mustang GT.
Love,
Cindy

Dear Santa
I want some play makeup for Christmas and a 1988 Mustang GT for Miss Aragon, and a Baby Heather doll.
Love,
Yadira

Dear Santa,
I want a four-wheeler. My teacher wants a 1988 Mustang GT, and I want a stereo and I want a Turbo-Hopper, and I want a Ghost Busters. I am a boy.
Love,
Oliver Cardenas

Dear Santa Claus,
I want Lady Lovely Locks and Silky Mane.
Love,
Lindsey

Dear Santa,
I have been a good girl. I want a Barbie and the Rockers Doll and Julie the talking doll. And I also want the Heart to Heart Bears.
I love you,
Blanco Saenz

Dear Santa,
I've wanted a Barbie House for many days. Can you give me a

house, please?
Love,
Megan and Casey Rica
Dear Santa,
How do you feel? I would like a watch and a microscope.
Thank you,
Trevor Herington

Dear Santa,
I had been getting into trouble at school, but now I'm doing much better at school and at home. I keep my room clean. This year I would like to have Cricket's chair and a typewriter.
With Love,
Shawna

Dear Santa,
I want a stuffed animal and some skates. I also want for people who don't have a present to at least have one.
Josie Cortez
Grade 4 Lazbuddie

Dear Santa,
I want a real dog with food, and a toy bone and a real bone.
Adolfo Mata
Grade 4 Lazbuddie

I want a robot. I also want a b.b. gun. I want a motorcycle. I

also want a pair of boots and a wallet.
Love,
Jr. Lopez
Grade 4, Lazbuddie
Dear Santa,
Please bring me a puppy, a watch and a little toy car. I want a real horse. I also want a football and a baby calf.
Merry Christmas, Santa.
Love you,
Greg Cortez
Grade 3 Lazbuddie

Dear Santa,
I would like a Get In Shape, Girls and a pair of skates. I would also want a My Child and a makeup set. I would like a puppy.
Love,
Kayla Clark
Grade 3 Lazbuddie

Dear Santa,
I want a tv and a computer.

Then I want a Nintendo Entertainment System. Then I want the game called Duck Hunt.
Your friend,
Edward Terry
Grade 3 Lazbuddie
Dear Santa,
I want the Nintendo Game set, the Legend of Zelda, Ghostbuster Ecto 1, a mini tv, a dozen hotwheel cars, Captain Power. I would also like the movies Lady and the Tramp, Robin Hood, The Aristocats, Bambi, and Pinocchio.
Your friend,
Blake Mimms
Grade 3 Lazbuddie

Dear Santa,
I want some reins, and I want a real pistol. What I really want is a pair of chaps. I want a cotton stripper and spurs.
Love,
Tyler
Grade 3 Lazbuddie



Joy to the World
It's beginning to look like Christmas! May the Holidays bring you and yours every happiness.
High Plains Pest Control
Farwell 481-3451

NOEL

Let's all sing of the joy of Christmas!

CITY CLEANERS

707 Ave. A Farwell 481-3384

O Come All Ye Faithful

LET US OPEN OUR HEARTS DURING THIS MOST HOLY OCCASION, AS WE RECEIVE HIS MESSAGE OF LOVE AND FAITH.

LUCILLE PEUGH
Jones Pontiac Sales Representative

Thank you for your patronage

NOEL

Joy to the world, the Lord has come! May peace on earth become a reality at this holy time.

Kelly Green Seeds
"We Grow For You" Farwell

GREETINGS

Have A Beautiful Christmas

Steed - Todd
Funeral Home
Clovis

MERRY CHRISTMAS TO ALL!

Wishing you the best gift of the season — happiness at Christmas and always.

Weldon Rainey Janie Garcia
Marcy Pena Robert Woo
Parmer County office
Farmers Home Administration

Texico, Farwell teams tee off

Photos by
J.R. Ivins

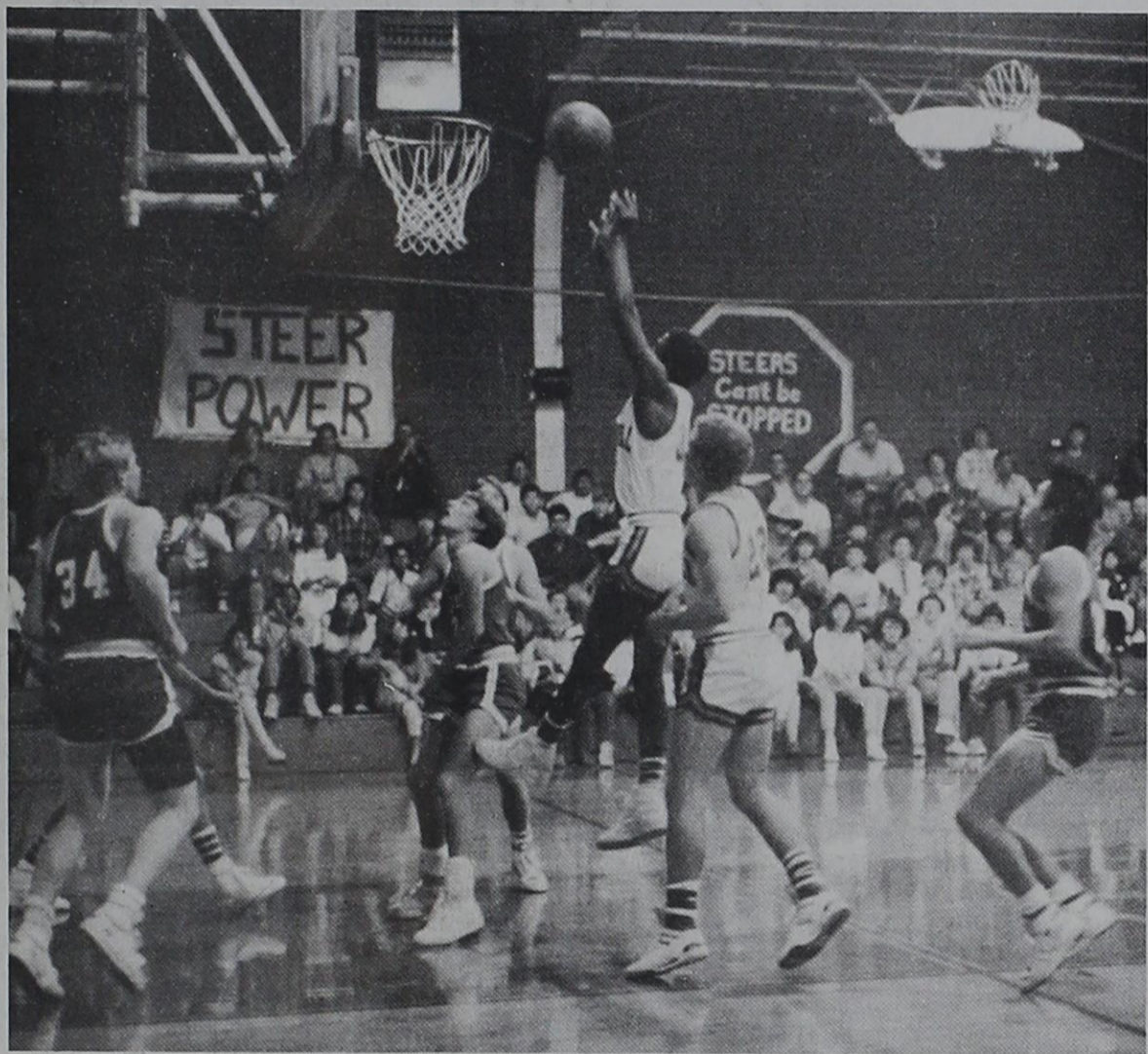
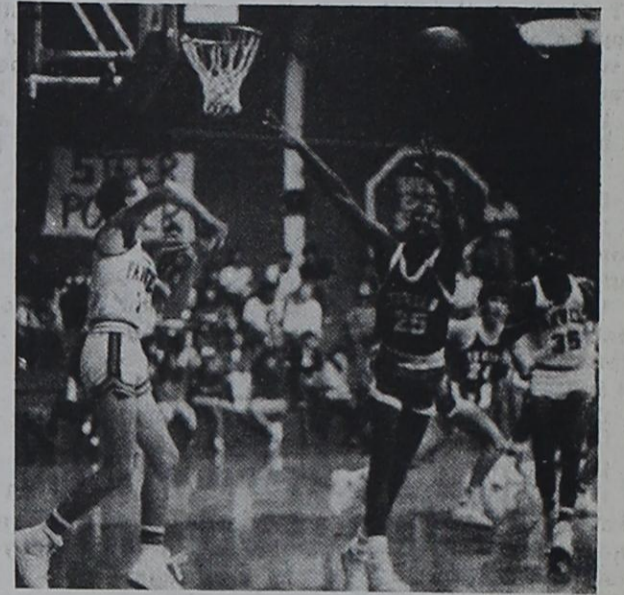
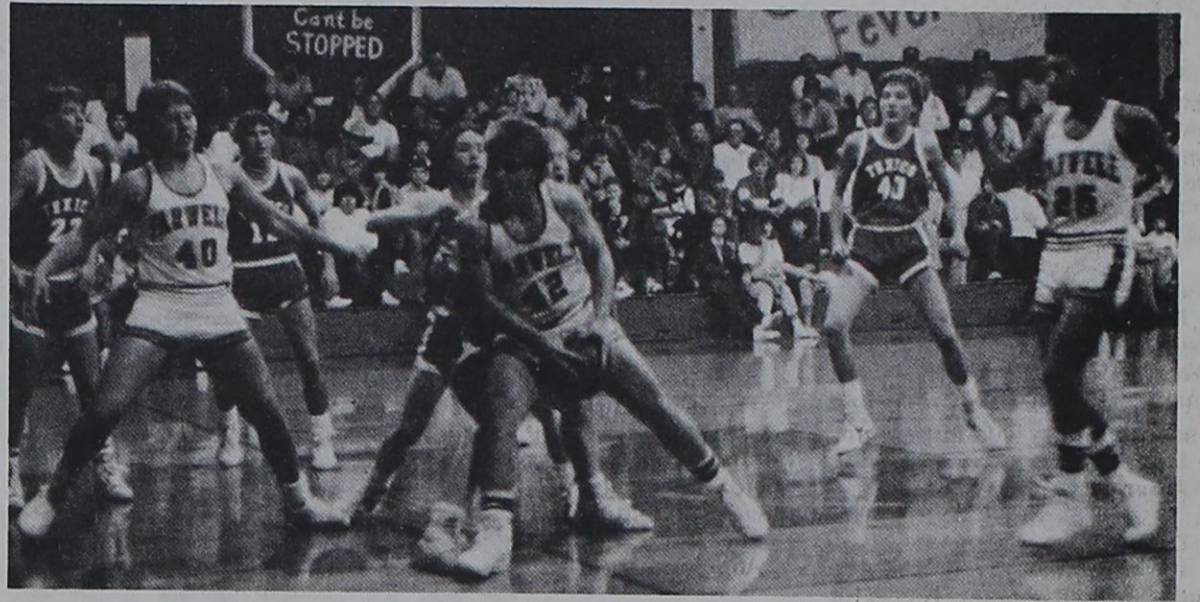

Behold...

People sometimes talk about the magic of Christmas. No one can deny that there is a special kind of atmosphere in the air about us, in the people we meet, in the events that take place during these days leading up to the festival of Christmas.

However, Christmas "magic" is not really the result of a magician waving his wand at just the right time and place, bringing thousands of colored lights and beautiful music into being. No, the true magic of Christmas is the result of a miracle - the miracle of God's grace and condescension displayed in the birth of his Son in our human world.

A marvelous description of that happening is found in Matthew 1:23, "Behold, a virgin shall conceive and bear a son, and his name shall be called Emmanuel (which means, God is with us)." That miracle which we celebrate again during this Advent/Christmas season brings about the magic of renewed hope, deep heart's peace and the certainty of personal relationship with Jesus Christ.

That's the true meaning and power of Christmas for each one of us. It may be yours and it may be mine through reaching out to trust him and to accept the great gift of Christmas, Jesus Christ our Lord.

May God bless you and all who are dear to you, now and through 1988.

Looking forward in Christ,
John Hoeger
President, Good Samaritan Society

Merry
Christmas

The Residents & Staff
Farwell Convalescent Center

And there were in the same country shepherds abiding in the field, keeping watch over their flock by night. And lo, the angel of the Lord came upon them and the glory of the Lord shone round about them: and they were sore afraid. And the angel said unto them, Fear not: for behold, I bring you good tidings of great joy, which shall be to all people. For unto you is born this day in the city of David a Saviour, which is Christ the Lord.

LUKE 2:8-11

Merry Christmas

Betty Jean Barb Mike & Judy

State Line Tribune
&
Texico-Farwell Printing

Glory to God in the Highest...

and on earth peace, good will toward men! That is the blessing we pray that the whole world will receive this Christmas. And to our many wonderful friends, we wish all the other blessings of the holiday season . . . the happiness of loved ones gathered together, the warmth of old friends' greetings, the pleasure of gifts piled beneath the tree, and the rejoicing of welcoming the Christ Child into your hearts on Christmas Eve . . . these are the special joys that we hope will come your way. Greetings from

SECURITY STATE BANK

Farwell, Texas

Member FDIC

R.W. Anderson - Pres.	Dolores Williams
Joe W. Jones - V.P.	Verna Davis
Marilyn Edwards - V.P.	Edith Chandler
Thomas Nichols - V.P.	Gloria Chavez
Dollie Porter - Cashier	Zelma Foster
Katherine White	Ouida Long
Janis Gast	

DIRECTORS

R.W. Anderson
 Caroline L. Anderson
 Homer Brumley
 Marilyn Edwards
 Virgol Joiner
 Joe W. Jones
 Thomas Nichols

